

# Product Catalogue

Tiger pneumatic hoisting, manual hoisting, clamping and winching ranges



### The home of ultimate quality, durable and safe products

Tiger Lifting manufacture and provide the full range of Tiger hoisting and winching products globally, including the Tiger Subsea Lifting range.

We have many close partnerships with successful distributors across the world and as a global innovator and provider we work constantly with customers and key suppliers to continually develop our products and product range.

We aim to set the highest standards in manufacturing, service, product reliability and safety and to provide industry leading value to our customers and supply chain partners.

Our hoisting range includes pneumatic air hoists, chain blocks and lever hoists, trolleys and combination units. We offer a wide range of winches for a variety of applications. Our expanding clamp range includes a variety of beam clamps, plate clamps and lifting clamps. We also offer spark proof, corrosion resistant and bespoke OEM products for special applications.



### Global track record and enviable reputation

We have manufactured the Tiger brand of manual lifting products for over 60 years and have a proven track record and an enviable reputation for supplying high quality, safe, stable products into a varied cross-section of demanding industries throughout the world.

We employ over 100 people across our distribution centres located in Europe, North America and South East Asia, our manufacturing plant based in Taiwan and our various sales offices in different countries.

Our range includes unique, patented designs and our products meet or exceed all relevant international standards, serving all spheres of global industry.

As the manufacturer of our hoisting and winching products, we hold complete technical files to provide full back-up and reassurance on our products' performance and to ensure that advice for our equipment is readily available. We have a wealth of technical expertise to give our customers full product support.

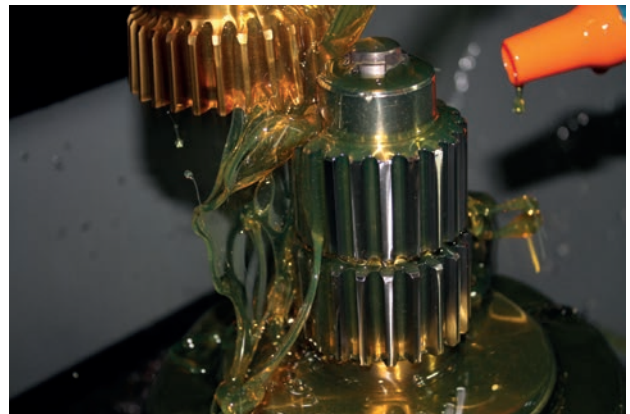



## A brand to rely on

Robust and reliable are phrases synonymous with Tiger Products. They must be, and are, of the highest quality in order to meet the lifting requirements specified by our customers and to operate effectively in the extremely harsh environmental conditions our clients often place them in.

## Innovation and client centric focus

Here at Tiger we take great pride in our innovative and client driven engineering background. With over 60 years of professional manufacturing experience, Tiger's commitment to innovation and customer satisfaction mean we will continue to develop our products - and ultimately solutions - for what can be complex scenarios, by communicating and working closely with our customers.

There are many examples of our innovation, improvements and response to client requirements. For example we have a patented pawl design in our professional and specialist ranges of manual lifting equipment which ensure the brake is still fully functional and the load is sustained without damage to the mechanism, even in the event of a pawl spring failure. Our patented "EZ Check" hook feature allows operators and inspection engineers to easily check to see if the hoist has been previously overloaded or shock loaded by simply measuring between the triangle of pop marks forged on the hook.

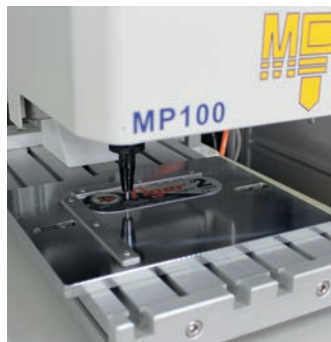
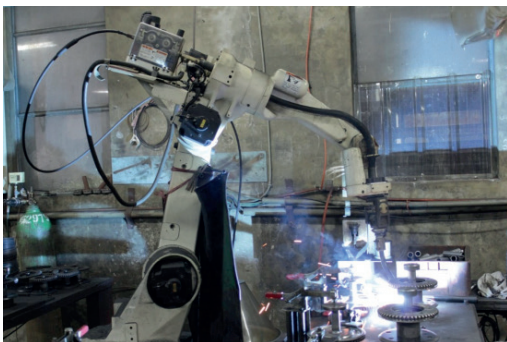

## Bespoke project work

We have the facilities, capacity and motivation to not only customise items from our own product collection, but to also create something completely different working to a client's own brief. We often provide bespoke products for special applications, and are committed to meeting the unique needs and expectations of our customers. Recent examples are 20t ROV chain blocks complete with ROV hooks and a 30t ultra low head room combination trolley and chain block with load cell shackle to meet specific project dimensions.

## 3D product drawings

We can provide 3D drawings of our products for project planning.

## Expanding range

We continually increase our range to include products our customers ask for. All products we include are of the highest quality. We aim to offer the best possible selection, service, quality and value without compromising our brand and values.

## Spares

Our products are exceptionally engineered, resilient and hard wearing and our clients' ability to service and maintain them is a crucial part of their getting best life-time value from them.

As the original manufacturer we only supply original Tiger replacement parts - all designed to our high engineering standards securing optimum performance and lifespan efficiencies.

Our full range of spares is available from stock so we can remain responsive to your requirements.

**Robust and reliable products, constant innovation and patented designs ensure Tiger meets your lifting requirements. We are perfectly positioned to provide best-in-class products to our global customer base.**

**Our innovation, your safety.**



# RiConnect and digitalisation



## RiConnect Connect to Safety

### RiConnect

RiConnect is an asset management tool which is controlled through cloud-based software. RiConnect provides not just a solution for asset management but also a platform for efficient and accurate information transaction between different parties along the supply chain, including product manufacturers, asset owners, and inspection service providers. It helps to maximize the utilization of assets, and optimise asset maintenance and inspection plans, while fulfilling the needs of all the stakeholders in the process.

### Supra digital chips

Sustainability is increasingly important. Quality, reliability and serviceability of products, increasing product life cycles, is essential. Making use of digitalisation technologies like RFID (which is within the SupraTag) to digitalise inspection management systems and efficiently manage inventory will become important. Having instructions, certification, inspection information and checklists available digitally helps companies manage their environmental impact and reduces time for equipment to be put into service making for more efficient operations.

There are a range of Supra digital chips, tags and readers suitable for most Tiger products. Please contact our sales team for more information on the suitable RFID for a specific product.

### Universal tags



### Atex tags



### Readers





# Sustainability and traceability

## Sustainability

We're keen to talk about sustainability whenever we can and believe that anything that helps the many parties in the lifting equipment supply chain become more sustainable and efficient is a very positive step.

Our products are 100% recyclable and when they do eventually reach the end of their product life span, we work with our customers to recycle products, and on fleet replacement. Life-cycle engineering has always been important to Tiger Lifting and we have been focused on sustainability-oriented product development activities for many years. This involves the raw materials we use, our manufacturing and production processes, transportation, the utilisation and re-utilisation of our products and then their ultimate disposal and recyclability.

We work with well-established supply chains who are all working on their own sustainability agendas and as a global group, Tiger are all focused on sustainability and are constantly looking at ways to reduce their carbon footprint. This includes initiatives like using highly energy efficient heating systems and construction practices in our buildings, reusing and recycling what we can, electric car options for company cars, and using closer local ports for shipping.



## Traceability

A forged in batch number on all Tiger products is used to record the material grade and origin.

With our product information and certification uploaded to the RiConnect platform, and scanning of product digital chips using near-field communication (NFC) technology, product information relating to usability and traceability of a product is readily available. The fact that you can access this information using the RiConnect smart phone APP and a smart phone (with NFC capability) makes this very accessible.



# Certification and third party verification

We have a range of certification covering our products and operations.

## Customer third party verification and audits

We often accommodate independent verification of our products and test facilities to meet various global and regional requirements and welcome customer audits of our operations. We have worked with many of the International Association of Classification Societies (IACS) such as Lloyd's Register, DNV GL, Bureau Veritas (BV) and American Bureau of Shipping (ABS), verifying compliance of our products with published standards.

## Multi-immersion testing

After successfully completing a series of independent third party verification and testing programmes to established international standards, including 3rd party multi-immersion tests at ORE Catapult in the UK, we are very pleased to be able to state that the SS19 and SS20 range of hoists are fit for use in multi-immersion applications.

The above statement is effective providing the timescales, pre-use testing, maintenance and service requirements as detailed in Tiger document Multi-immersion Instruction Document 201603 are strictly adhered to.



## Spark resistant products

Our spark resistant products are third party verified to the European Union Directive 2014/34/EU, the Machinery Directive 2006/42/EC and IECEx and have Atex marking: Ex II 2 GD c IIC T4 IIIC T135°C. Suitable for gas and dust hazardous areas: Zone 1 & 2 (gas) and Zone 21 & 22 (dust).



## Tiger chain blocks & lever hoists achieve DNV GL third party verification

Tiger chain blocks and lever hoists (with overload limiters) have been verification tested according to NORSOK R-002. Testing was carried out by DNV GL AS at the company's corrosion and materials technology laboratory in Bergen, Norway. NORSOK R-002 is one of the most prescriptive standards for lifting appliances and lifting accessories, going further than most standards to ensure complete safety in the oil and gas industry. It targets key known failure modes that can be apparent in mass produced branded products.

The scope included:

- Overload protection load tests to maximum permissible load
- Independent testing of the two independent brake mechanisms
- Various load and functional tests
- Tests of chain end connection to minimum chain breaking load

To meet the requirements for extensive corrosion protection (section 5.24) we were able to provide all the necessary manufacturing documentation to achieve verification against this critical part of the standard.

About DNV GL

Driven by its purpose of safeguarding life, property and the environment, DNV GL enables organisations to advance the safety and sustainability of their business. They provide classification and technical assurance along with software and independent expert advisory services to the maritime, oil and gas, and energy industries. They also provide certification services to customers across a wide range of industries. Operating in more than 100 countries, their 16,000 professionals are dedicated to helping their customers make the world safer, smarter and greener.



## PNEUMATIC HOISTING

Our range of pneumatic hoisting equipment is designed for, and proven in, many industries including mining, shipyards, offshore construction and power stations. They are also used for industrial and general engineering applications such as automotive plants, foundries, and heat treatment plants. Our manufacturing facility is ISO9001 certified.



- Air hoists ..... 8
- Low headroom air trolley and hoist ..... 16
- Air trolleys and air winch ..... 17

PNEUMATIC HOISTING

## MANUAL HOISTING

Our range of manual hoisting equipment is renowned as some of the best in the industry and is the equipment of choice for many quality and safety driven organisations. Features such as the Quad Cam pawls, centrifugal torsion brake, "EZ Check" hooks, cross-hauling capabilities and load limiters ensure that your safety is never compromised.



- Chain blocks and lever hoists overview ..... 18
- Adaptable chain blocks and lever hoists ..... 20
- Spark resistant chain blocks and lever hoists ..... 22
- Lever hoists ..... 24
- Multi immersion ..... 29
- Chain blocks ..... 30
- ROV compatible chain block ..... 34
- Power PRO hoist with load limiter ..... 38
- Combination chain block and trolleys ..... 40
- Trolleys ..... 44
- Beam anchor ..... 50
- Wire rope puller ..... 52
- Webbing puller ..... 54
- Entertainment rigging ..... 55

MANUAL HOISTING

## CLAMPING

Tiger have a range of clamps for different applications, including the BCU universal clamp designed not only for vertical use, but also for side load applications, where conventional clamps are not suitable. The TVC clamp, used for lifting and handling of pre-assembled reinforcing round or irregular shaped steel bars and the CSS safety screw cam clamp with double eye anchor points and safety torque feature.



- Universal beam clamp BCU ..... 56
- Bulb flat bar anchor clamp BCB ..... 57
- Fixed jaw heavy duty beam clamp with shackle BCF ..... 58
- Adjustable beam clamp with shackle BCS ..... 60
- Adjustable beam clamp BC ..... 61
- Drum lifting clamp DLC ..... 61
- Safety screw cam clamp CSS ..... 62
- Screw cam clamp SCC ..... 63
- Vertical lifting clamp SVC-E ..... 63
- Vertical lifting clamp TVC ..... 64
- Screw cam clamp CSC ..... 64
- Drum lifting clamp CDL ..... 64
- Vertical drum clamp CDV ..... 64
- Rail clamp CRT ..... 64
- Adjustable angle beam clamp BCA ..... 66

CLAMPING

## WINCHING

Tiger have a wide range of winches used in many industries throughout the world. They are of superior construction and built to last. The high quality powder coated finish gives maximum corrosion resistance. They are rugged and durable to withstand the harsh conditions they are used in. Tiger are manufacturers of the original brake hand winch.

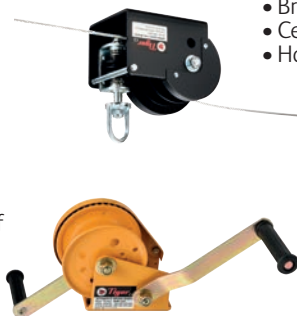

- Industrial winch ..... 67
- Brake hand winch ..... 68
- Ceiling mounted winches ..... 70
- Hand winches ..... 72

WINCHING

## USEFUL INFORMATION



- Product guidelines ..... 74
- Quality statement ..... 74
- Product support ..... 74
- Product documentation ..... 74
- Returns policy ..... 75
- Copyright ..... 75
- Terms and conditions ..... 75
- Disclaimer ..... 75

USEFUL INFORMATION



# Air hoists



Tiger industrial air hoists are designed for, and proven in, many industries including mining, shipyards, offshore construction and power stations. They are also used for industrial and general engineering applications such as automotive plants, foundries, and heat treatment plants. The hoists operate at air pressures of between 4 and 6 bar. They comply with the requirements of ASME B30.16 and EN14492-2. Our manufacturing facility is ISO9001 certified.

- Range - 250kg to 60 tonne
- Reliable, fast, efficient, quiet and lightweight
- Greater than 5:1 factor of safety
- Suitable for Fleeting/Oblique pulling
- Certified for ATEX Category 3 as standard. Category 2 available on request

## TAHS

## TAH21

## TAH33

## TAH52

## TAH250

## TAH-M



250kg, 500kg,  
1t & 2t

1.5t, 2t & 3t

3t, 6t & 10t

5t, 10t, 16t & 20t

25t, 30t, 37.5t,  
40, 50 & 60t

2t/2t, 3t/3t &  
3t/6t

### Pendant control

Our air hoists are supplied with either aluminium hard anodised controls which offer excellent corrosion protection or our Nickel plated SG iron option (for higher impact resistance combined with greater tensile strength and superior corrosion protection). Twist grip pendants are available as an option. Our new dual control pendant will operate two hoists with one pendant control. We also have a new remote control option available.



Aluminium hard  
anodised pendant



Nickel plated SG iron  
pendant



Optional twist grip pendant



New dual hoist pendant



New

New remote control

**Load limiter**

Integral differential pressure load limiting valve automatically prevents the operator lifting a load of more than 125 % of the working load limit. Load limiter is 100 % repeatable at all working pressures and does not wear or generate damaging heat.

**Emergency stop**

Pendant control hoists are supplied with a mains emergency stop valve. This shuts off the main air supply to the hoist when activated.

**Temperature Range**

Ambient temperature range -20°C to +70°C (for temperatures outside of this range please contact us for details).

**Precise control**

Accurate and precise positioning of loads is standard for both toggle and pendant control models.

**Fail safe disc brake**

Non-asbestos self-adjusting disc brake is applied automatically when the air supply to the hoist is shut off. The brake is self-adjusting for the life of the brake and can hold more than 125 % of the working load limit.

**Fleeting, cross hauling or oblique pulling**

This type of application is when the load deviates from the vertical position with a force acting directly between load hook and suspension point. Our air hoists can be used for fleeting and oblique pulling operations with no de-rating of the hoist. Cross hauling can be done with a single hoist, two hoists operated independently or with two hoists operated off one dual hoist pendant control.

**Integral silencer**

The exhaust air silencer is built into the hoist gearbox housing and limits the noise level to below 85dB(A).

**Load chain**

Grade 8 load chain ensures stringent high-speed duty cycles can be met. The load chain is in accordance with the requirements of EN818-7 Appendix B.

**Vane motor**

Assisted vane lifting ensures maximum starting torque when starting under load.

**Sealed gearbox**

The sealed planetary gearbox ensures that the most stringent duty cycles can be met. The gears are heat treated and mounted on high strength, low friction bearings.

**Ease of maintenance**

The modular design of the hoist allows easy access to internal components such as the motor, gearbox, brake and load limiter. Common parts are used throughout the range.

**Optional chain carrier**

Designed to carry and hold the length of load chain required for the operation, our stainless steel chain bucket is available in different size options. These chain carriers prevent loose chain from getting snagged during lifting or lowering operations and protect any loose chain during transit to and from the operational site.



**ATEX**

Manufactured in accordance with ATEX Directive 2014/34/EU and Machinery Directive 2006/42/EC and suitable for ATEX Category 3 – normal safety. Our products are assigned as follows: ATEX marking: : Ex II 3 GD c IIB T4 IIIB T135°C. Suitable for gas and dust hazardous areas: Zone 2 (gas) and Zone 22 (dust).

Ex II 3 GD c IIB T4 IIIB T135°C

II	3	GD	c	IIB	T4	IIIB	T135°C	
							<b>T135°C</b>	Dust Temperature Class: Maximum external surface temperature 135°C
							<b>IIIB</b>	Groups of Dust: Protected for group IIIC which includes groups IIIA
							<b>T4</b>	Gas Temperature Class: Maximum external surface temperature 135°C
							<b>IIB</b>	Gas Explosion Group: Protected for group IIB which includes group IIA
							<b>c</b>	Protection type: Design safety
							<b>GD</b>	Ex Atmosphere: Gas and Dust
							<b>3</b>	Category: Normal Safety
							<b>II</b>	Equipment Group: surface industries



Also available for ATEX Category 2 – high safety – please contact us for more information.

TAHS Range - 250kg, 500kg, 1.0, 2.0 tonne technical data (at 6 bar)

	AH-002	AH-005	AH-010	AH-020
Lifting Capacity (tonne)	0.25	0.5	1.0	2.0
Falls of Chain	1	1	1	2
Chain Size (mm)	7.1 x 21.2	7.1 x 21.2	7.1 x 21.2	7.1 x 21.2
Total Weight (kg)*	25.0	25.0	25.0	32.8
Full Load Lifting Speed (m/min)	22.5	15.0	7.5	3.8
No Load Lifting Speed (m/min)	32.0	29.5	16.0	8.0
Full Load Lowering Speed (m/min)	31.0	36.0	20.4	10.2
No Load Lowering Speed (m/min)	25.0	23.0	13.0	6.5
Air Consumption (m <sup>3</sup> /min)	2.1	2.1	2.1	2.1
Air Connection	G 1/2	G 1/2	G 1/2	G 1/2
Supply Hose (Inside ø) (mm)	16.0	16.0	16.0	16.0
Sound Level (dB(A))	76	76	76	76
Dimensions (mm): A	312	312	312	312
B	216	216	216	216
C	135	135	135	135
D	85	85	85	85
E	196	196	196	196
F (Min)	370	370	370	370
G (Min)	420	420	420	-
H (Min)	-	-	-	495

\* Weight of TAHS model includes 3m lift, 2m toggle control. For longer lifts add 1.1kg for the AH-002, AH-005 and AH-010 models and 2.2kg for AH-020 per metre of lift. For pendant control add 0.8kg.



250kg TAHS with toggle control (AH-002T)

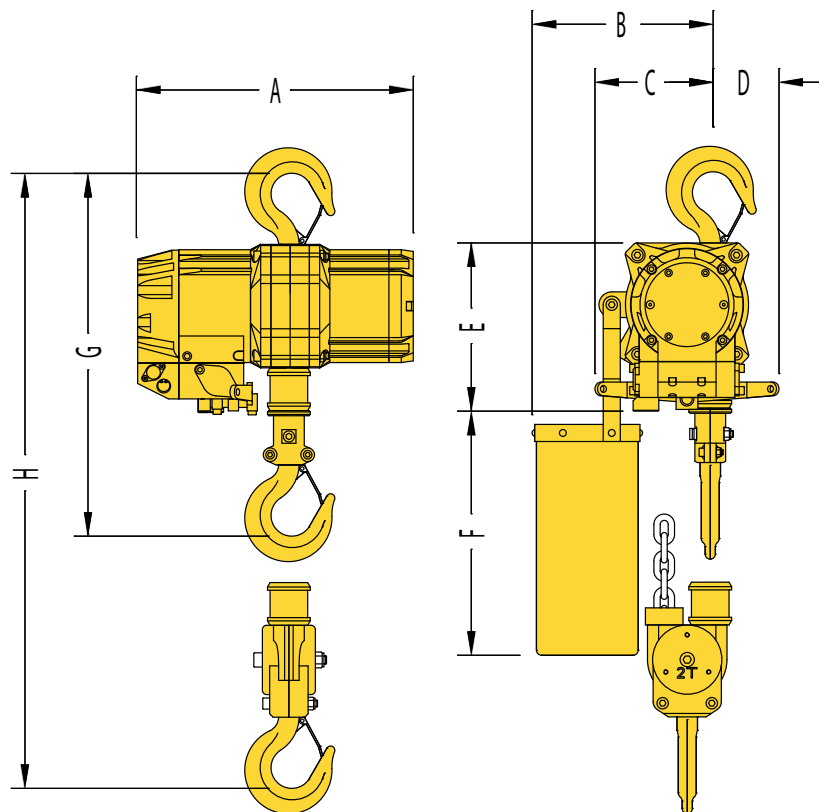

250kg-2t



**TAH21 Range - 1.5, 2.0, 3.0 tonne technical data**

	AH-015	AH-021	AH-032
Lifting Capacity (tonne)	1.5	2.0	3.0
Falls of Chain	1	1	2
Chain Size (mm)	10 x 28	10 x 28	10 x 28
Total Weight (kg)*	55	55	67
Full Load Lifting Speed (m/min) @ 6 bar	6.2	5.3	3.1
Full Load lifting Speed (m/min) @ 4 bar	4.2	3.0	2.1
No Load Lifting Speed (m/min) @ 6 bar	8.7	8.7	4.3
Full Load Lowering Speed (m/min) @ 6 bar	8.6	9.0	4.3
No Load Lowering Speed (m/min) @ 6 bar	7.5	7.5	3.7
Air Consumption (m <sup>3</sup> /min) @ 6 bar	2.6	2.6	2.6
Air Consumption (m <sup>3</sup> /min) @ 4 bar	1.7	1.7	1.7
Air Connection	G 3/4	G 3/4	G 3/4
Supply Hose (Inside ø) (mm)	19	19	19
Sound Level (dB(A)) Full Load Lifting @ 6 bar	81	81	81
Full Load Lowering @ 6 bar	83	83	83
Dimensions (mm): A	382	382	382
B	250	250	250
C	184	184	184
D	66	66	66
E	213	213	213
F (Min)	515	515	-
G (Min)	-	-	610



2t TAH21 with E-stop pendant control (AH-021P)

\* Weight of TAH21 model includes 3m lift, 2m toggle. For longer lifts add 2.2kg per metre of lift for the AH-015 and AH-021 and 4.4kg for the AH-032 per metre of lift. For pendant control add 0.4kg, for E/Stop pendant add 2.1kg.

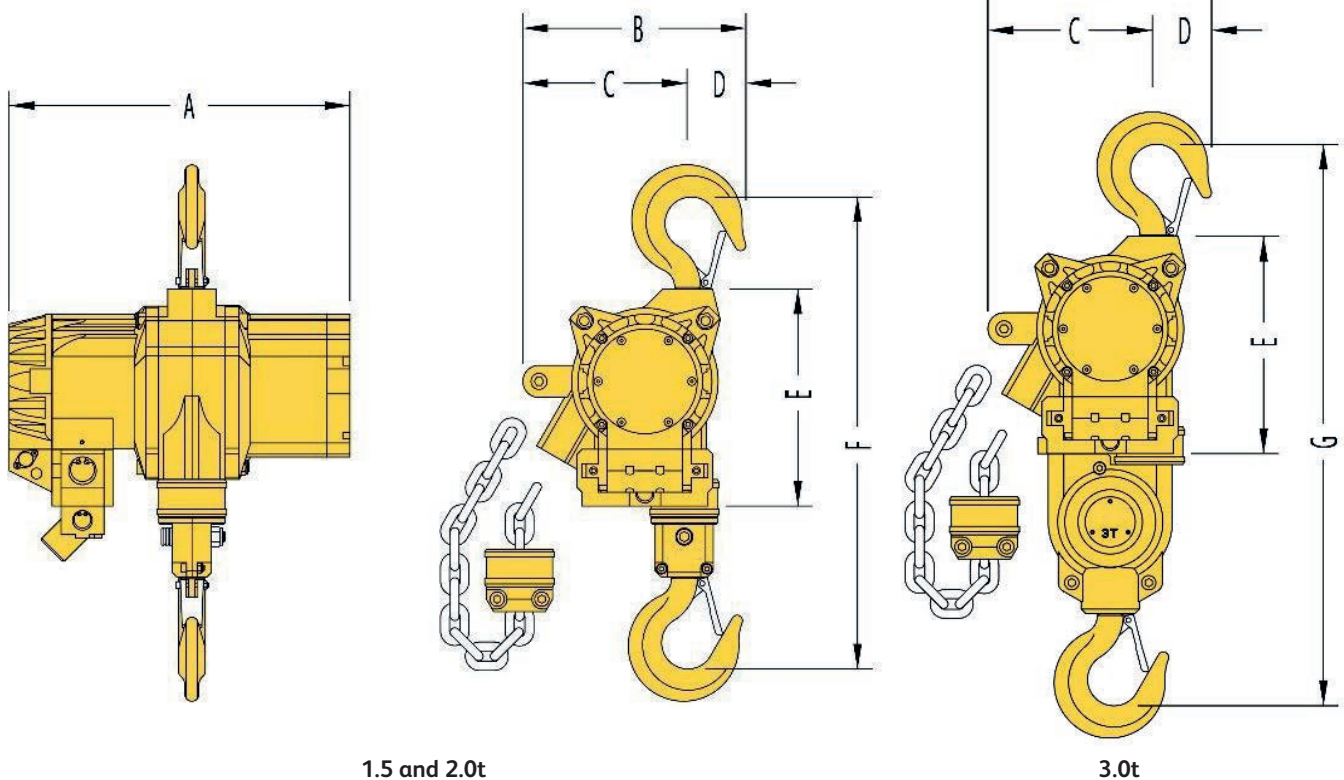

1.5 and 2.0t

3.0t

**TAH33 Range - 3.0, 6.0, 10.0 tonne technical data**

	AH-030	AH-060	AH-103
Lifting Capacity (tonne)	3.0	6.0	10.0
Falls of Chain	1	2	3
Chain Size (mm)	13 x 36	13 x 36	13 x 36
Total Weight (kg)*	76.5	99.5	139.5
Full Load Lifting Speed (m/min)@ 6 bar	5.3	2.6	1.6
Full Load Lifting Speed (m/min) @ 4 bar	3.8	1.9	1.1
No Load Lifting Speed (m/min) @ 6 bar	7.5	3.7	2.4
Full Load Lowering Speed (m/min) @ 6 bar	8.3	4.1	2.6
No Load Lowering Speed (m/min) @ 6 bar	6.8	3.4	2.2
Air Consumption (m <sup>3</sup> /min) @ 6 bar	4.0	4.0	4.0
Air Consumption (m <sup>3</sup> /min) @ 4 bar	2.6	2.6	2.6
Air Connection	G 3/4	G 3/4	G 3/4
Supply Hose (Inside ø) (mm)	25	25	25
Sound Level (dB (A)):			
Full Load Lifting @ 6 bar	81	81	81
Full Load Lowering @ 6 bar	83	83	83
Dimensions (mm): A	466	466	466
B	254	223	366
C	185	137	243
D	N/A	86	123
E	N/A	259	315
F (Min)	538	N/A	N/A
G (Min)	N/A	630	786



**3t TAH33 with E-stop pendant control (AH-030P)**

\* Weight of TAH33 model includes 3m lift, 2m toggle. For longer lifts add 3.8kg per metre of lift for the AH-030, 7.6kg for AH-060 and 11.4kg for the AH-103 per metre of lift. For pendant control add 0.8kg



**3t**



**6t**

**TAH52 Range - 5.0, 10.0, 16.0, 20.0 tonne technical data**

	AH-050	AH-102	AH-160	AH-200
Lifting Capacity (tonne)	5.0	10.0	16.0	20.0
Falls of Chain	1	2	3	4
Chain Size (mm)	16 x 45	16 x 45	16 x 45	16 x 45
Total Weight (kg)*	106	152	245	288
Full Load Lifting Speed (m/min)@ 6 bar	3.0	1.5	0.9	0.7
Full Load Lifting Speed (m/min) @ 4 bar	1.9	0.9	0.6	0.4
No Load Lifting Speed (m/min) @ 6 bar	4.0	2.0	1.1	0.9
Full Load Lowering Speed (m/min) @ 6 bar	4.4	2.2	1.3	1.0
No Load Lowering Speed (m/min) @ 6 bar	3.3	1.7	1.0	0.8
Air Consumption (m <sup>3</sup> /min) @ 6 bar	4.0	4.0	4.0	4.0
Air Consumption (m <sup>3</sup> /min) @ 4 bar	2.6	2.6	2.6	2.6
Air Connection	G 3/4	G 3/4	G 3/4	G 3/4
Supply Hose (Inside ø) (mm)	25	25	25	25
Sound Level (dB(A)):				
Full Load Lifting @ 6 bar	82	82	82	82
Full Load Lowering @ 6 bar	83	83	83	83
Dimensions (mm): A	503	503	616	616
B	300	270	290	280
C	230	170	180	165
D	N/A	100	110	115
E	N/A	286	325	325
F (Min)	600	N/A	N/A	N/A
G (Min)	N/A	790	905	920



**16t TAH52 with toggle control (AH-160T)**

**5t TAH52 with remote control (AH-050R)**

\* Weight of TAH52 model includes 3m lift, 2m toggle control. For longer lifts add 5.7kg for the AH-050, 11.4kg for the AH-102, 17.1kg for the AH-160 and 22.8kg for the AH-200 per metre of lift. For pendant control add 0.8kg

Due to our policy of continual product development, dimensions, weights and specifications may change without prior notice. Please check with your Tiger sales team when ordering.

Bespoke designs available on request- contact [info@tigerlifting.com](mailto:info@tigerlifting.com) for more information.

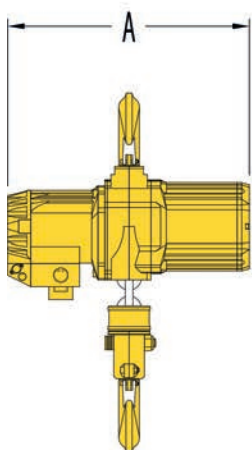

**5t**

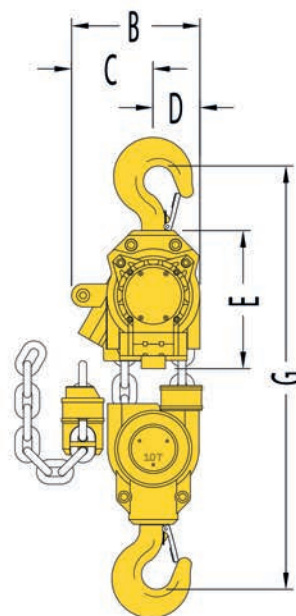
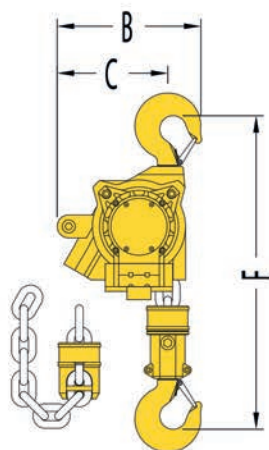

**10t**

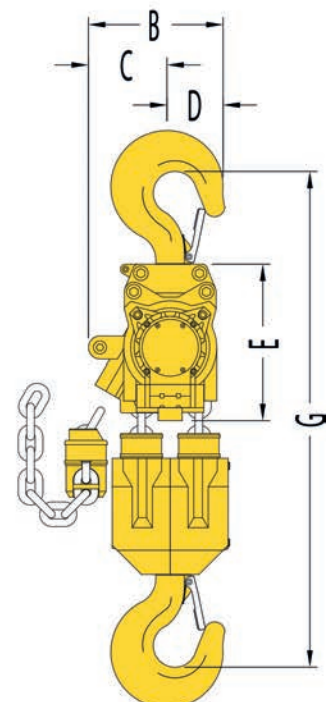

**16.0t/20.0t**



**TAH250 Range - 25.0, 30.0, 37.5, 40.0, 50.0, 60.0 tonne technical data**

	AH-250	AH-300	AH-375	AH-400	AH-500	AH-600
Lifting Capacity (tonne)	25.0	30.0	37.5	40.0	50.0	60.0
Falls of Chain	2	2	3	3	4	5
Chain Size (mm)	23.5 x 66	23.5 x 66	23.5 x 66	23.5 x 66	23.5 x 66	23.5 x 66
Total Weight (kg)*	585	585	885	885	985	985
Full Load Lifting Speed (m/min)@ 6 bar	1.4	1.2	0.9	0.8	0.7	0.6
Full Load Lifting Speed (m/min) @ 4 bar	0.9	0.8	0.6	0.5	0.45	0.4
No Load Lifting Speed (m/min) @ 6 bar	2.5	2.5	1.6	1.6	1.25	1.25
Full Load Lowering Speed (m/min) @ 6 bar	2.7	2.9	1.8	1.9	1.35	1.45
Air Consumption (m <sup>3</sup> /min) @ 6 bar	6.5	6.5	6.5	6.5	6.5	6.5
Air Consumption (m <sup>3</sup> /min) @ 4 bar	4.4	4.4	4.4	4.4	4.4	4.4
Air Connection	G1 1/2	G1 1/2	G1 1/2	G1 1/2	G1 1/2	G1 1/2
Supply Hose (Inside ø) (mm)	35	35	35	35	35	35
Sound Level (dB(A)):						
Full Load Lifting @ 6 bar	82	82	82	82	82	82
Full Load Lowering @ 6 bar	85	85	85	85	85	85
Dimensions (mm): A	762	762	937	937	937	937
B	422	422	450	450	450	450
C	277	277	266	266	266	266
D	145	145	184	184	184	184
E	605	605	630	630	630	630
F (Min)	1290	1290	1455	1455	1475	1475



**30t TAH250 with E-stop pendant control (AH-300)**

Due to our policy of continual product development, dimensions, weights and specifications may change without prior notice. Please check with your Tiger sales team when ordering.  
 Bespoke designs available on request- contact [info@tigerlifting.com](mailto:info@tigerlifting.com) for more information.

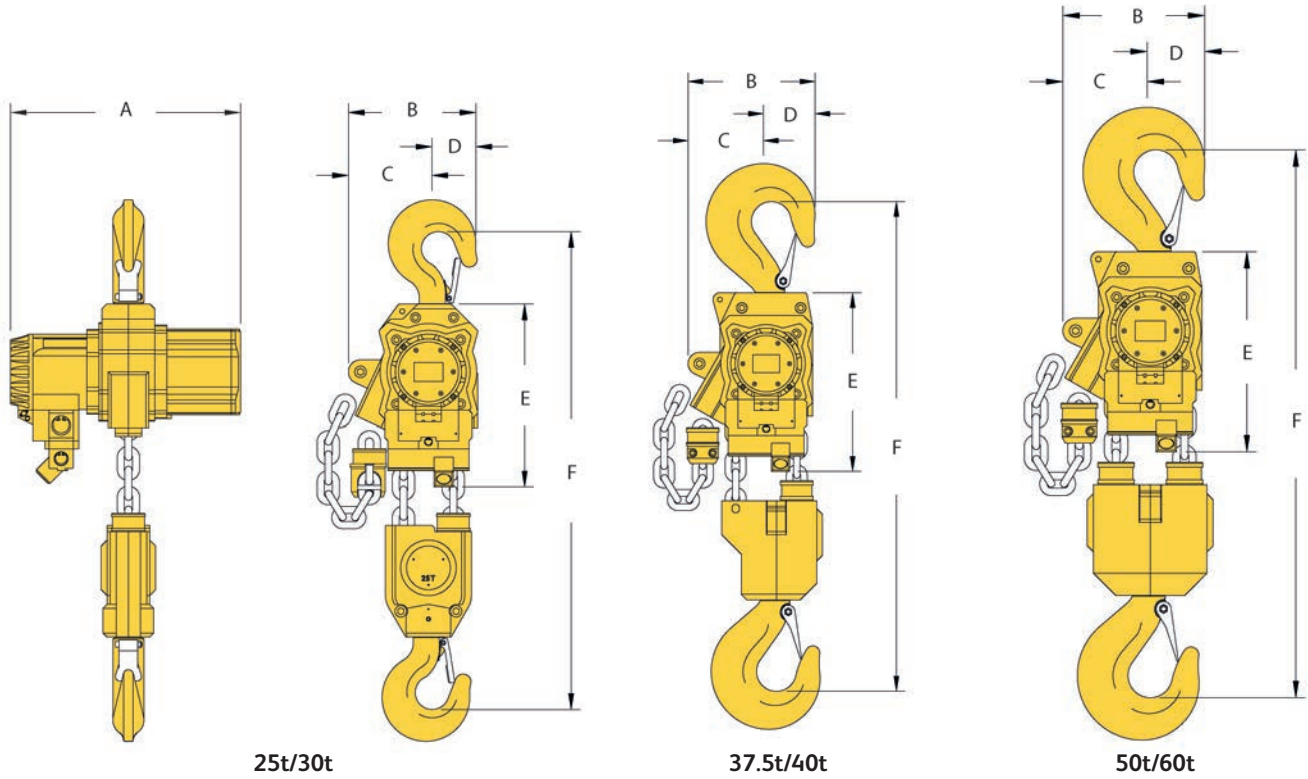

**TAH-M Range - TAH21M 2.0t/2.0t configuration, TAH33M 3.0t/3.0t and 3.0t/6.0t configurations technical data**

	AHM-021	AHM-030	AHM-063
Lifting Capacity (tonne)	2.0/2.0	3.0/3.0	3.0/6.0
Falls of Chain	1/1	1/1	1/2#
Chain Size (mm)	10 x 28	13 x 36	13 x 36
Total Weight (kg)*	66.0	82.0	102.0
Full Load Lifting Speed (m/min)@ 6 bar	4.7	4.9	4.9/2.4
Full Load Lifting Speed (m/min) @ 4 bar	2.6	3.2	3.2/1.6
No Load Lifting Speed (m/min) @ 6 bar	7.0	6.4	6.4/3.2
Full Load Lowering Speed (m/min) @ 6 bar	7.5	7.0	7.0/3.5
No Load Lowering Speed (m/min) @ 6 bar	5.9	5.4	5.4/2.7
Air Consumption (m <sup>3</sup> /min) @ 6 bar	2.6	4.0	4.0
Air Consumption (m <sup>3</sup> /min) @ 4 bar	1.7	2.6	2.6
Air Connection	G 3/4	G 3/4	G 3/4
Supply Hose (Inside ø) (mm)	19	25	25
Sound Level (dB(A)):	83	83	83
Dimensions (mm): A	382	466	466
B	192	215	215
C	96	108	130
D	-	-	85
E	345	345	345
F (Min)	537	548	599
G (Min)	-	-	689



**TAH33M 3.0t/6.0t configuration with twist grip pendant (AHM-063)**

\* Weight is for 3m HOL, E/Stop pendant control (2m) J-hooks

# An extra metre of chain will give 1m extra HOL on the 3t side and 0.5m extra HOL on the 6t (2 fall) side

Due to our policy of continual product development, dimensions, weights and specifications may change without prior notice. Please check with your Tiger sales team when ordering.

Bespoke designs available on request- contact [info@tigerlifting.com](mailto:info@tigerlifting.com) for more information.

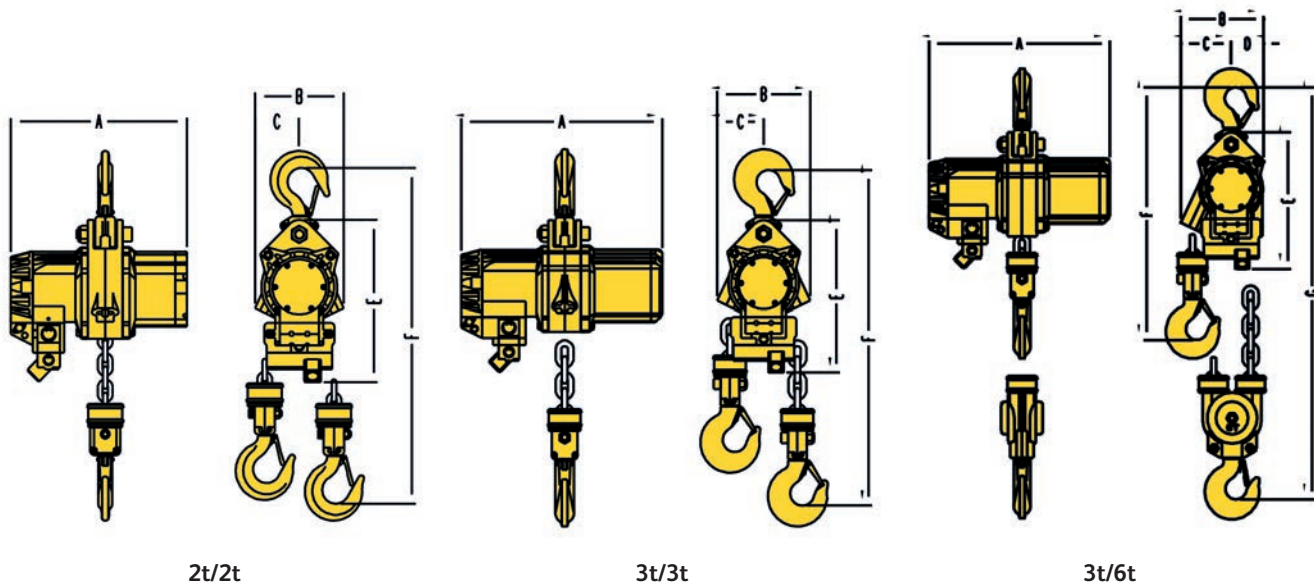

# Low headroom air trolley and hoist



ULT series hoists are designed specifically for mining, industrial and general engineering applications where headroom is extremely limited such as locomotive battery bays, pump chambers and underground workshops. They are available in geared and motorized traverse versions. The hoists operate at air pressures of between 4 and 6 bar and have a factor of safety in excess of 5 at the rated load. They comply with the requirements of SANS 1638, ASME B30.16 and EN14492-2. The manufacturing facility producing the hoists is ISO9001, ISO14001 & OHSAS18001 certified.

- Range - 2, 3, 4 & 6 tonne
- Ultra-low headroom, compact and versatile
- Available in geared and motorized versions
- Greater than 5:1 factor of safety
- Integrated load limiter



Bespoke designs available on request - contact [info@tigerlifting.com](mailto:info@tigerlifting.com) for more information.

	ULTA2200	ULTA3200	ULTA4200	ULTA6200
Lifting Capacity (tonne)	2.0	3.0	4.0	6.0
Falls of Chain	2	2	2	4
Chain Size (mm)	10 x 28	10 x 28	10 x 28	10 x 28
Total Weight (kg)*	230	235	235	265
Full Load Lifting Speed (m/min) @ 6 bar	5.3	4.8	3.6	2.4
Full Load Lifting Speed (m/min) @ 4 bar	3.2	3.0	2.3	1.5
Traverse Speed (m/min) @ 6 bar	28.0	28.0	28.0	27.0
Air Consumption (m <sup>3</sup> /min) @ 6 bar	2.6	4.0	4.0	4.0
Air Consumption (m <sup>3</sup> /min) @ 4 bar	1.7	2.6	2.6	2.6
Air Connection	G 3/4	G1	G1	G1
Supply Hose (Inside ø) (mm)	19	25	25	25
Sound Level (dB(A))	83	83	83	83
Minimum Headroom (mm)	260	265	265	234
Minimum Beam Curve Radius (mm)	3600	3600	3600	4200

Due to our policy of continual product development, dimensions, weights and specifications may change without prior notice. Please check with your Tiger sales team when ordering.

\* Weight includes 3m lift, 2m pendant control.  
 \* For longer lifts add 4.4 kg for the ULTA2200, ULTA3200, ULTA4200 and 8.8kg for the ULTA6200.

## Monorail hoists

10t, 16t and 20t monorail hoists now available - ask us for details.

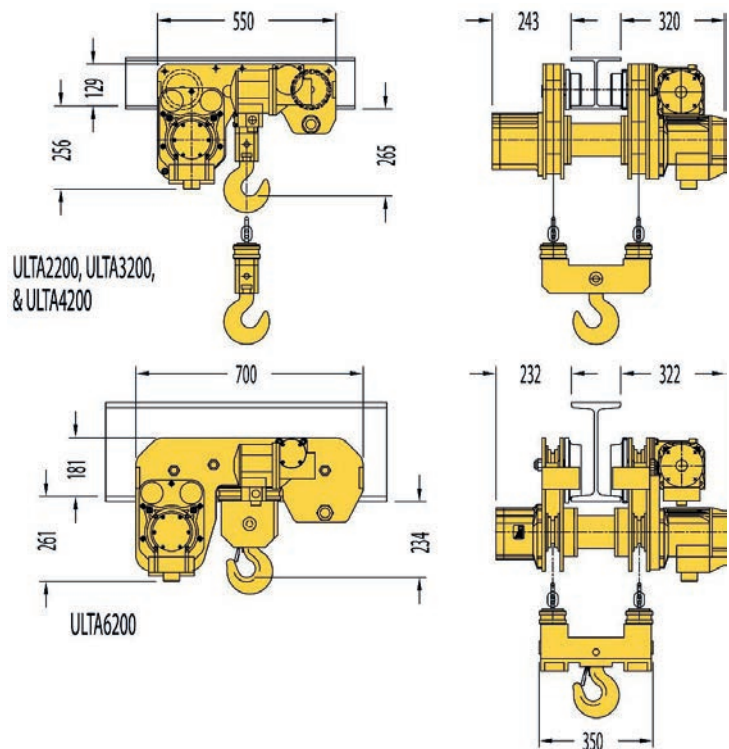



# Air trolleys



T series trolleys are designed specifically for mining, industrial and general engineering applications. The trolleys are available in plain, geared and motorized versions and can be supplied with rigid or hook on adaptors. They have a minimum factor of safety of 5 at the maximum rated load and are therefore suitable for use with both manual and powered hoists. The trolleys comply with the requirements of SANS 1824, EN13157 and EN1449-2. The manufacturing facility producing the trolleys is ISO9001, ISO14001 & OHSAS18001 certified.



PNEUMATIC HOISTING

Scan QR code for more technical information including drawings.

- 1, 3 and 6 tonne capacity units
- Low headroom, compact and versatile
- Available in plain, geared and motorized versions
- Greater than 5:1 factor of safety
- Anti-fall, anti-derailment and anti-tilt features as standard

Product Code	Capacity (tonne)	Track width range (mm) A	Min. curve radius (mm)	Net Weight (kg)	Max. Traverse Speed (m/min) @ 6 bar
TA1000	1.0	73-152	900	30.5	22.0*
TG1000	1.0	73-152	900	21.2	-
TP1000	1.0	73-152	900	18.2	-
TA3000	3.0	89-184	950	44.0	28.0*
TG3000	3.0	89-184	950	34.7	-
TP3000	3.0	89-184	950	31.7	-
TA6000	6.0	128-184	1600	80.0	27.0*
TG6000	6.0	128-184	1600	72.0	-
TP6000	6.0	128-184	1600	69.0	-

# Air winch



- Range - 0.5, 1, 2 & 3 tonne
- Reliable, fast efficient and quiet
- Compact design
- Extended drum versions available for increased rope capacity
- Easy to mount
- Greater than 5:1 factor of safety

Technical Specifications at 6 bar	WAR500I	WAR1000I	WAR2000I	WAR3000I
Half Drum Line Pull (kg)	500	1000	2000	3000
Rope Speed at Rated Load (m/min)	28.10	13.90	6.70	4.60
Full Drum No Load Speed (m/min)	60.30	28.20	18.50	9.00
Air Consumption (m <sup>3</sup> /min)	4.0	4.0	4.0	4.0
Air Connection	G 3/4	G 3/4	G 3/4	G 3/4
Supply Hose (Inside ø) (mm)	25	25	25	25
Sound Level (dB(A))	80	80	80	80
Recommended Rope Size (mm)	13.0	13.0	15.0	18.0
Rope Storage Length (m)- Standard Drum	80	80	59	52
Rope Storage Length (m)- Extended Drum	165	165	119	106
Weight without Wire Rope (kg) - Std	104	104	104	104

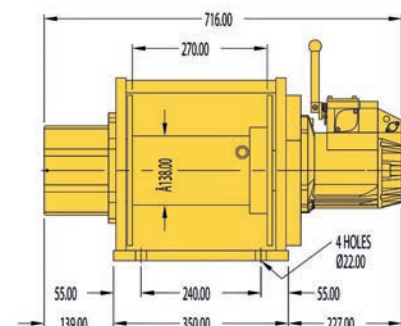
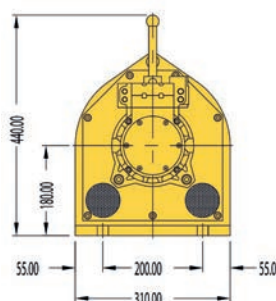

# Chain blocks and lever hoists overview

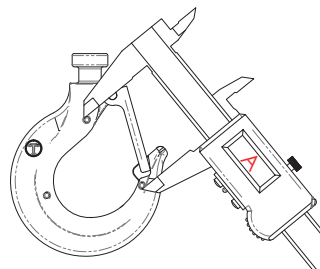
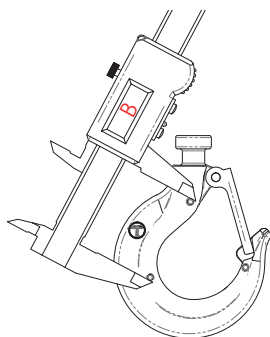

## Hooks:

Our hooks incorporate our latest patented “EZ Check” feature which allows operators and inspection engineers to easily check to see if the hoist has been previously overloaded or shock loaded by simply measuring between the triangle of pop marks. With this system a quick check that the A and B measurements are the same (as shown in the diagram above) will indicate if the hooks have stretched: If  $A \leq B$  the hook is fine; If  $A > B$  the hook needs to be replaced.

They are drop forged and heat treated alloy hooks with heavy duty spring latch kits that fully engage into the recessed nose of the hook safeguarding the load when side loading of the latch occurs and offering maximum load security. The swivel hooks are attached to the yoke using high grade nuts & bolts allowing for complete inspection during any statutory inspection or written scheme maintenance. The entire hook fitting has been protected using corrosion protected or stainless steel fixtures and fittings.

## Certification:

Each unit comes fully certified with a test certificate or an EC Declaration of Conformity stating compliance with the essential health and safety requirements of the Machinery Directive 2006/42/EC. This document clearly states the proof test at 1.5 times the rated capacity and the light load test of 2% of the rated capacity, which exceeds the requirements of the current applicable standard. Finish: Tiger hoists are finished in our high quality powder coat paint offering excellent corrosion protection.

## Load chains:

Tiger only use the highest quality alloy, calibrated load chains in Grade T or VH conforming to EN818-7 and ISO 16872. Our hoists are also available with stainless steel load chain.

## Finish:

Tiger hoists are finished in our high quality powder coat paint offering excellent corrosion protection

## Phosphor bronze bearings:

The Tin content increases the corrosion resistance and strength of the alloy, the Phosphorus increases the wear resistance and stiffness of the alloy. Needle Bearings have been proven to be unstable and unsuitable for offshore and marine environments.



## Multi fall load sheave bearings:

We have incorporated DU® self-lubricating metal polymer bearings into our multi chain fall load sheaves. Their success lies in the unique composite bearing structure comprised of a steel backing for mechanical strength and a porous sintered bronze interlayer impregnated with PTFE and lead for high wear resistance and extremely low friction properties. This makes them ideally suited to hoists used subsea. They provide improved energy efficiency due to low friction of PTFE-enriched overlay and have an extended service life with a strong wear-resistant bronze layer. There is zero maintenance as self-lubricating bearings can operate perfectly dry but have greater reliability with lubricant to avoid potential shaft/bearing seizure under boundary conditions.



**Performance:**

Tiger chain blocks and lever hoists have undergone a full test program that includes:

**Type Testing**

- Ultimate strength test, at least 4 times the Working Load Limit (WLL)
- Continuous cyclic testing of over 1500 cycles
- Chain end anchorage test, passing at least 2.5 times the WLL without any restriction of the brake or gears

**Test on every hoist**

- Proof loading at 1.5 times the rated capacity
- Light load testing at maximum of 2% rated capacity

**Cross hauling/fleeting operations:**

Chain blocks and lever hoists fitted with our patent protected Quad Cam brake system have undergone a full and comprehensive testing regime that was drawn up by industry specialists and Tiger's mechanical engineers to provide evidence that these units can be safely used for fleeting and cross-hauling applications up to 60° without de-rating.

**Brake efficiency:**

Tiger hoists utilise an 8 point multi-start thread pinion shaft which doubles the lead distance compared with typical 4 point threaded shafts, increasing the brake efficiency by 100%. The rotational engagement of the brake works with the direction of the load sheave creating highly efficient braking ratios. With our fine manufacturing tolerances between the pinion shaft thread and critical brake components we have engineered out a known failure mode where contamination to the threads can lead to brake failure or slippage.



Globally patent protected

**Quad cam brake design:**

Our patented braking system feature has been designed by Tiger to enhance the safety of our lever hoists and chain blocks. This unique design ensures there is always permanent engagement of one of the pawls in the ratchet wheel. The reciprocating action always forces the pawl into the gear even without a pawl spring. This ensures the brake is always fully functional. With a conventional twin pawl brake mechanism (tear drop design) failure can occur if the pawl spring erodes, fractures or a shock load bounces the pawls out of the ratchet gear. Without the spring these systems rely on gravity keeping the pawls engaged and are flawed when the hoist is used at angles away from the vertical. Our quad cam pawl system is fitted to PROCB/SS20 chain blocks and PROLH/SS19 lever hoists.

**Overload protection:**

If the exact load can't be accurately determined then consider using hoists with slipping clutch overload protection. If the chain block or lever hoist is fitted with a slipping clutch overload mechanism then it is protected from overload. When the load limit is exceeded, the clutch in the chain wheel will slip, allowing the hand wheel to be rotated or handle to be operated whilst not engaging the gear box. This prevents further lifting of the load, though lowering is still possible. Load limiters can be fitted to PROCB/SS20 chain blocks and PROLH/SS19 lever hoists. Tiger chain blocks and lever hoists fitted with overload limiters are DNV GL Verification tested according to NORSOK R-002.





# Adaptable chain blocks and lever hoists



360° rotation and 180° pivot for maximum flexibility

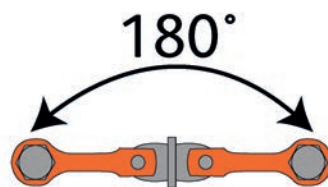

- Available for Tiger PROCB/SS20 chain blocks and PROLH/SS19 lever hoists
- All fittings meet the standards of EN1677 grade 100 at 400°C tempering
- Drop forged adaptor for maximum strength certified 4:1 FOS at all angles
- Self-locking (safety) hook, clevis shackle, reeveable egg (master) link or sling hook fitting available
- Overload protection available
- For lifting at angles (cross hauling / fleeting / drifting) with no deration
- Chain Blocks – 500kg – 10t capacity
- Lever Hoists – 500kg – 10t capacity



Additional adaptable fittings for PROCB/SS20 chain blocks and PROLH/SS19 lever hoist. To replace the top hook, bottom hook or both hooks



Clevis self-locking hook



Clevis shackle



Clevis sling hook



Clevis reeveable egg/master link



500kg lever hoist with clevis self locking hook



MANUAL HOISTING

# Spark resistant chain blocks and lever hoists



Ex II 2 GD c IIC T4 IIIC T135°C.

In many areas of industry, plants are operated with potentially explosive atmospheres. Due to the very high risk to personal and other assets, extremely strict guidelines and technical requirements are in place in explosive zones. Tiger Spark Resistant products are manufactured in accordance with ATEX Directive 2014/34/EU and the Machinery Directive 2006/42/EC. Our products are lightweight and durable with a proven track record.

Atex marking: Ex II 2 GD c IIC T4 IIIC T135°C. Suitable for gas and dust hazardous areas: Zone 1 & 2 (gas) and Zone 21 & 22 (dust).

We can supply chain blocks, lever hoists, beam clamps, trolleys and combination block and trolley units.

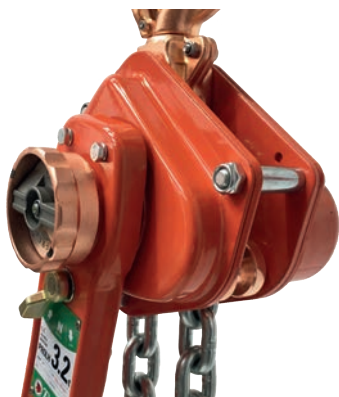

- Category II – high safety - Certification: Ex II 2 GD c IIC T4 IIIC T135°C
- Manufactured in accordance with ATEX Directive 2014/34/EU and Machinery Directive 2006/42/EC
- Developed for the use in potentially explosive atmospheres (ATEX zones)
- Special coated unit
- Different capacities and heights of lift to suit your specific requirements
- Available with stainless steel load chain
- Available with overload protection

Note: It is the responsibility of the user to identify which explosion proof classification is required, not the hoist manufacturer or supplier.





- Stainless steel hand chain (chain blocks)
- Corrosion protected load chain
- Marine specific friction discs
- Brake chamber protection from outside contamination
- Copper plated suspension and load hooks, load chain guides, grip rings, hand wheels and end anchorage
- Stainless steel fixings and fasteners
- Lever hoist also available using our PROLH unit and standard load chain
- Operating temperature -40°C to +80°C (temperature range of -60°C to +80°C available as an option)



MANUAL HOISTING

Combined chain blocks and trolleys available

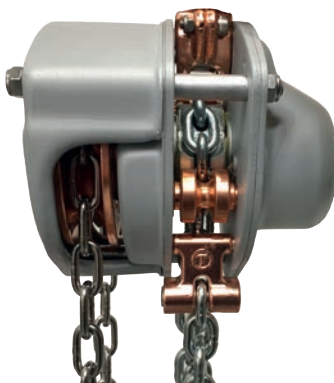

Ex II 2 GD c IIC T4 IIIC T135°C

II	2	GD	c	IIC	T4	IIIC	T135°C		
								T135°C	Dust Temperature Class: Maximum external surface temperature 135°C
								IIIC	Groups of Dust: Protected for group IIIC which includes groups IIIA & IIIB
								T4	Gas Temperature Class: Maximum external surface temperature 135°C
								IIC	Gas Explosion Group: Protected for group IIC which includes groups IIA & IIB
								c	Protection type: Design safety
								GD	Ex Atmosphere: Gas and Dust
								2	Category: High Safety
								II	Equipment Group: surface industries

# Lever hoists



All our lever hoists are manufactured from the highest quality materials precisely machined in our own factory, producing strong products with high resistance to impact damage. The hoists are finished in our high quality powder coat paint offering excellent corrosion protection. This all ensures they are ideal hoists for long-term use with less maintenance and servicing costs. The strong impact resistant gearbox housing, complete with close tolerance fit bearings that fully support the pinion shaft and planet gears, maintains smooth revolutions whilst under load. High gear ratios keep physical effort to a minimum; this provides maximum mechanical efficiency.

These units meet and exceed all the requirements within BS EN 13157: 2004+A1:2009, ANSI/ASME B30.21, AS1418.2 and SANS 1636.

## Industrial TRLH



- Range from 750kg-6.0t
- Drop forged and heat treated alloy hooks
- Safe reliable twin pawl mechanical brake
- High quality alloy calibrated load chain
- Proof tested to 1.5 times rated capacity
- Guaranteed light load protection
- 1.5m height of lift as standard but can be chained to exact requirements
- Optional extra heavy duty chain end stop

## Mini Series



- 250kg and 500kg units
- Safe and reliable twin pawl mechanical brake
- Rugged steel body construction
- Lightweight and portable
- 360 degree handle rotation
- Short stroke and low lever pulling effort
- Easy single-hand "freewheeling" operation
- Guaranteed light load protection
- Heat treated alloy steel triple spur gears and pinion shaft
- Operating temperature -40°C to +80°C (temperature range of -60°C to +80°C available as an option)
- Supplied with useful belt bags

## Professional PROLH



UK Network Rail  
PADS Certification

- Range from 800kg –20.0t
- Patented Quad Cam Pawl System
- DNV GL Verification tested according to NORSOK R-002
- Available with slipping clutch overload protection
- Available with forged clevis adaptor components
- Equipped with our unique torsion brake mechanism
- One piece construction pinion gear
- No requirement for preload tension to activate the ratchet mechanism
- Light load tested and certified at 2 % of the rated capacity
- Adaptable to use both inverted and horizontally
- Individual spares readily available
- Operating temperature -40°C to +80°C (temperature range of -60°C to +80°C available as an option)
- All major parts are heat treated and precisely machined
- Finished in high quality powder coat paint offering excellent corrosion protection
- Can be chained up to meet your exact requirements
- Phosphor bronze bearings
- Adjustable chain end anchorage available as an option
- Also available with stainless steel load chain or spark resistant hooks
- Available with shipyard hooks. in 1.6t & 3.2t capacities.
- Available with load bearing swivel hooks to meet relevant standards i.e. AS 1418.2
- Fleeting angle up to 60° from the vertical without deration





SS19 and PROLH gearboxes contain one-piece pinion gears giving unprecedented strength in the harshest environments.



8 point multi-start thread pinion shaft on all our lever hoists and chain blocks- doubles the lead distance compared with typical 4 point threaded shafts, increasing the brake efficiency by 100%.

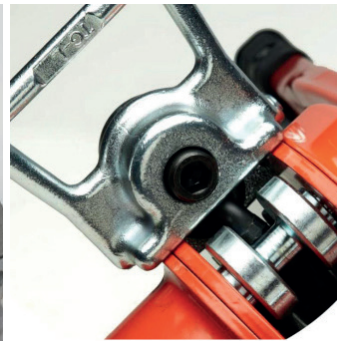

User friendly heavy duty end stops on our PROLH (and as an option on our TR7) make it easy for the operator to position the chain while "freewheeling". Most importantly this "end stop" will hold a load of at least 2.5 times the rated capacity when supporting the full load without restraint from other components e.g. brake or gearing.



Tiger Professional and Specialist lever hoists have our unique rotational inertia driven torsion brake system. The unique brake system guarantees a light load protection at 2% of the rated capacity.

## Specialist SS19



- Range from 800kg –20.0t
- All the features of the PROLH as well as the following:
- Suitable for use in multi-immersion applications (see p25)
- Meets and exceeds IMCA DO28 Rev 2 guidance notes for offshore lever hoists
- New even harder-wearing paint finish in accordance with ISO12944 C5M
- Marine specific friction discs
- Full face gasket provides brake chamber protection from outside contamination
- Fully corrosion protected body and components to ensure reliable long-term use
- Over 1500 hours protection to ASTM B117 conditions
- Adjustable chain end anchorage specifically designed to the contours of the hoist
- New technology high performance grease
- Fleeting angle up to 60° from the vertical without deration

Download our technical sheet for more details:



Tiger have incorporated the ultimate safeguarding of a single point failure mode as described in IMCA DO28 Rev. 2 Note 7.2 by installing a specially designed adjustable chain end stop. Tiger have specifically profiled and manufactured this item to fit the contours of the SS hoist. This offers complete assurance to the operator, whilst maintaining the flexibility of "freewheeling" the chain to any required starting position.

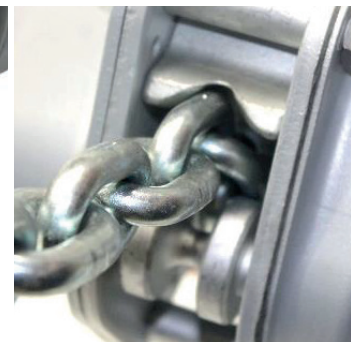

The fluted chain stripper is specifically designed to guide the load chain safely onto or off the load sheave. The critical configuration of, and distance between, the chain stripper and the roller guide ensures alignment of the chain so it cannot snag or jam. This allows the safe use of the SS19/PROLH when used in any orientation.

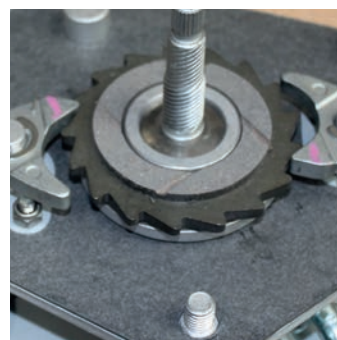

The SS19 has bonded marine friction discs developed and designed for subsea use creating a highly efficient, reliable braking surface for use in the most extreme conditions.



Precisely engineered side plates and components protected by a full gasket give the SS19 brake chamber and contents maximum protection from external contamination. Phosphor bronze bearings are ideally suited to offshore marine environments.



Mini Series

Product Code	Capacity (tonne)	Effort (kg)	Dimensions (mm)							Load Chain		Standard HOL (m)	Weight @ std HOL (kg)	Weight for extra metre HOL (kg)
			A	B	C	D	E	F1	F2	Diameter (mm)	No. of falls			
LH-0025	0.25	30	60	168	245	85	66	22	31	4.0	1	1.5	2.0	0.3
LH-0025H	0.25	15	89	168	265	113	70	22	31	4.0	1	1.5	2.9	0.3
LH-0050	0.50	30	89	168	280	113	70	24	38	4.0	1	1.5	3.0	0.3

Industrial TRLH

Product Code	Capacity (tonne)	Effort (kg)	Dimensions (mm)							Load Chain		Standard HOL (m)	Weight @ std HOL (kg)	Weight for extra metre HOL (kg)
			A	B	C	D	E	F1	F2	Diameter (mm)	No. of falls			
TRL-0075	0.75	22	128	240	275	158	99	24	38	6.3	1	1.5	7.5	0.9
TRL-0100	1.0	29	128	240	295	158	99	28	45	6.3	1	1.5	7.5	0.9
TRL-0150	1.5	26	154	360	320	172	104	34	51	7.1	1	1.5	10.0	1.1
TRL-0200	2.0	35	154	360	367	172	104	35	53	7.1	1	1.5	10.5	1.1
TRL-0300	3.0	38	182	360	400	195	108	36	56	10.0	1	1.5	18.0	2.2
TRL-0600	6.0	40	242	360	570	195	108	49	70	10.0	2	1.5	29.5	4.3

Professional PROLH

Product Code	Capacity (tonne)	Effort (kg)	Dimensions (mm)							Load Chain		Standard HOL (m)	Weight @ std HOL (kg)	Weight for extra metre HOL (kg)
			A	B	C	D	E	F1	F2	Diameter (mm)	No. of falls			
PLH-0080	0.8	23	128	240	295	158	99	28	45	6.3	1	1.5	7.5	0.9
PLH-0160	1.6	28	154	360	320	172	104	34	51	7.1	1	1.5	10.5	1.1
PLH-0320	3.2	40	182	360	400	195	108	36	56	10.0	1	1.5	18.0	2.2
PLH-0630	6.3	42	242	360	570	195	108	49	70	10.0	2	1.5	28.5	4.3
PLH-0800	8.0	38	379	360	580	195	108	51	78	10.0	3	1.5	43.0	6.5
PLH-1000	10.0	47	379	360	630	195	108	54	87	10.0	3	1.5	46.0	6.5
PLH-1500	15.0	44	566	360	840	195	108	59	81	10.0	5	1.5	112.0	10.8
PLH-2000	20.0	49	457	360	1050	250	160	81	110	10.0	6	1.5	156.0	13.1



Available with clevis adaptor fittings (see page 20) and load limiters on request.



Mini Series

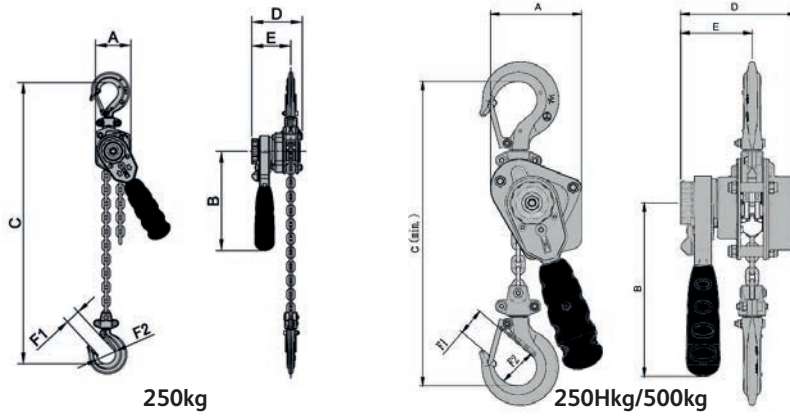

250kg

250kg/500kg

TRLH & PROLH

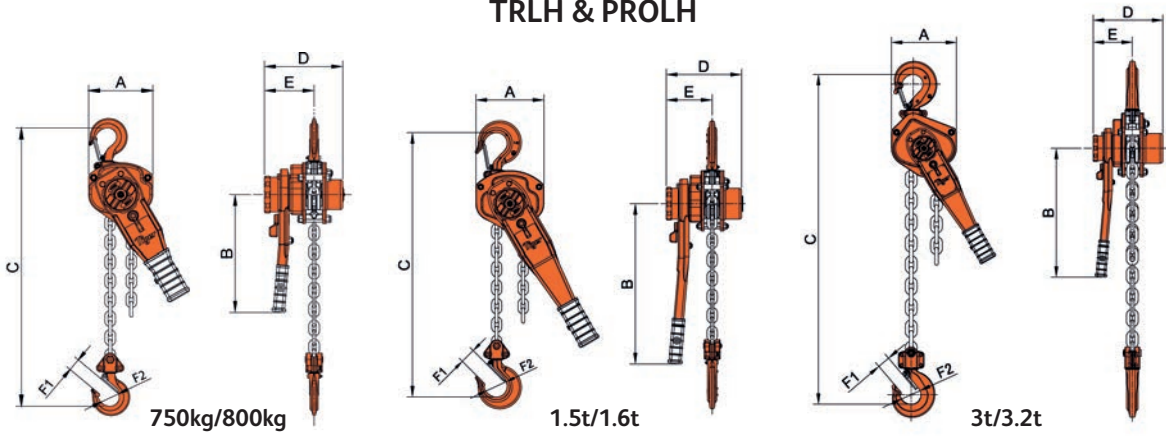

750kg/800kg

1.5t/1.6t

3t/3.2t

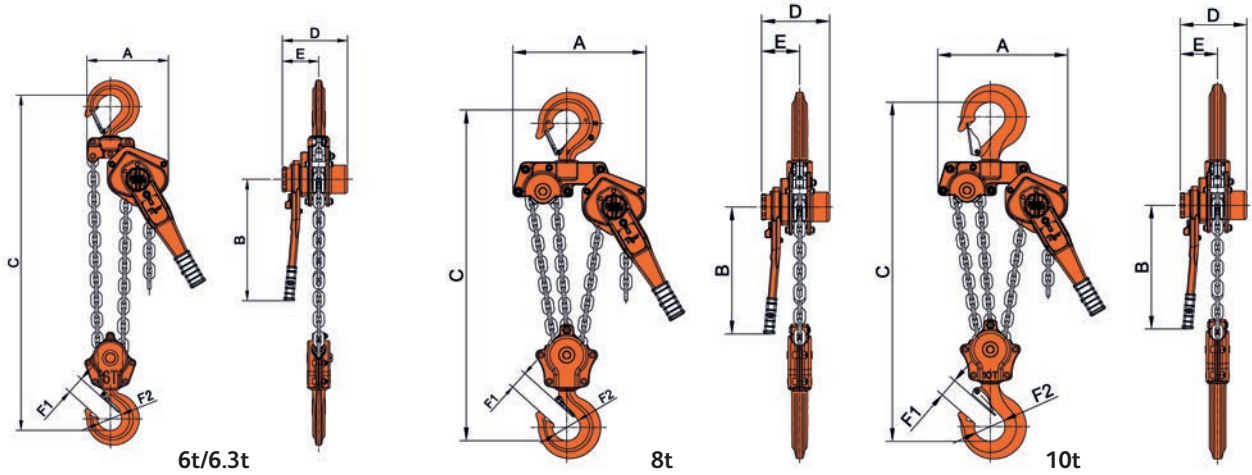

6t/6.3t

8t

10t

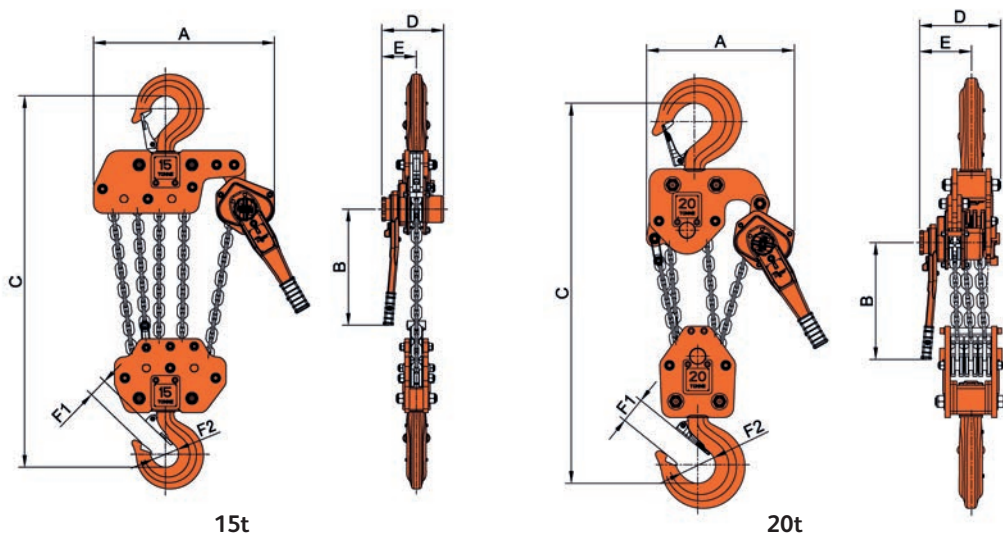

15t

20t

Specialist SS19

Product Code	Capacity (tonne)	Effort (kg)	Dimensions (mm)							Load Chain		Standard HOL (m)	Weight @ std HOL (kg)	Weight for extra metre HOL (kg)
			A	B	C	D	E	F1	F2	Diameter (mm)	No. of falls			
SS-0080	0.8	23	128	243	295	158	99	28	45	6.3	1	3	9.0	0.9
SS-0160	1.6	28	154	370	320	172	104	34	51	7.1	1	3	12.5	1.1
SS-0320	3.2	40	182	370	400	195	108	36	56	10.0	1	3	22.0	2.2
SS-0630	6.3	42	242	370	570	195	108	49	70	10.0	2	3	34.5	4.3
SS-0800	8.0	38	379	370	580	195	108	51	78	10.0	3	3	52.0	6.5
SS-1000	10.0	47	379	370	630	195	108	54	87	10.0	3	3	55.0	6.5
SS-1500	15.0	44	566	370	840	195	108	59	81	10.0	5	3	128.0	10.8
SS-2000	20.0	49	470	370	1050	250	160	81	110	10.0	6	3	174.0	13.1

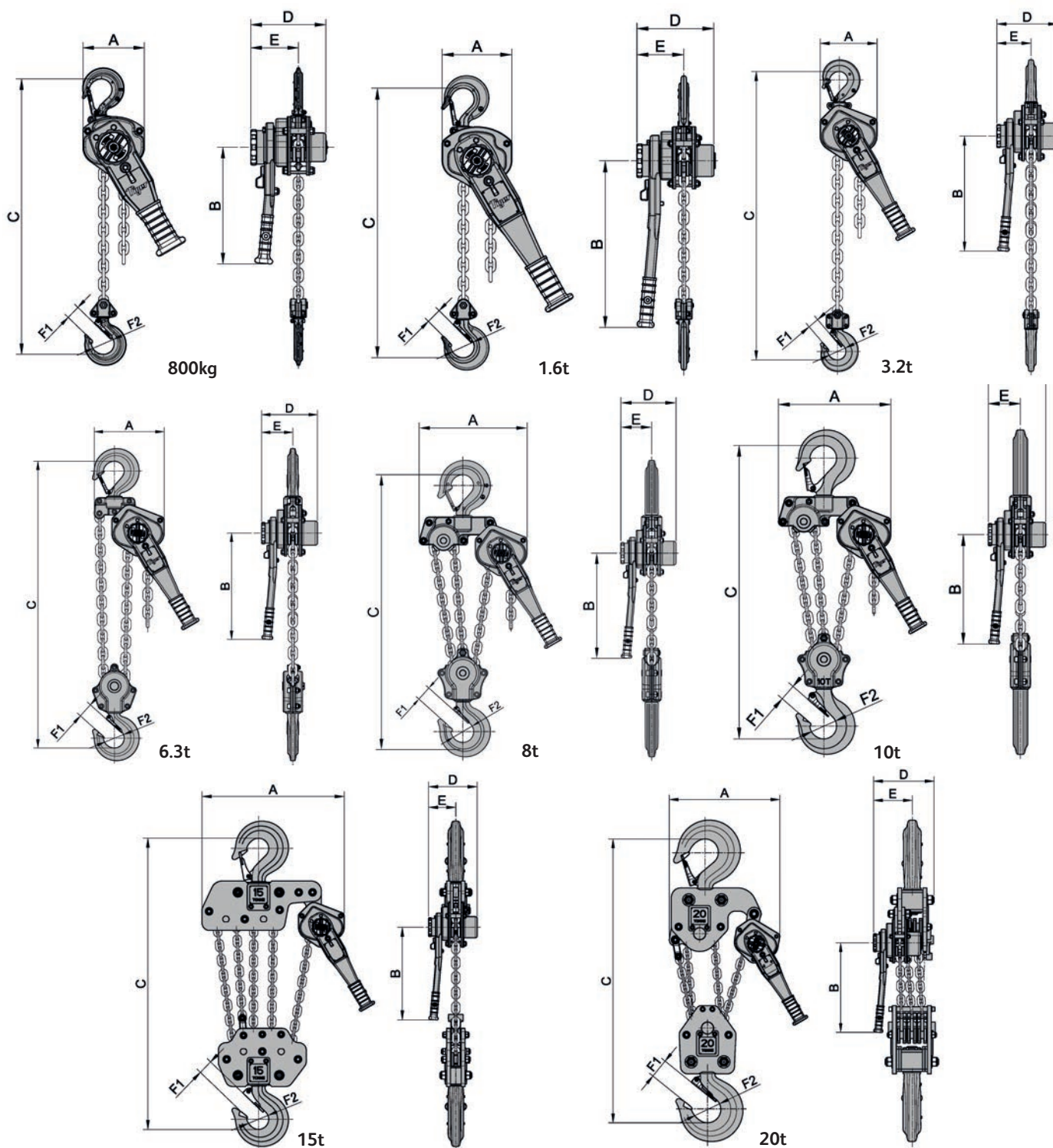



# Subsea & multi-immersion



After successfully completing a series of third party verification and testing programmes, our latest being a multi-immersion programme of tests over 54 days developed and agreed by industry professionals and independently carried out and verified at ORE Catapult in the UK (a leading technology innovation and research centre for offshore renewable energy), we can state that the Tiger SS range of lever hoists and chain blocks are suitable for use in multi-immersion applications providing the timescales, pre-use testing, maintenance and service requirements as detailed in Tiger document Multi-Immersion Instruction Manual are strictly followed.



MANUAL HOISTING



We used a subsea dock including a replica seabed



Saltwater was pumped in from the Blyth Estuary (North Sea)

We have also carried out intensive internal testing to ensure we achieved over 1500 hours protection to ASTM B117 conditions. This ensures the performance of the SS ranges has been fully challenged in natural environments similar to the conditions they will be exposed to.



Tiger SS19 and SS20 hoists are completed with a two-stage finish combining electroplating as a base layer and then finished with a very hard-wearing sand texture powder coating paint which offers excellent corrosion protection and high impact protection ideally suited for multi-immersion applications. Paint finish in accordance with ISO12944 C5M.

We use new-technology, wide temperature range, high performance premium grease. It contains no heavy metals or other harmful or environmentally undesirable additives. This selection achieves the correct viscosity to prevent the grease migrating from the area of application. Even when mixed with 50% high water absorption it has excellent adhesion and no sign of breakdown after 100,000 strokes and remains unchanged with no slump or breakdown unlike other "premium" greases. Load carrying ability, mechanical stability, corrosion protection, water resistance and increased operating temperature ranges are all improved by the using only the very best lubricant.

Standard operating temperature range -40°C to +80°C - far exceeding the requirements of current standards. Ultra-low operating temperature units also available to -60°C.



We have incorporated DU® self-lubricating metal polymer bearings into our multi chain fall load sheaves. Their high wear resistance and extremely low friction properties makes them ideally suited to hoists used subsea.



Our latest forged latches incorporate a new wing design making them easier to operate in the operation area (e.g. wet gloved hands for offshore or subsea use).



Tiger only utilise phosphor bronze bearings on hoists. The tin content increases the corrosion resistance and strength of the alloy, the phosphorus increases the wear resistance and stiffness of the alloy. This makes them ideally suited for subsea environments.

# Chain blocks



All chain blocks are manufactured from the highest quality materials precisely machined in our own factory, offering a lightweight, compact and rugged construction; producing an exceptionally strong product resistant to impact damage. The especially low headroom allows for easy installation in the most restricted environments and all units come with drop forged and heat treated alloy hooks. The highly efficient brake systems work instantly when the operation is stopped and securely holds the load. Loads are lowered under perfect control, allowing for precise operations. Tiger chain blocks easily pass the brake lock out test as per BS 3243:1990 with a 2% load of the rated capacity. PROCB and SS20 are available with forged clevis adaptor components. They can be chained to any height of lift to meet exact requirements and individual spares are readily available. The PROCB/SS20 chain block top hook can be replaced by a competent person so the block can be directly fitted to our beam trolley range of the equivalent capacity achieving the lowest possible headroom. All chain blocks meet or exceed all international standards within BS EN 13157:2004+A1:2009, ANSI/ASME B30.16, AS1418.2 and SANS 1594.

## Industrial TRCB



- Range from 500kg-5.0t
- Safe and reliable twin pawl mechanical brake
- Operating temperature -25°C to +80°C
- Double cover protection for break cover

## Professional PROCB



- Range from 250kg-35.0t
- Patented Quad Cam Pawl System
- DNV GL Verification tested according to NORSOK R-002
- Operating temperature -40°C to +80°C (temperature range of -60°C to +80°C available as an option)
- Double cover protection for break cover
- Tested and certified for “fleeting” “drifting” and “cross-hauling” applications up to 60° from the vertical without deration
- Suitable for underground mining use
- Available with slipping clutch overload protection
- Optional chain carrier
- Phosphor bronze bearings

## Specialist SS20



- Range from 500kg-35.0t
- All the features of the PROCB as well as the following additional features:
- Suitable for use in multi-immersion applications (see p21)
- Corrosion protected load and hand chain
- Marine specific friction discs
- Marine chain bags available on request
- Fully corrosion protected body and components to ensure reliable long term use
- Stainless steel fixings and fasteners
- New technology high performance grease
- Winged design latches for easier operation
- Ultra-low operating temperature units available
- Tested and certified for “fleeting” “drifting” and “cross-hauling” applications up to 60° from the vertical without deration



250kg PROCB

See our technical sheet for full details:





Double Cover Protection on all our chain blocks: both the hand chain wheel cover and the ratchet brake cover are designed to offer protection to the brake chamber in the harshest environments from foreign objects.

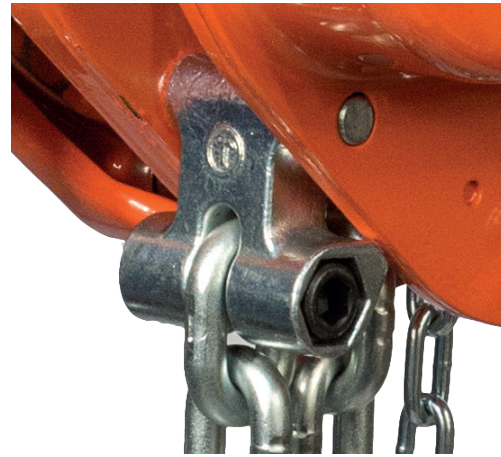

Our chain end anchors will hold a load of at least 2.5 times the rated capacity when supporting the full load without restraint from other components e.g. brake or gearing. This prevents accidents, by acting as a stop when the lift length of the load chain is exceeded when lowered. The image shows our special strong and contoured design used on our PROCB and SS20 ranges.

MANUAL HOISTING



For chain blocks to be used up to an angle of 45 degrees, it's critical that the hand chain leaves and enters the hand wheel without twisting, snagging or jamming. Thanks to our specially designed deep-profile chain block hand wheel this is achievable as it helps to seat the chain no matter what angle or direction of pull.



Our specialist SS20 has unique corrosion protection of all the internal parts including load and hand chain, ensuring over 1500 hours continuous protection under ASTM B117 Salt spray conditions.



Recessed forgings offer full protection to the load chain anchor bolts on all our bottom hooks. Load sheave protected design on all multi fall hooks.



Optional chain carrier.



Available with clevis adaptor fittings (see page 20) and load limiters on request.

**Industrial TRCB**

Product Code	Capacity (tonne)	Effort (kg)	Dimensions (mm)							Load Chain		Standard HOL (m)	Weight @ std HOL (kg)	Weight for extra metre HOL (kg)
			A	B	C	D	E	F1	F2	Diameter (mm)	No. of falls			
TRC-0050	0.5	21	93	66	305	52	78	24	38	6.3	1	3	10.5	1.9
TRC-0100	1.0	25	93	66	340	63	87	28	45	6.3	1	3	11.5	1.9
TRC-0150	1.5	32	98	73	385	78	102	34	51	7.1	1	3	16.0	2.1
TRC-0200	2.0	34	101	79	420	87	113	35	53	8.0	1	3	20.0	2.4
TRC-030T	3.0	34	98	73	488	60	148	36	56	7.1	2	3	23.0	3.2
TRC-0500	5.0	37	101	79	575	122	209	49	70	8.0	3	3	37.5	5.2

**Professional PROCB**

Product Code	Capacity (tonne)	Effort (kg)	Dimensions (mm)							Load Chain		Standard HOL (m)	Weight @ std HOL (kg)	Weight for extra metre HOL (kg)
			A	B	C	D	E	F1	F2	Diameter (mm)	No. of falls			
CB-0025	0.25	17	64	40	240	36	60	22	31	4.0	1	3	3.8	0.5
CB-0050	0.5	21	93	66	305	52	78	24	38	6.3	1	3	10.5	1.9
CB-0100	1.0	25	93	66	340	63	87	28	45	6.3	1	3	11.5	1.9
CB-0150	1.5	32	98	73	385	78	102	34	51	7.1	1	3	16.0	2.1
CB-0200	2.0	34	101	79	420	87	113	35	53	8.0	1	3	20.0	2.4
CB-020L	2.0	42	98	73	399	78	102	35	53	7.1	1	3	16.5	2.1
CB-0300	3.0	38	109	84	500	98	157	36	56	10.0	1	3	30.5	3.2
CB-030T	3.0	34	98	73	488	60	148	36	56	7.1	2	3	23.0	3.2
CB-0500	5.0	37	101	79	575	122	209	49	70	8.0	3	3	37.5	5.2
CB-0600	6.0	38	109	84	635	86	220	49	70	10.0	2	3	45.5	5.3
CB-0800	8.0	34	109	84	610	153	263	51	78	10.0	3	3	61.0	7.5
CB-1000	10.0	40	109	84	660	153	263	54	87	10.0	3	3	64.0	7.5
CB-1500	15.0	41	109	84	840	225	378	59	81	10.0	5	3	128.5	11.8
CB-2000	20.0	43	161	90	1050	148	360	81	110	10.0	6	3	178.5	14.2
CB-200T	20.0	43	161	161	1050	383	383	81	110	10.0	6	3	210.5	15.2
CB-3000	30.0	42	220	220	1200	390	390	91	135	10.0	10	3	307.0	23.8
CB-3500	35.0	40	240	240	1200	390	390	91	135	10.0	12	3	365.0	27.0

**Specialist SS20 (also used for ROV compatible chain block)**

Product Code	Capacity (tonne)	Effort (kg)	Dimensions (mm)							Load Chain		Standard HOL (m)	Weight @ std HOL (kg)	Weight for extra metre HOL (kg)
			A	B	C	D	E	F1	F2	Diameter (mm)	No. of falls			
SCB-0050	0.5	21	93	66	305	52	78	24	38	6.3	1	3	10.5	1.9
SCB-0100	1.0	25	93	66	340	63	87	28	45	6.3	1	3	11.5	1.9
SCB-0150	1.5	32	98	73	385	78	102	34	51	7.1	1	3	16.0	2.1
SCB-0200	2.0	34	101	79	420	87	113	35	53	8.0	1	3	20.0	2.4
SCB-0300	3.0	38	109	84	500	98	157	36	56	10.0	1	3	30.5	3.2
SCB-0500	5.0	37	101	79	575	122	209	49	70	8.0	3	3	37.5	5.2
SCB-0600	6.0	38	109	84	635	86	220	49	70	10.0	2	3	45.5	5.3
SCB-0800	8.0	34	109	84	610	153	263	51	78	10.0	3	3	61.0	7.5
SCB-1000	10.0	40	109	84	660	153	263	54	87	10.0	3	3	64.0	7.5
SCB-1500	15.0	41	109	84	840	225	378	59	81	10.0	5	3	128.5	11.8
SCB-2000	20.0	43	161	90	1050	148	360	81	110	10.0	6	3	178.5	14.2
SCB-3000	30.0	42	220	220	1200	390	390	91	135	10.0	10	3	307.0	23.8

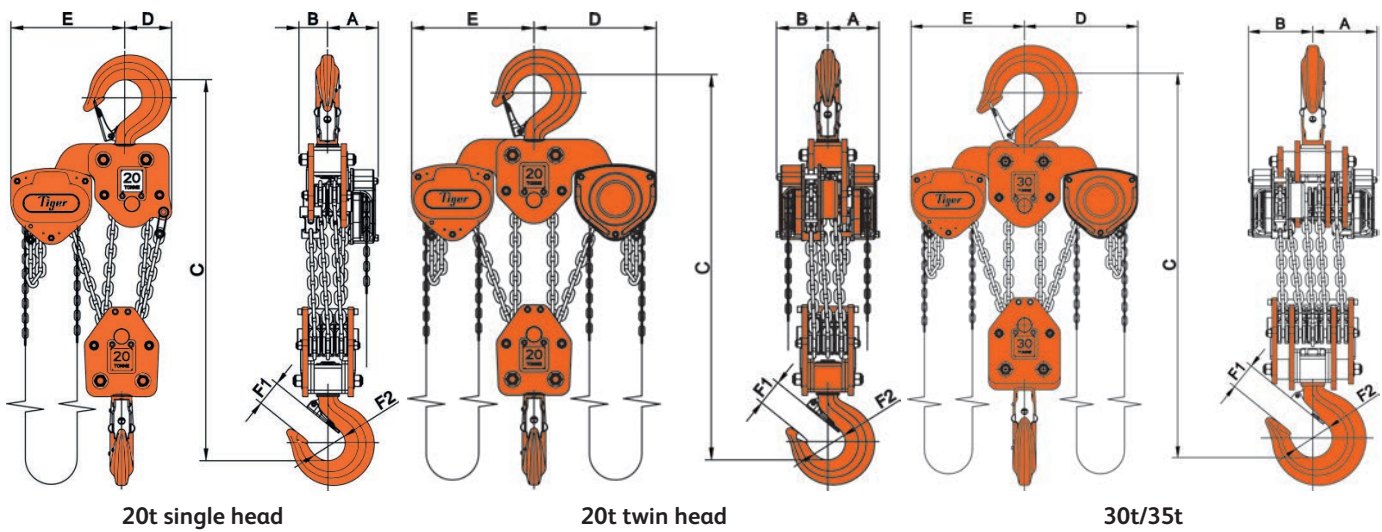
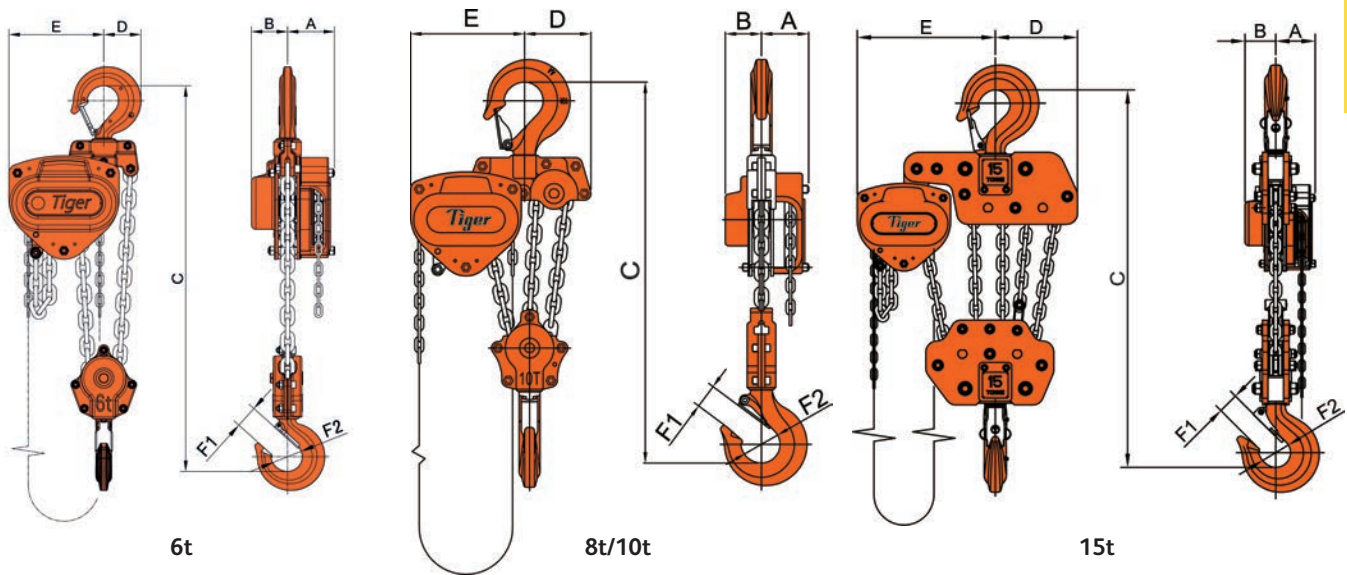
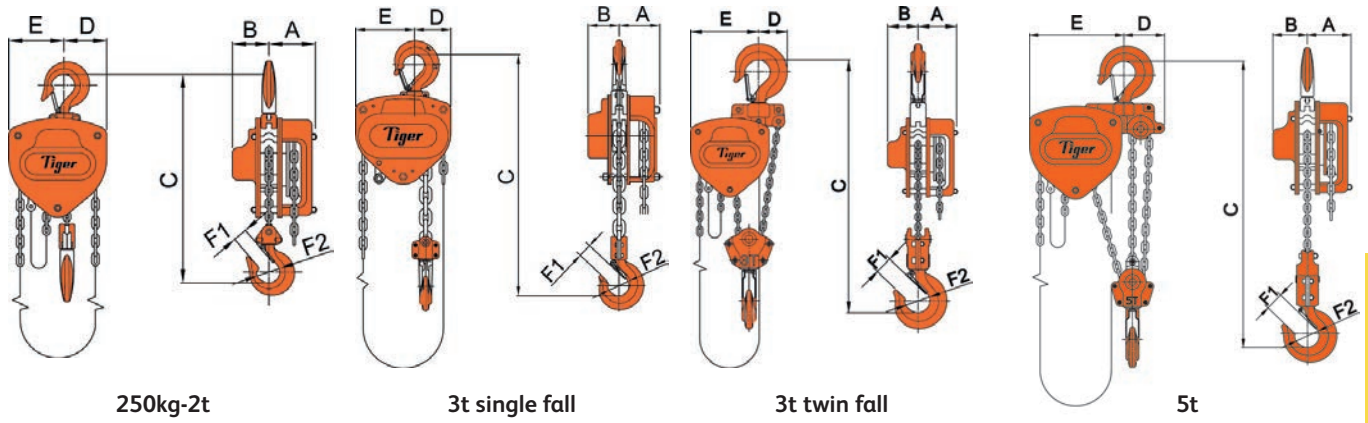

# ROV compatible chain block



The Tiger ROV compatible chain block is available in various different interface options all in accordance with BS ISO 13628-8:2002 ROV Interfaces on Subsea production systems. Tested and finished in accordance with Annexes B & K of BS ISO 13628-1:2005:

1. Hydraulic Hot Stab connection type A and B
2. Rotary Torque Receptacle Classes 1,2 & 3
3. D Handle, T-bar or Fishtail Direct Drive manual connection
4. QD Direct Drive Couplings

Available as a 3.0 tonne, 10 tonne, 15 tonne and 20 tonne (single head six fall) capacity chain blocks, chained up to project specific heights of lift (HOL) that can be pre-set to meet the exact starting point required within the rigging drawings. These units use our specialist SS20 chain block- see page 26 for details.



Stainless steel chain bucket option



Tiger ROV compatible chain blocks fitted with one piece construction gears

Bespoke products for special applications also available – let us know what you need.



QD direct drive couplings



Manual D handle interface



One of our torque receptacle options



## Quality machining

Strong impact resistant gearbox housing complete with close tolerance fit bearing that fully support the pinion shaft and planet gear to maintain smooth revolutions whilst under load, Subsea suitable bearings for top and bottom hook load sheaves are enclosed in drop forged housing assembled with stainless steel fittings.



High performance marine spec hydraulic system



New hand wheel feature



Strong impact resistant gearbox

### Chain block data table Please see page 33 for chain block technical drawings

Product Code	Capacity (tonne)	Effort (kg)	Dimensions (mm)							Load Chain		Standard HOL (m)	Weight @ std HOL (kg)	Weight for extra metre HOL (kg)
			A	B	C	D	E	F1	F2	Diameter (mm)	No. of falls			
SCB-0300	3.0	38	109	84	550	98	157	36	56	10.0	1	3	30.5	3.2
SCB-0600	6.0	38	109	84	635	86	220	49	70	10.0	2	3	45.5	5.3
SCB-0800	8.0	34	109	84	610	153	263	51	78	10.0	3	3	61.0	7.5
SCB-1000	10.0	40	109	84	660	153	263	54	87	10.0	3	3	64.0	7.5
SCB-1500	15.0	41	109	84	840	225	378	59	81	10.0	5	3	128.5	11.8
SCB-2000	20.0	43	161	90	1050	148	360	81	110	10.0	6	3	178.5	14.2
SCB-3000	30.0	42	220	220	1200	388	388	91	135	10.0	10	3	307.0	23.8

### ROV block data table

Product Code	Capacity (tonne)	Max Torque (Nm)	Revs per 300mm travel (max 125 RPM)	Time to raise 300mm at max RPM (Min:Sec)	Weight out of water (kg) (includes chain block @ std HOL)			
					Hot Stab	QD Drive	Torque Tool	Fishtail
RCB-0300	3.0	45	55	0:26	72.5	54.5	57.5	43
RCB-0600	6.0	TBA	110	0:59	87.5	TBA	TBA	TBA
RCB-0800	8.0	TBA	165	1:19	103	TBA	TBA	TBA
RCB-1000	10.0	50	165	1:19	106	84.5	87.5	76
RCB-1500	15.0	52	275	2:12	170.5	154.5	157.5	141
RCB-2000	20.0	55	340	2:43	220.5	202.0	205.0	190.5
RCB-3000	30.0	TBA	570	4:34	TBA	TBA	TBA	TBA

- 3.0t, 6.0t, 8.0t, 10.0t, 15.0t and 20.0t capacity units available
- Fully corrosion protected
- Compliant with BS ISO 13628-8:2002 & BS ISO 13628-1:2005
- Stainless steel 316 framework and handle
- Proven Subsea brake design
- Patented Quad Cam pawl system
- One-piece brake chamber cover
- Heavy duty flexible chain bag c/w stainless steel mounting frame
- 4 Point manipulator connection points
- One piece construction pinion gears
- Compact and light weight
- Balanced design for easy handling and installation
- Subsea suitable bearings for top and bottom hook load sheaves
- Marine specific friction discs
- New hand wheel feature for on-deck height of lift adjustments
- Bespoke chain lengths to meet exact customer requirements
- Full individual spares back up
- Each unit is fully tested and certified before delivery

See our technical sheet for full details:



For chain block information please see pages 30 - 33

**ROV chain block with D handle**

Product Code	Dimensions (mm)									
	A	B	C	D	E	F1	F2	G	H	M
RCB-030D	221	84	550	280	310	36	56	309	405	504
RCB-060D	221	84	703	221	369	49	70	309	467	504
RCB-080D	221	84	749	179	411	51	78	309	489	504
RCB-100D	221	84	660	185	405	54	87	309	515	504
RCB-150D	221	84	840	225	520	59	81	309	570	504
RCB-200D	221	90	1050	148	515	81	110	309	650	510
RCB-300D	332	220	1200	388	545	91	135	309	680	750

**ROV chain block with fishtail**

Product Code	Dimensions (mm)									
	A	B	C	D	E	F1	F2	G	H	M
RCB-030F	221	84	550	280	310	36	56	309	405	536
RCB-060F	221	84	703	214	376	49	70	309	467	536
RCB-080F	221	84	749	179	411	51	78	309	189	536
RCB-100F	221	84	660	185	405	54	87	309	515	536
RCB-150F	221	84	840	225	520	59	81	309	570	536
RCB-200F	221	90	1050	148	515	81	110	309	650	542
RCB-300F	332	220	1200	388	545	91	135	309	680	780

**ROV chain block with rotary torque**

Product Code	Dimensions (mm)									
	A	B	C	D	E	F1	F2	G	H	M
RCB-030T	106	84	550	280	310	36	56	309	405	390
RCB-060T	106	84	703	214	376	49	70	309	467	390
RCB-080T	106	84	749	179	411	51	78	309	489	390
RCB-100T	106	84	660	185	405	54	87	309	515	390
RCB-150T	106	84	840	225	520	59	81	309	570	390
RCB-200T	158	90	1050	148	515	81	110	309	650	448
RCB-300T	216	220	1200	388	545	91	135	309	680	636

**ROV chain block with hot stab**

Product Code	Dimensions (mm)									
	A	B	C	D	E	F1	F2	G	H	M
RCB-030H	374	84	550	420	280	36	56	273	420	458
RCB-060H	374	84	703	354	346	49	70	273	482	
RCB-080H	374	84	749	320	380	51	78	273	503	
RCB-100H	374	84	660	300	400	54	87	273	530	458
RCB-150H	374	84	840	225	510	59	81	273	570	458
RCB-200H	374	90	1050	200	500	81	110	273	700	464
RCB-300H	485	220	1200	388	495	91	135	273	695	

**ROV chain block with QD drive**

Product Code	Dimensions (mm)									
	A	B	C	D	E	F1	F2	G	H	M
RCB-030H-QD	374	84	550	228	280	36	56	273	420	458
RCB-060H-QD	374	84	703	162	346	49	70	273	481	
RCB-080H-QD	374	84	749	162	380	51	78	273	503	
RCB-100H-QD	374	84	660	153	400	54	87	273	530	458
RCB-150H-QD	374	84	840	225	510	59	81	273	570	458
RCB-200H-QD	374	90	1050	148	500	81	110	273	700	458
RCB-300H-QD	485	220	1200	388	515	91	135	273	695	

For SS20 chain block information please see pages 30-33

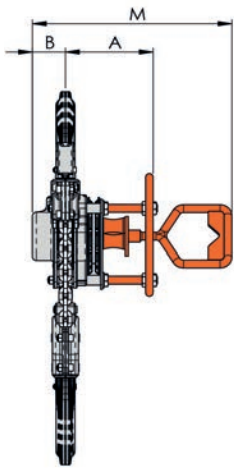

10t D handle

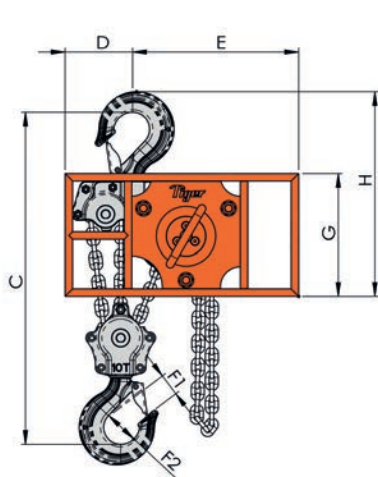

10t fishtail

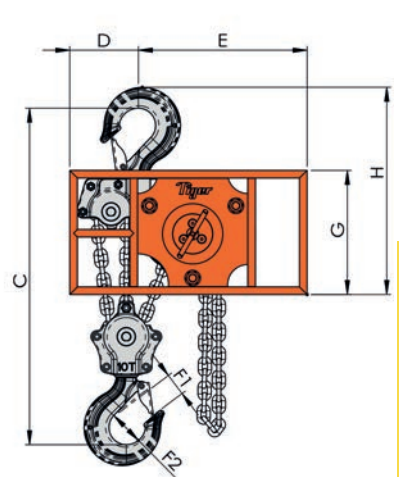

10t rotary torque

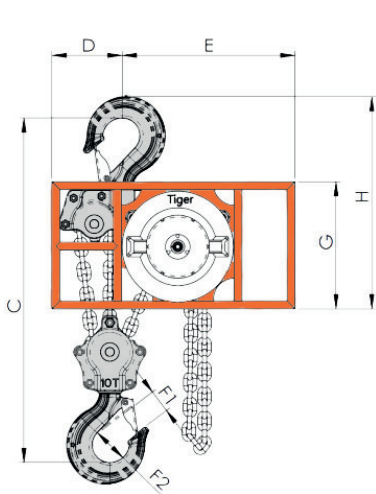

10t hot stab

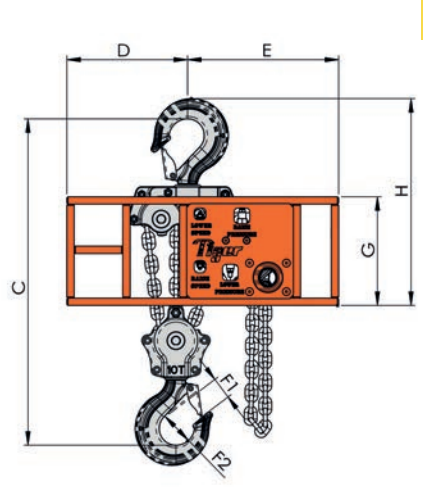

10t QD drive

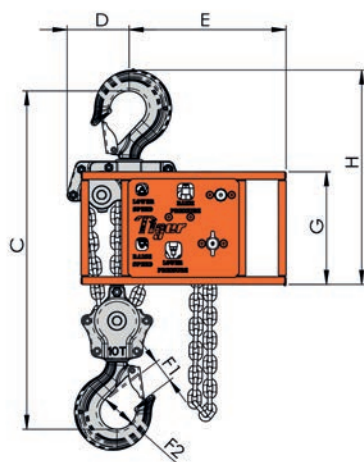
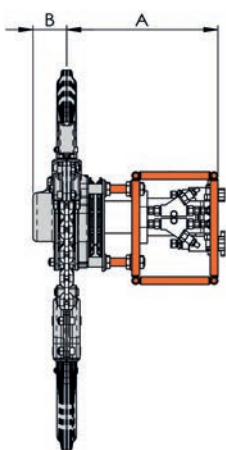

Information, technical and 3D drawings available on request



# Power PRO hoist ETCB



The Tiger Power PRO hoist with load limiter - ETCB, is available in 3.0 tonne, 6.0 tonne and 10.0 tonne capacities. The hoist is fitted with a slipping clutch overload mechanism so it is protected from overload. It is cordless battery powered and suggested to use a drill of maximum 2500 rpm to operate the unit.

- Cordless battery powered
- Available in 3t, 6t & 10t capacities
- High speed helical gear box
- Load limiter



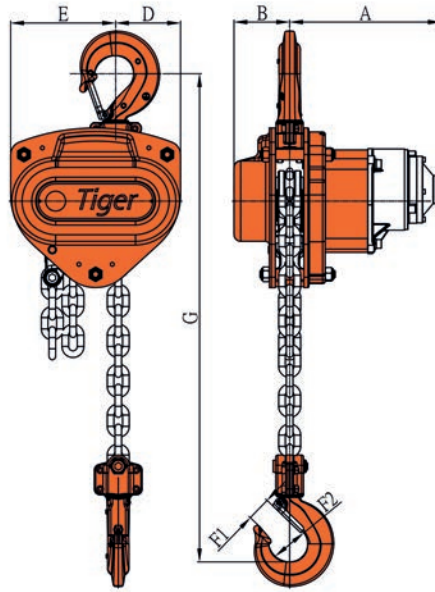

3t

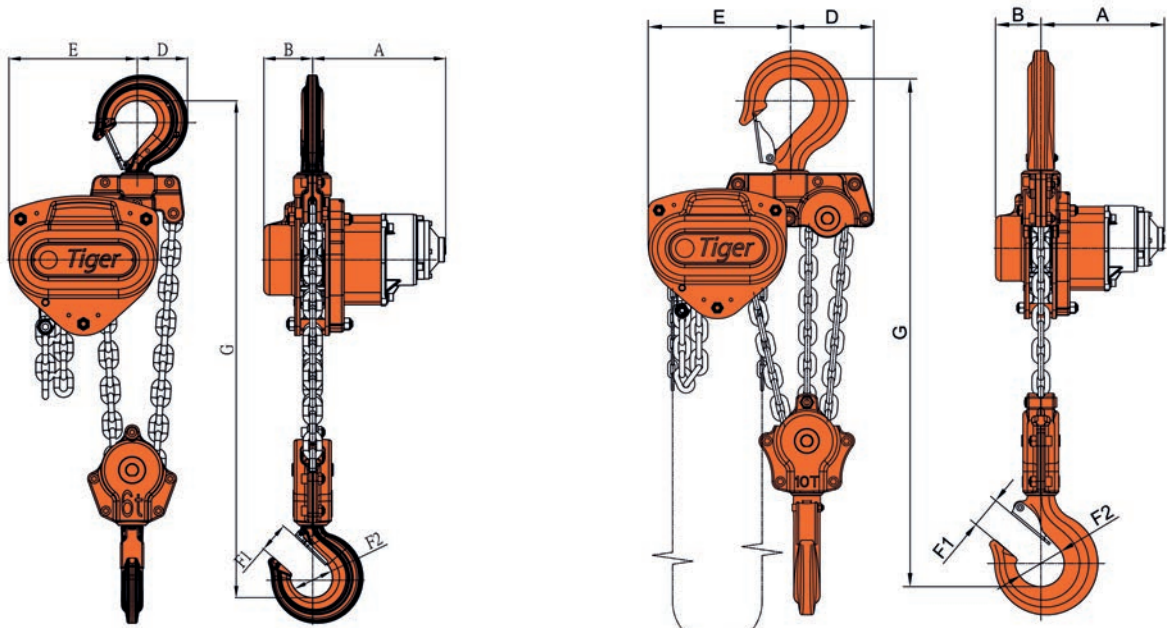

6t

10t

Product Code	Rated load (kg)	Lifting chain specifications (mm)	Dimensions (mm)							No. chain falls	Motor speed (MAX) (r/min)	Lifting speed (m/min)	Brushless drill driver (N.m) V	Net weight (kg)	Packing weight (kg)	Packing size (cm)	Weight for each additional meter of chain (kg/cm)
			A	B	D	E	F1	F2	G								
ETCB-0300	3000	10 x 30	228	84	98	157	36	56	500	1	2600	0.718	68 18V or above	29.6	31.3	38 x 34.5 x 29	2.2
ETCB-0600	6000	10 x 30	228	84	86	220	49	70	635	2	2600	0.359	68 18V or above	44.0	46.4	50 x 37 x 33	4.4
ETCB-1000	10000	10 x 30	228	84	153	263	54	87	660	3	2600	0.239	90 18V or above	56.9	60.8	50 x 43.5 x 41	6.5

# Low headroom combination chain block and trolley



Corrosion or spark resistant versions available.



- Very low headroom
- Range from 1.0t to 10.0t
- Ideal for locations where headroom is limited
- Operating temperature of -40°C to +80°C (temperature range of -60°C to +80°C available as an option)
- Can be chained to any height of lift to meet your exact requirements
- Powder coated universal wheels suit both tapered and flat flange beams
- Chain carrier available
- Corrosion or spark resistant versions available
- Available with load limiter
- Available with beam locking device

## Certification:

Each unit comes fully certified with a test certificate or an EC Declaration of Conformity stating compliance with the essential health and safety requirements of the Machinery Directive 2006/42/EC.

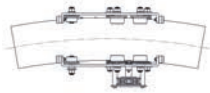
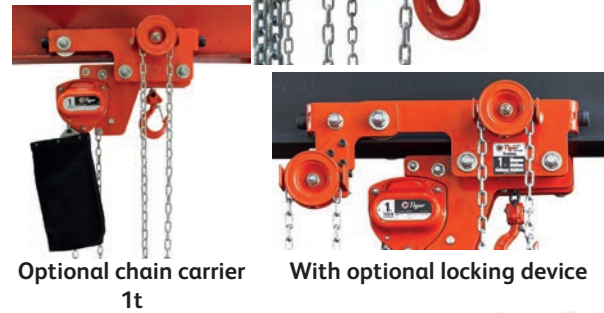

Standard product



With locking device- outside of curve



With locking device- inside of curve

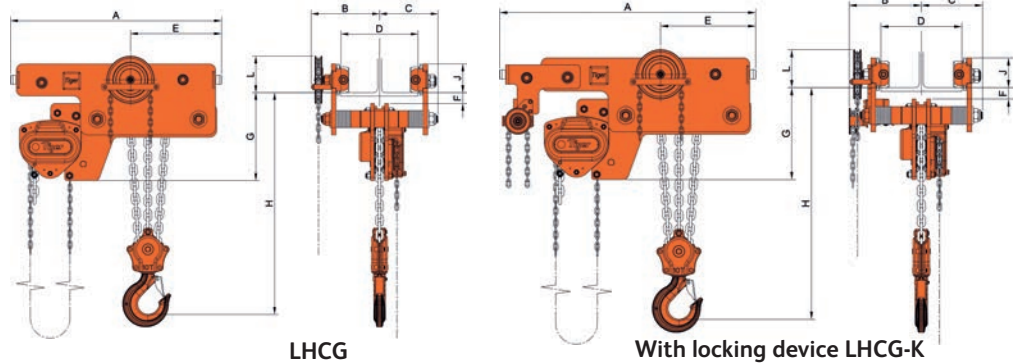

## Technical data

Product Code	Capacity (tonne)	D-Track width		Dimensions (mm)									Min. Curve Radius (m)	Net Weight (kg) @ std HOL range 1/range 2
		Range 1 (mm)	Range 2 (mm)	A	B	C	E	F	G	H	J	L		
LHCG-0100	1.0	62-180	62-310	458	207	138	149	24	230	210	70.5	82	2.2	36.5/38.1
LHCG-0200	2.0	88-180	88-310	576	207	141	179	24	299	260	79.5	94	3.2	62.6/64.4
LHCG-0300	3.0	88-180	88-310	698	209	153	221	32	341	305	96.5	126	4.0	95.2/97.7
LHCG-0600	6.0	106-194	106-310	791	216	164	274	32	344	425	117	137	6.0	132.1/133.7
LHCG-1000	10.0	106-320	N/A	873	283	243	377	45	364	550	118	151	9.0	203.0

## Technical data - with optional locking device

Product Code	Capacity (tonne)	D-Track width		Dimensions (mm)									Min. Curve Radius (m) Locking at the outside of I Beam	Min. Curve Radius (m) Locking at the inside of I Beam	Net Weight (kg) @ std HOL range 1/ range 2
		Range 1 (mm)	Range 2 (mm)	A	B	C	E	F	G	H	J	L			
LHCG-0100-K	1.0	62-180	62-310	572	207	138	149	24	230	210	70.5	82	2.2	3.0	44.2/45.8
LHCG-0200-K	2.0	88-180	88-310	678	207	141	179	24	299	260	79.5	94	3.2	4.5	70.9/72.7
LHCG-0300-K	3.0	88-180	88-310	814	209	153	221	32	341	305	96.5	126	4.0	5.5	105.4/107.9
LHCG-0600-K	6.0	106-194	106-310	924	216	164	274	32	344	425	117	137	6.0	8.0	143.4/145.0
LHCG-1000-K	10.0	106-320	N/A	1013	286	243	377	45	364	550	118	151	9.0	14.0	216.2

Standard geared trolley hand chain length -2.5m. We can change the length to suit your requirements.

Standard height of lift (HOL) of chain block - 3m. We can change this to suit your requirements.

D is the standard track width range. Allow 5mm gap between the wheel flange and beam. Please contact us for track widths outside of this range.

F is the maximum beam flange thickness.



# Ultra low headroom combination chain block and trolley

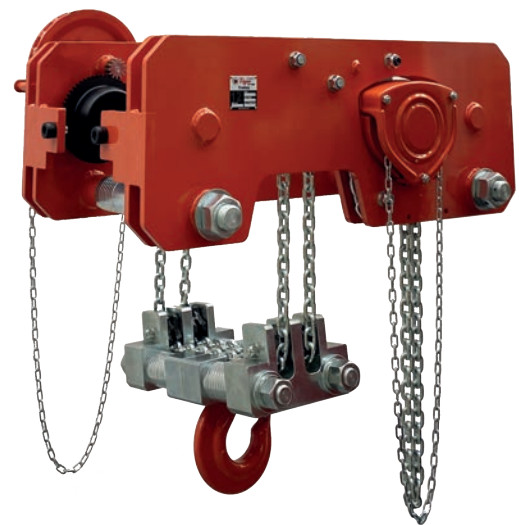

MANUAL HOISTING

- Ultra low headroom
- Range from 1.0t to 12.0t
- Ideal for locations where headroom is limited
- Operating temperature of -40°C to 80°C (temperature range of -60°C to +80°C available as an option)
- Can be chained to any height of lift to meet your exact requirements
- Chain carrier available
- Corrosion or spark resistant versions available
- Powder coated universal wheels suit both tapered and flat flange beams

### Certification:

Each unit comes fully certified with a test certificate or an EC Declaration of Conformity stating compliance with the essential health and safety requirements of the Machinery Directive 2006/42/EC

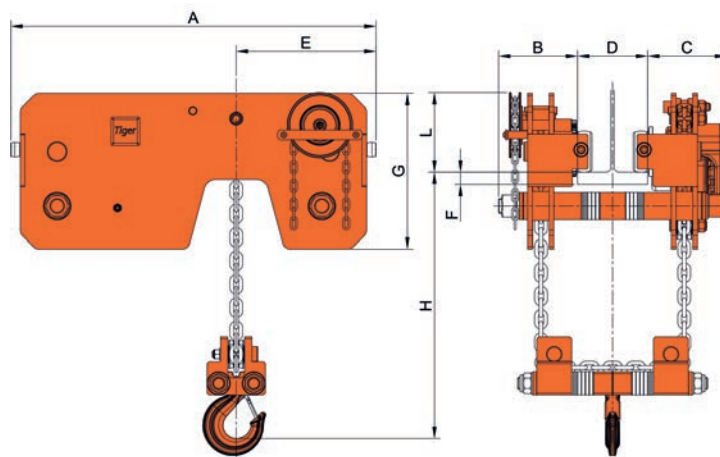

Product Code	Capacity (tonne)	D-Track width (mm)			Dimensions (mm)								Load Chain		Min. Curve Radius (m)	Net Weight (kg) @ std HOL range 1/range 2	Weight for extra metre HOL (kg)
		Range 1	Range 2	Fixed Range	A	B	C	E	F	G	H	L	Diameter (mm)	No. of falls			
ULHCG-0100	1.0	62-180	180-310	62-310	585	161	168	220	26	240	141	126	6.3	2	4	70/73	2.6
ULHCG-0200	2.0	74-180	180-310	74-310	680	161	168	260	31	270	167	140	6.3	2	5	106/114	2.6
ULHCG-0300	3.0	80-180	180-310	80-310	798	175	184	314	36	300	191	178	7.1	2	5	155/158	3.1
ULHCG-0600	6.0	96-180	180-310	96-310	938	205	205	359	41	400	241	205	10	2	8	259/273	5.3
ULHCG-0800	8.0	145-310	-	145-310	1028	230	203	384	31	360	265	317	8	4	6	387	6.6
ULHCG-1200	12.0	145-310	-	145-310	1128	231	219	438	45	420	295	349	10	4	8	519	9.6
ULHCG-1600	16.00	-	-	180-310	1194	235	211	734	45	420	360	268	10	6	8	528	14

The beam width D is customised to customer requirements. Please contact us for more information.

# Combination chain block and trolley



Corrosion or spark resistant versions available.

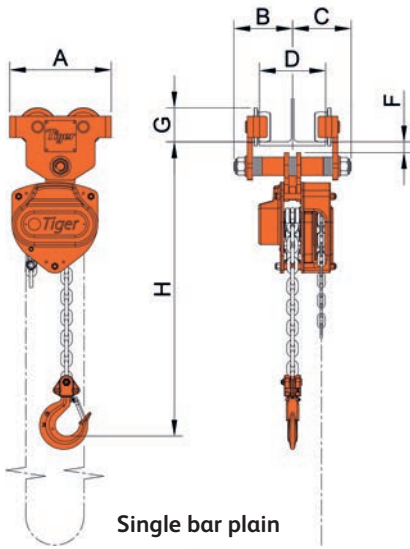

Single bar plain

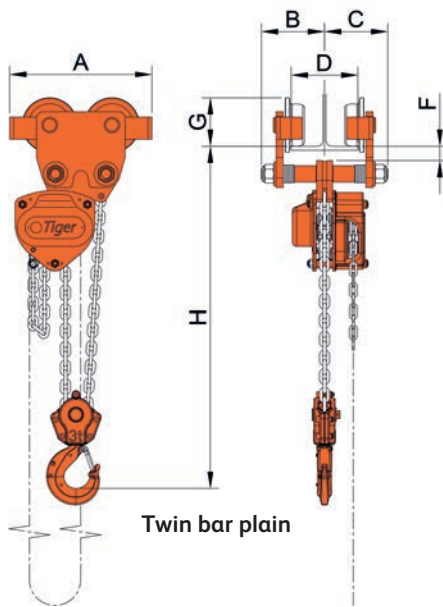

Twin bar plain



Spark resistant version

- Range from 500kg to 35.0t
- Ideal for locations where headroom is limited
- Geared and plain trolley versions available
- Can be chained up to meet your specific requirements
- Twin bar or single bar trolley options
- Corrosion or spark resistant versions available
- Chain Carrier available
- Extended beam width available

## Plain/Push combination units

	Product Code	Capacity (tonne)	D-Track width				Dimensions (mm)						Min. Curve Radius (m)	Net Weight (kg) @ std HOL
			Range 1 (mm)	Range 2 (mm)	Range 3 (mm)	Minimum Range 1 & Range 2 with optional locking device (mm)	A	B	C	H	F	G		
Single Bar Trolleys	CCBTPS-0050	0.5	80-128	80-203	158-310	90	195	106	106	310	20	64	0.8	16.0
	CCBTPS-0100	1.0	80-128	80-203	160-310	90	213	113	113	340	20	71	1.0	19.5
	CCBTPS-0200	2.0	112-154	112-230	218-310	125	236	136	136	420	25	80	1.3	33.0
	CCBTPS-0300	3.0	111-153	111-230	217-310	111	275	146	146	504	25	97	1.5	48.5
Twin Bar Trolleys	CCBTPT-030T	3.0	105-153	105-230	207-310	-	320	142	142	460	30	110	1.5	45.5
	CCBTPT-0500	5.0	126-194	126-310	-	-	352	167	166	545	28	131	1.5	69.0
	CCBTPT-0600	6.0	126-194	-	-	-	352	167	166	587	28	131	2.0	86.0
	CCBTPT-1000	10.0	125-320	-	-	230	394	243	243	660	40	117	1.5	137.0
	CCBTPT-1500	15.0	150-320	-	-	150	509	276	276	827	42	182	2.7	274.0

Standard height of lift (HOL) of chain block - 3m. We can change this to suit your requirements.

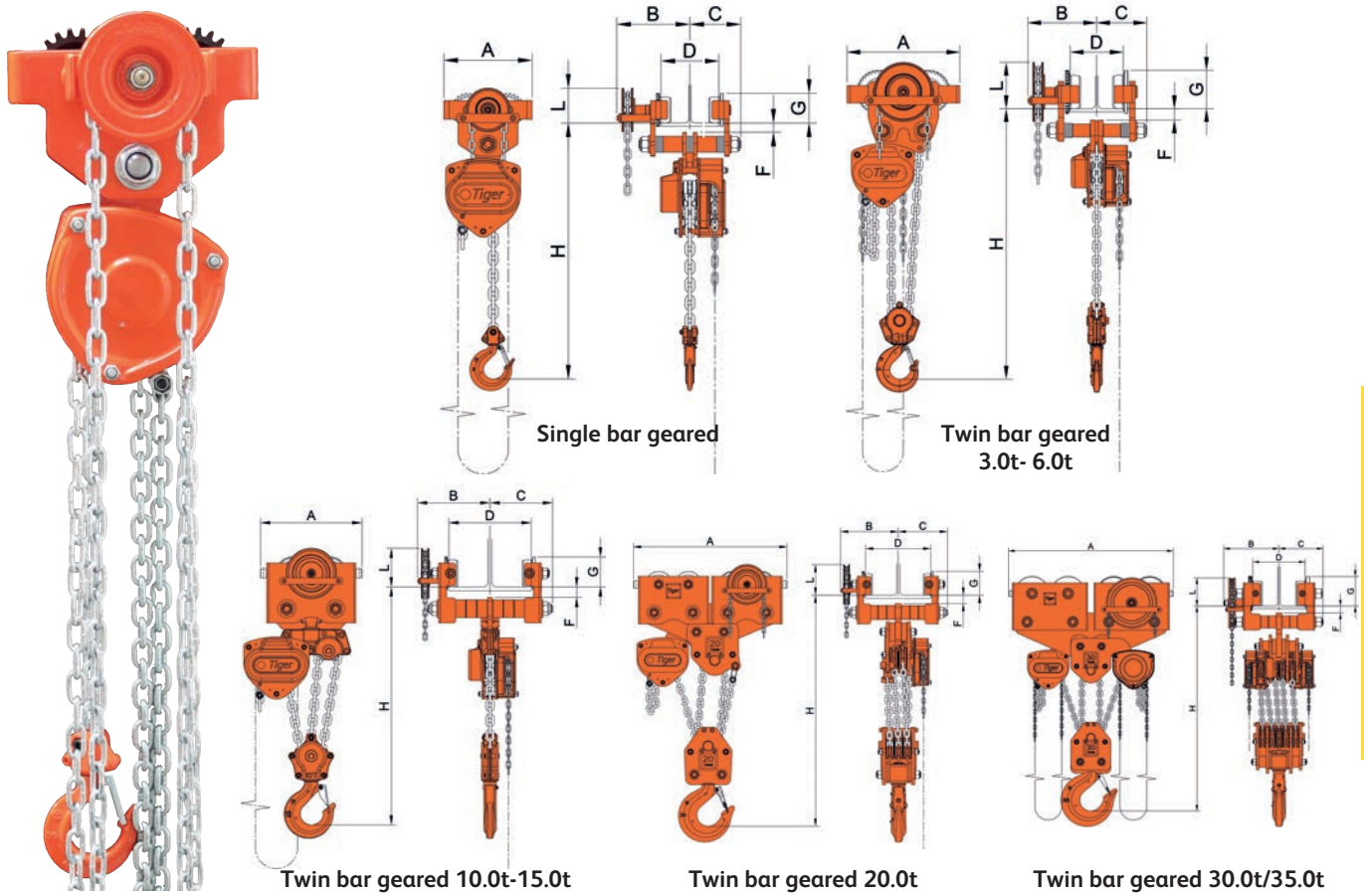

**Geared trolley combination units**

	Product Code	Capacity (tonne)	D-Track width				Dimensions (mm)							Min. Curve Radius (m)	Net Weight (kg) @ std HOL
			Range 1 (mm)	Range 2 (mm)	Range 3 (mm)	Minimum Range 1 & Range 2 with optional locking device (mm)	A	B	C	H	F	G	L		
Single Bar Trolleys	CCBTGS-0050	0.5	80-128	80-203	158-310	90	195	180	106	310	20	64	79	0.8	20.0
	CCBTGS-0100	1.0	80-128	80-203	160-310	90	213	180	113	340	20	71	82	1.0	23.5
	CCBTGS-0200	2.0	112-154	112-230	218-310	125	236	195	136	420	25	80	94	1.3	37.5
	CCBTGS-0300	3.0	111-153	111-230	217-310	111	275	198	146	504	25	97	126	1.5	53.5
Twin Bar Trolleys	CCBTGT-030T	3.0	105-153	105-230	207-310	-	320	194	142	460	30	110	132	1.5	58.5
	CCBTGT-0500	5.0	126-194	126-310	-	-	352	218	166	545	28	131	143	1.5	74.5
	CCBTGT-0600	6.0	126-194	-	-	-	352	218	166	587	28	131	143	2.0	93.0
	CCBTGT-1000	10.0	125-320	-	-	230	394	282	243	660	40	117	119	1.5	144.0
	CCBTGT-1500	15.0	150-320	-	-	150	509	342	276	827	42	182	174	2.7	290.0
	CCBTGT-2000	20.0	125-320	-	-	190	754	284	243	950	40	117	119	6.0	321.0
	CCBTGT-3000	30.0	150-320	-	-	155	1009	339	270	1145	42	182	174	6.0	621.0
CCBTGT-3500	35.0	150-320	-	-	165	1009	335	274	1145	32	182	174	6.0	651.0	

Standard geared trolley hand chain length - 2.5m. We can change the length to suit your requirements.  
 Standard height of lift (HOL) of chain block - 3m. We can change this to suit your requirements.



# Adjustable trolley



## Plain APT

Our high quality, heavy-duty, easy to adjust trolleys allow you to suspend a lifting appliance or load and easily transport it along the length of a beam.

If you need a wider beam range or have specific head room requirements please contact us for bespoke solutions.

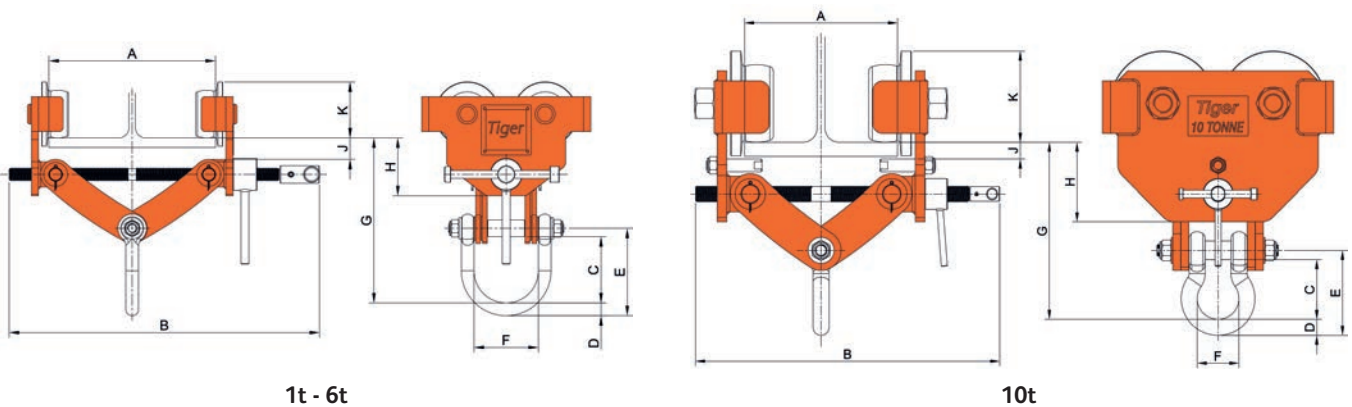

1t - 6t

10t

- Fitted with a screw spindle which allows easy adjustment and high clamping force to the various flange sizes within its capacity
- Designed to provide smooth and easy traversing
- The anti-drop plates design ensures extra safety and prevents damage to the wheels when contacting end rail stoppers
- Wheels run on sealed ball bearings for smoother rolling with less effort and maintenance
- Range from 1.0t to 10.0t
- Operating temperature of -40°C to +80°C (temperature range of -60°C to +80°C available as an option)
- The 5:1 factor of safety allows for use with manual or powered hoists
- These units meet and exceed all the requirements within BS EN 13157: 2004+A1:2009 and AS1418.2.

Product Code	Type	Capacity (tonne)	Track width range (mm)	Dimensions (mm)									Min. Curve Radius (m)	Net Weight (kg)
				A	B	C	D	E	F	G	H	J		
APT-0100	Plain	1.0	75-210	391	83	16	110	81	255-208	73	27	71	1.0	9.5
APT-0200	Plain	2.0	75-210	391	94	18	123	89	276-227	79	38	80	1.3	13.5
APT-0300	Plain	3.0	75-210	403	105	22	141	112	288-241	99	35	97	1.5	23.0
APT-0600	Plain	6.0	105-305	521	111	27	151	125	358-290	115	46	117	1.5	35.5
APT-1000	Plain	10.0	160-305	606	119	32	170	83	407-352	157	33	182	2.7	110.0

# Adjustable trolley



## Geared AGT

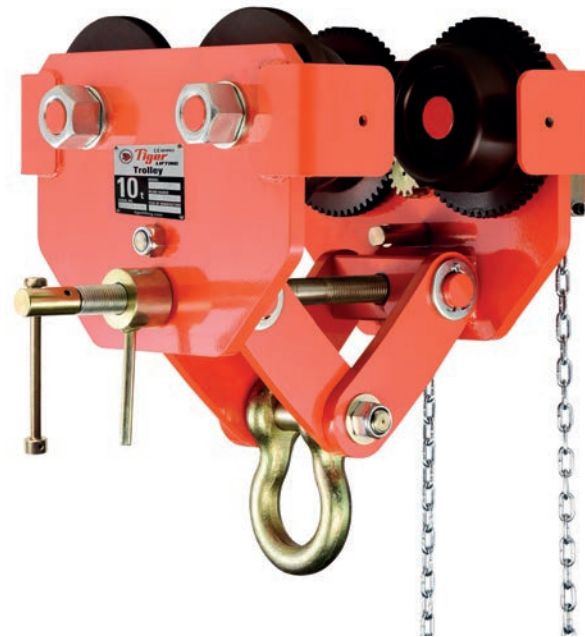

MANUAL HOISTING

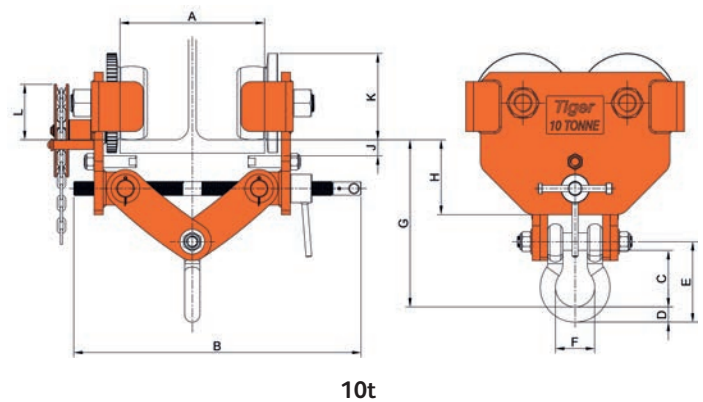
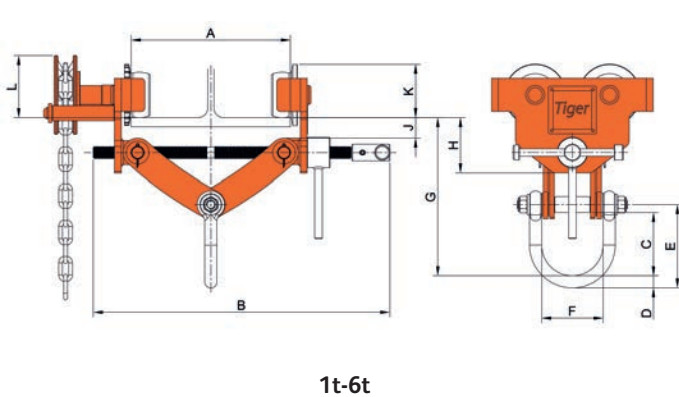

Product Code	Type	Capacity (tonne)	Track width range (mm)		Dimensions (mm)									Min. Curve Radius (m)	Net Weight (kg)
			A	B	C	D	E	F	G	H	J	K	L		
AGT-0100	Geared	1.0	75-210	391	83	16	110	81	255-208	73	27	71	82	1.0	13.0
AGT-0200	Geared	2.0	75-210	391	94	18	123	89	276-227	79	38	80	94	1.3	17.0
AGT-0300	Geared	3.0	75-210	403	105	22	141	112	288-241	99	35	97	126	1.5	28.5
AGT-0600	Geared	6.0	105-305	521	111	27	151	125	358-290	115	46	117	137	1.5	40.0
AGT-1000	Geared	10.0	160-305	606	119	32	170	83	407-352	157	33	182	117	2.7	120.0

Standard geared trolley hand chain length - 2.5m. We can change the length to suit your requirements.

If you need a wider beam range or have specific head room requirements please contact us for bespoke solutions.

# Trolley TP/TG



Corrosion or spark resistant versions available.



- Plain trolley range from 500kg to 10.0t
- Geared trolley range from 500kg to 35.0t
- The anti-drop plates design ensures extra safety and prevents damage to the wheels when contacting end rail stoppers
- Extended beam width available
- Corrosion or spark resistant versions available
- Tiger trolley wheels are specially designed with a convex profile eliminating potential point loading
- The wheels run on sealed ball bearings for smoother rolling with less effort and maintenance
- Operating temperature of -40°C to +80°C (temperature range of -60°C to +80°C available as an option)
- Optional beam locking device
- The 5:1 factor of safety allows for use with manual or powered hoists.



## Plain trolley

### Single bar

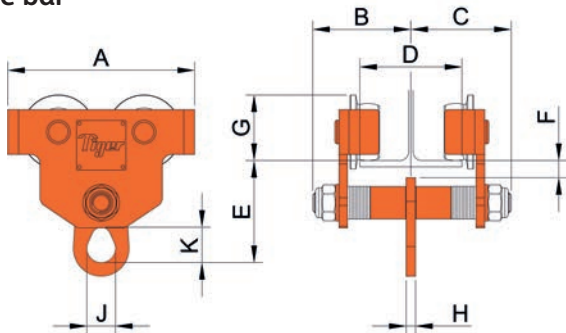

### Twin bar

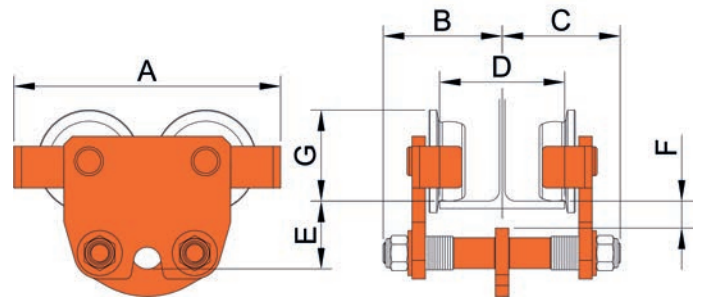

	Product Code	Capacity (tonne)	D-Track width #			Dimensions (mm)										Min. Curve Radius (m)	Net Weight (kg)
			Range 1 (mm)	Range 2 (mm)	Range 3 (mm)	A	A+	B	C	E	F	G	H	J	K		
Single Bar Trolleys	TPS-0050	0.5	62-128	62-203	140-310	195	235	106	106	98	20	64	10	24	30	0.8	5.0
	TPS-0100	1.0	62-128	62-203	142-310	213	253	113	113	106	20	71	10	27	34	1.0	7.5
	TPS-0200	2.0	88-154	88-230	194-310	236	284	136	136	132	25	80	13	38	45	1.3	12.0
	TPS-0300	3.0	87-153	87-230	193-310	275	323	146	146	150	25	97	13	42	53	1.5	19.5
	TPS-0500	5.0	106-194	106-310	-	323	371	169	169	174	30	117	16	46	59	1.5	30.5
Twin Bar Trolleys*	TPT-0300	3.0	87-153	87-230	189-310	320	368	142	142	82	30	110	-	-	-	1.5	22.0
	TPT-0500	5.0	106-194	106-310	-	352	400	167	166	91	30	131	-	-	-	1.5	35.5
	TPT-0600	6.0	106-194	-	-	352	400	167	166	91	32	131	-	-	-	1.5	37.5
	TPT-1000	10.0	125-320	-	-	-	394	243	243	210	40	117	-	-	-	1.5	68.0
	TPT-1500+	15.0	150-320	-	-	-	509	271	271	248	42‡	182	-	-	-	2.7	144.0

### Technical data - with optional locking device - dimensions as above

	Product Code	Capacity (tonne)	D-Track width #	
			Range 1 (mm)	Range 2 (mm)
Single Bar Trolleys	TPS-0050	0.5	95-128	95-203
	TPS-0100	1.0	100-128	100-203
	TPS-0200	2.0	110-154	110-230
	TPS-0300	3.0	90-153	90-230
	TPS-0500	5.0	106-194	106-305
Twin Bar Trolleys*	TPT-1000	10.0	180-320	-
	TPT-1500+	15.0	150-320	-

If you need a wider beam range or have specific head room requirements please contact us for bespoke solutions.

Notes:  
 3t twin bar and 5t twin bar options are not available with optional locking device  
**A+** is the width with optional bumpers **B** and **C** are minimum widths for range 1  
**H** is the thickness of the anchor point, **J** is the width of the anchor point opening and **K** is the height of the anchor point opening.  
 \* 0.5t-2t twin bar available as special orders – minimum order 100 each size – please contact us for details.  
 † We are currently changing the design of our 10t and 15t trolleys. The dimensions shown are for the new type. Please contact us for details of which types are available.  
 ‡ A beam flange thickness up to 50mm can be accommodated if required – please ask for more information.  
 # Please contact us for track widths outside of these ranges



# Geared trolley

If you need a wider beam range or have specific head room requirements please contact us for bespoke solutions.

## Single bar

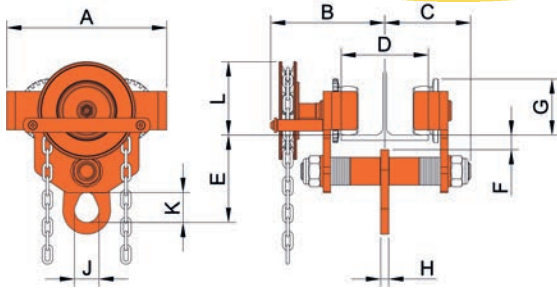

## Twin bar

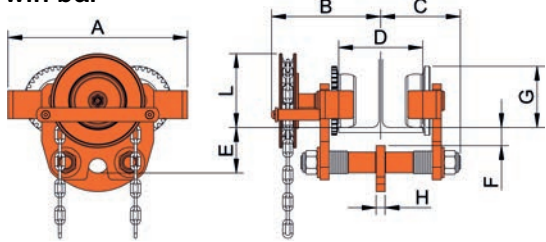

3t-6t

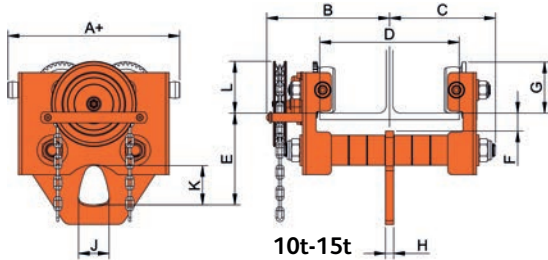

10t-15t

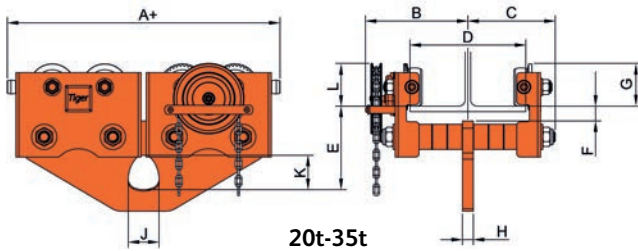

20t-35t



Optional beam locking device

Smaller minimum curve ratios may be available - contact us for details.

MANUAL HOISTING

Technical data - with optional locking device - dimensions as below

	Product Code	Capacity (tonne)	D-Track width #	
			Range 1 (mm)	Range 2 (mm)
Single Bar Trolleys	TGS-0050	0.5	95-128	95-203
	TGS-0100	1.0	100-128	62-203
	TGS-0200	2.0	110-154	110-230
	TGS-0300	3.0	90-153	90-230
	TGS-0500	5.0	106-194	106-305
Twin Bar Trolleys*	TGT-1000	10.0	180-320	-
	TGT-1500+	15.0	150-320	-
	TGT-2000+	20.0	190-320	-
	TGT-3000+	30.0	155-320	-

	Product Code	Capacity (tonne)	D-Track width #			Dimensions (mm)											Min Curve Radius (m)	Net Weight (kg)
			Range 1 (mm)	Range 2 (mm)	Range 3 (mm)	A	A+	B	C	E	F	G	H	J	K	L		
Single Bar Trolleys	TGS-0050	0.5	62-128	62-203	140-310	195	235	180	106	98	20	64	10	24	30	79	0.8	9.0
	TGS-0100	1.0	62-128	62-203	142-310	213	253	180	113	106	20	71	10	28	34	82	1.0	11.0
	TGS-0200	2.0	88-154	88-230	194-310	236	284	195	136	132	25	80	12	38	45	94	1.3	16.5
	TGS-0300	3.0	87-153	87-230	193-310	275	323	198	146	150	25	97	13	42	52	126	1.5	24.5
	TGS-0500	5.0	106-194	106-310	-	323	371	216	169	174	30	117	16	46	60	137	1.5	35.5
Twin Bar Trolleys*	TGT-0300	3.0	87-153	87-230	189-310	320	368	194	142	82	30	110	16	-	-	132	1.5	23.5
	TGT-0500	5.0	106-194	106-310	-	352	400	216	166	91	30	131	19	-	-	143	1.5	40.0
	TGT-0600	6.0	106-194	-	-	352	400	216	166	91	32	131	19	-	-	156	1.5	42.0
	TGT-1000	10.0	125-320	-	-	-	394	282	243	210	40	117	19	70	90	119	1.5	78.0
	TGT-1500+	15.0	150-320	-	-	-	509	338	271	248	42	182	22	75	100	35	2.7	161.0
	TGT-2000+	20.0	125-320	-	-	-	754	282	243	231	40	117	30	85	95	119	6.0	160.0
	TGT-3000+	30.0	150-320	-	-	-	1009	335	274	288	42	182	35	100	115	35	6.0	337.0
TGT-3500+	35.0	150-320	-	-	-	1009	335	274	288	42	182	38	100	115	35	6.0	341.0	

See left for notes

# Industrial screw trolley SPT/SGT



- Range from 500kg to 5.0t
- The wheels run on sealed bearings for smoother rolling with less effort and maintenance
- Geared type with hand chain length to suit your requirements
- The 4:1 factor of safety allows for use with manual or powered hoists
- The anti-drop plates design ensures extra safety, and also prevents damage to the wheels when contacting end rail stoppers

Each unit comes fully certified with a test certificate or an EC Declaration of Conformity stating compliance with the essential health and safety requirements of the Machinery Directive 2006/42/EC.

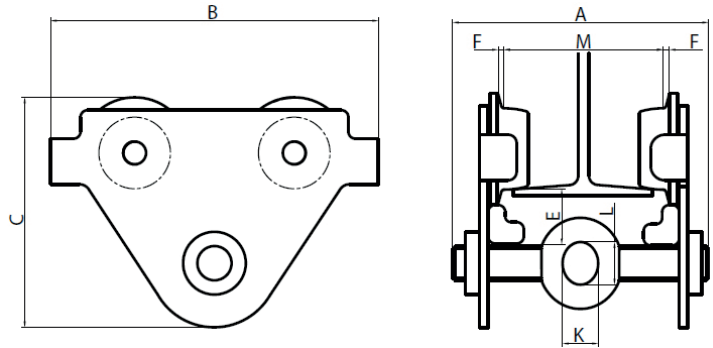

## Screw push trolley

Product Code	Capacity (tonne)	Dimensions (mm)								Net Weight (kg)
		Beam Range M	A	B	C	E	F	K	L	
SPT-0050	0.5	50-220	300	210	190	33	3	25	30	7.0
SPT-0100	1.0	64-220	300	260	211	31	3	30	35	10.0
SPT-0200	2.0	88-220	310	310	236	32	3	40	47	15.5
SPT-0300	3.0	102-220	320	390	295	46	3	48	58	26.0
SPT-0500	5.0	114-220	330	450	334	47	3	60	70	38.0

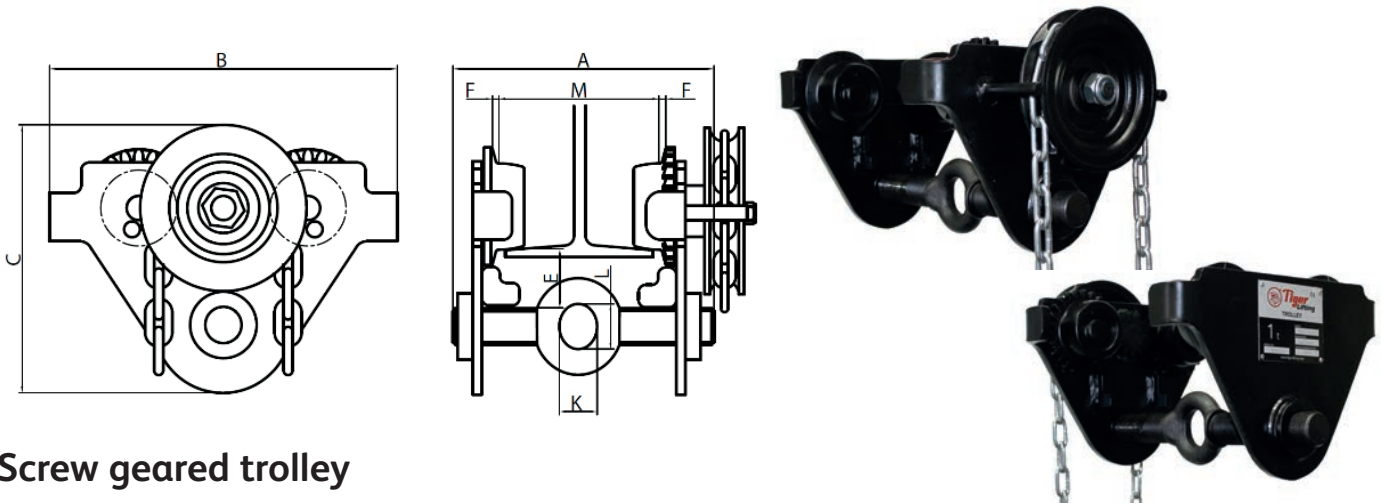

## Screw geared trolley

Product Code	Capacity (tonne)	Dimensions (mm)								Net Weight (kg)
		Beam Range M	A	B	C	E	F	K	L	
SGT-0050	0.5	50-220	300	210	190	33	3	25	30	9.0
SGT-0100	1.0	64-220	300	260	211	31	3	30	35	13.0
SGT-0200	2.0	88-220	310	310	236	32	3	40	47	20.5
SGT-0300	3.0	102-220	320	390	295	46	3	48	58	30.0
SGT-0500	5.0	114-220	330	450	334	47	3	60	70	45.0

# Spark resistant trolley



Ex II 2 GD c IIC T4 IIIC T135°

In many areas of industry, plants are operated with potentially explosive atmospheres. Due to the very high risk to personal and other assets, extremely strict guidelines and technical requirements are in place in explosive zones.

Tiger Spark Resistant products are manufactured in accordance with ATEX Directive 2014/34/EU and the Machinery Directive 2006/42/EC.

Our products are lightweight and durable with a proven track record.

Plain and geared trolleys available.

- Range from 500kg to 35.0t
- Solid bronze trolley wheels
- Rubber buffers for trolleys
- Copper plated hand wheel and stainless steel hand chain (geared trolley)
- Copper plated hanging plate
- Special corrosion protected body
- Combination block and trolley units available
- Optional Beam locking device
- Operating temperature -40°C to +80°C (temperature range of -60°C to +80°C available as an option)



MANUAL HOISTING

If you need a wider beam range or have specific head room requirements please contact us for bespoke solutions.

It is the responsibility of the user to identify which explosion proof classification is required, not the hoist manufacturer or supplier.

## Certification:

Under the ATEX Directive 2014/34/EU, equipment for areas with an explosion hazard is assigned to groups, categories and temperature classes. Our products are assigned as follows:

Ex II 2 GD c IIC T4 IIIC T135°C

Suitable for gas and dust hazardous areas: Zone 1 & 2 (gas) and Zone 21 & 22

Dimension data available on pages 40 - 41

### Ex II 2 GD c IIC T4 IIIC T135°C

II	2	GD	c	IIC	T4	IIIC	T135°C		
								<b>T135°C</b>	Dust Temperature Class: Maximum external surface temperature 135°C
								<b>IIIC</b>	Groups of Dust: Protected for group IIIC which includes groups IIIA & IIIB
								<b>T4</b>	Gas Temperature Class: Maximum external surface temperature 135°C
								<b>IIC</b>	Gas Explosion Group: Protected for group IIC which includes groups IIA & IIB
								<b>c</b>	Protection type: Design safety
								<b>GD</b>	Ex Atmosphere: Gas and Dust
								<b>2</b>	Category: High Safety
<b>II</b>	Equipment Group: surface industries								



# Beam anchor



Tiger beam anchors are used as anchorage connectors for personal fall arrest systems. They are designed to be attached to Horizontal I-Beams with an attached personal fall arrest system (full body safety harness, shock absorbing lanyard or fall arrest block). The Tiger single jaw sliding clamp can also be attached to Vertical I-Beams.

Beam Flange Sizes: The Fixed Beam Anchor may only be installed on beams with flanges within the adjustment range of the model.

Capacity: This Fixed Beam Anchor is designed for one person use only, with a combined weight (clothing, tools, etc.) of no more than 310 lbs (140kgs). No more than one personal protective system may be connected to this equipment at one time.

- CE Certified - CE 1019
- Minimum Breaking Strength 22.3kN (5,000lb/2.27tonne)
- Capacity 140kg
- Quick and versatile anchorage point for personal fall protection equipment
- Easy adjustment
- Beam width ranges 2.5" to 24", 6.35cm to 60cm
- Maximum flange thickness 1.5", 3.8cm
- Unit weight from 1.9kg - 3.5kg
- These units meet the requirements of EN 795:2012/B and ANSI/ASSE Z359.1-2007

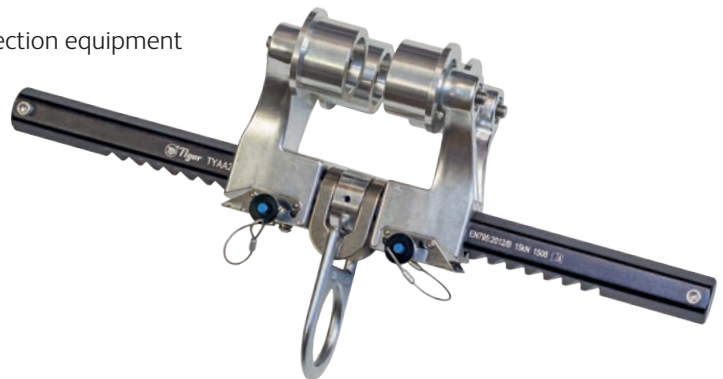

## Rolling type

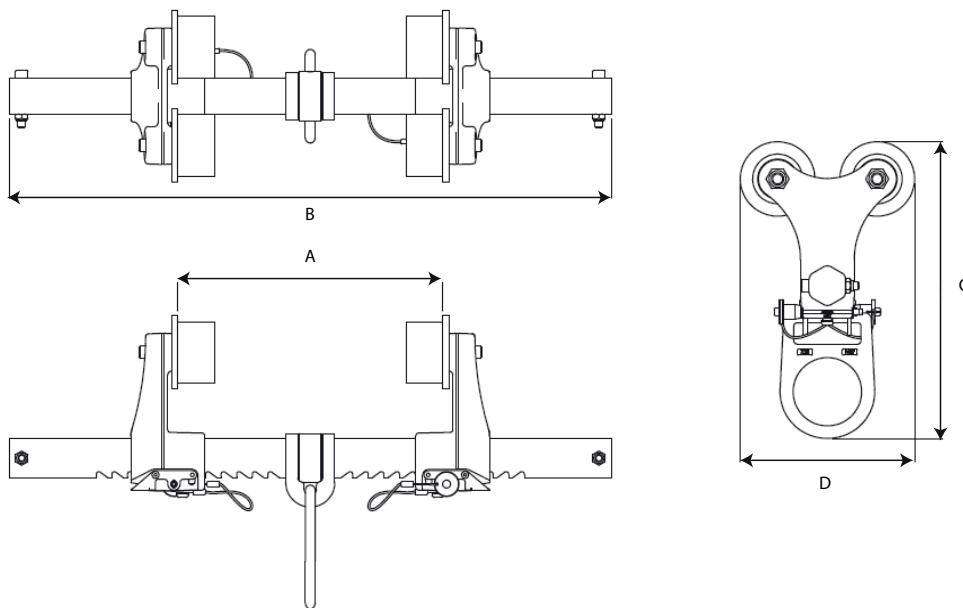

Rolling type two-jaw sliding

Description	Product Code	A-Beam Flange Size	B (mm)	C (mm)	D (mm)	Net Weight (kg)
Mobile (rolling) Type Two-Jaw Sliding Horizontal Beam Use	TYAA231	2.5" to 12" 6.35cm to 30.0cm	490	239	140	3.00
	TYAA232	2.5" to 18" 6.35cm to 45.0cm	643	239	140	3.28
	TYAA233	2.5" to 24" 6.35cm to 60.0cm	790	239	140	3.56

Maximum flange thickness 1.5", 3.8cm

## Fixed type



Fixed type two-jaw sliding

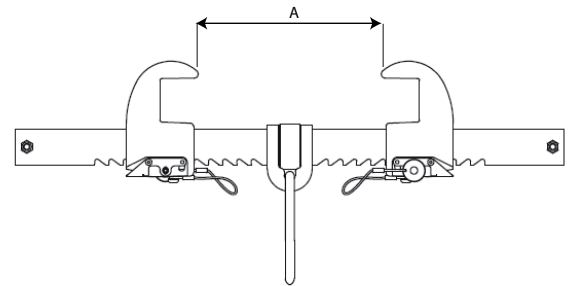
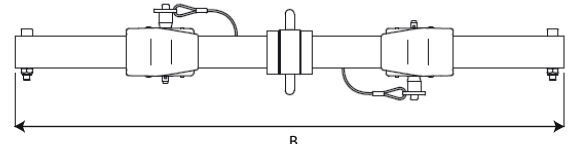
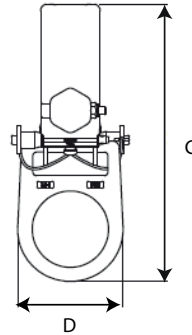

MANUAL HOISTING



Fixed type single-jaw sliding

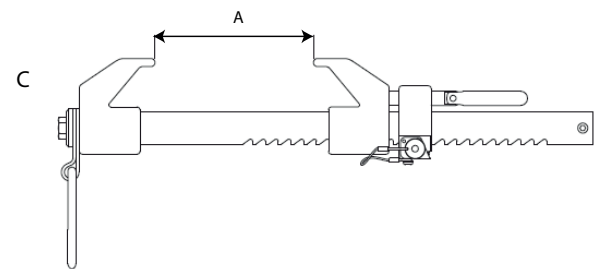
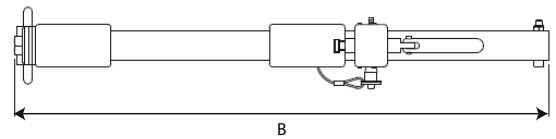
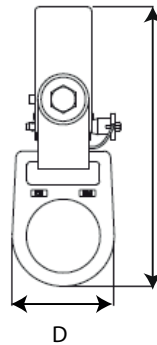

## Fixed type

Description	Product Code	A-Beam Flange Size	B (mm)	C (mm)	D (mm)	Net Weight (kg)
Fixed Type Single-Jaw Sliding Horizontal & Vertical Beam Use	TYAA141	2.5" to 12" 6.35cm to 30.0cm	531	209	76	2.54
	TYAA142	2.5" to 18" 6.35cm to 45.0cm	684	209	76	2.83
	TYAA143	2.5" to 24" 6.35cm to 60.0cm	781	209	76	3.12
Fixed Type Two-Jaw Sliding Horizontal Beam Use	TYAA211	2.5" to 12" 6.35cm to 30.0cm	490	199	76	1.93
	TYAA212	2.5" to 18" 6.35cm to 45.0cm	643	199	76	2.22
	TYAA213	2.5" to 24" 6.35cm to 60.0cm	790	199	76	2.51

Maximum flange thickness 1.5", 3.8cm

# Wire rope puller



The manual wire rope puller is a hand operated lifting and pulling device. The puller could also be used for lowering, tensioning and guying which makes it a versatile, portable and multipurpose tool.

The principle function of the wire puller is that the rope passes through mechanical jaws rather than being reeled on a drum of a puller or conventional winch.

The tension of the rope is applied by means of two pairs of self-energised jaws which apply a grip onto the wire rope in sections.

The effort is transferred to the jaws by two parallel levers, one for forward operation and the other for reverse operation. A telescopic bar, fitted to either the forward or reverse lever, transmits the effort to the jaw mechanism.

This parallel clamping system provides an evenly distributed grip at a lower force, resulting in less rope wear. The load is held securely at all times.

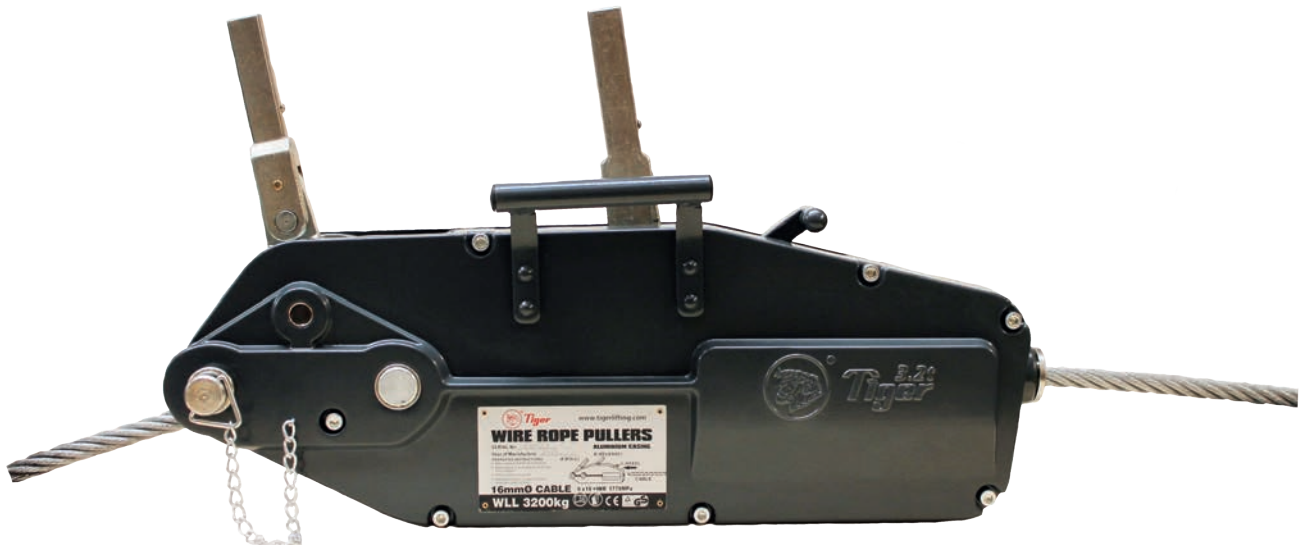

TRPA (Aluminium)

- Range from 800kg to 5400kg (Lifting Capacity)
- Lightweight manual pulling machines - simple and safe to operate
- Corrosion free aluminium alloy casing
- Rope clamp system easily disengaged with a lever allowing smooth installation of wire rope
- Individually serial numbered for traceability
- Usable at horizontal, vertical and angled working positions
- Equipped with an anchor bolt offering numerous connection possibilities
- Supplied with relevant certification and user instructions
- Compact high-strength
- 20m steel wire with eye hook as standard
- Overload protection built in, with a shearing pin in the forward lever
- Shear pins can be replaced without removing the load
- Spare shear pins supplied
- Parallel clamping system providing evenly distributed grip at a lower force, resulting in less rope wear



Tiger wire rope pulling machines are suitable for pulling, lifting, tensioning and releasing in any direction.

They are available in light and compact aluminium or pressed steel construction for applications where aluminium is not recommended.

The wire rope puller comes with a telescopic operating handle\* and 20 metres of wire rope fitted with an eye-type hook as standard. Any length of rope can be supplied to your requirements. Alternatively the wire rope puller is available as a machine only, without wire rope. (\*the operating handle with the 800kg TRPA/TRPS is not telescopic)

These units meet and exceed all the requirements within BS EN 13157:2004+A1:2009.

Product Code (ALUMINIUM CASING)	WLL (kg)	Pulling Capacity (kg)	Rope Diameter (mm)	Breaking Strain (kN)	Effort (kg)	Advance/Pull (mm)	Net Weight (kg)	Overall Length (mm)	Overall Height (mm)	Overall Width (mm)
TRPA-08	800	1200	8.3	43	35	52	6.0	426	235	64
TRPA-16	1600	2400	11	120	41	55	11.0	545	280	97
TRPA-32	3200	4800	16	162	45	28	22.0	660	325	116
TRPA-54	5400	8000	20	264	76	30	59.0	930	480	152

### Increase the pulling and lifting capacity:

Various methods of rigging are shown. For the correct and incorrect method refer to figures 1 and 2. Other methods of rigging will increase the capacity of the machine – refer to figures 3 and 4.

In examples 3 and 4 the maximum working load limit (WLL) of the pulley and anchor point shall be equal to or greater than two times the WLL.

NOTE: When the wire rope puller is anchored directly to a fixed point, ensure that there are no obstructions around the machine which could prevent the wire rope, puller and anchor from operating in a straight line.

It is recommended to use a sling of similar capacity between the anchor point and the unit.

WARNING: Any rigging configuration which requires the calculation of forces applied should be checked by a competent engineer, with special attention to the strength of the fixed point used.

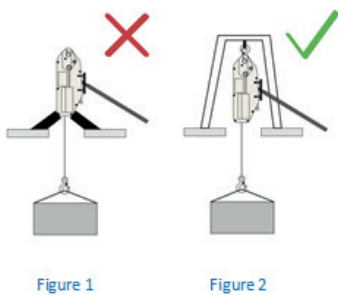

Figure 1

Figure 2

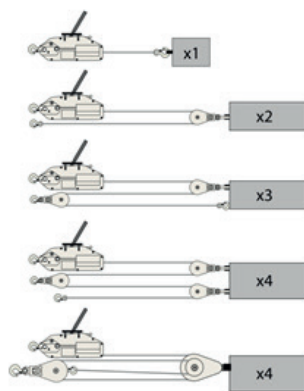

Figure 3

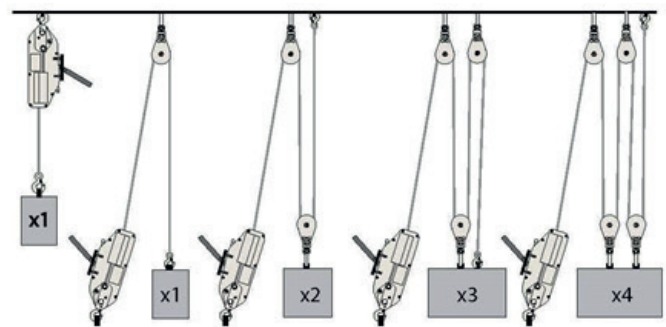

Figure 4

# Webbing puller



Tiger webbing pullers are designed for use in hot line applications. They are lightweight and incorporate a webbing strap and lever handle. When clean and dry, the polyester webbing strap provides insulating properties.

Along with the Fibre Reinforced Plastic (FRP) insulated handle this increases electrical safety when tensioning conductors and similar tasks. It also has a load holding function in both forward and reverse modes which are selected by a single click of the ratchet tab. The handle can rotate 360° to allow the most efficient use of the ratchet at any angle.

Not to be used for lifting. Not to be used for supporting people.



- Capacities 1t- 2t
- When clean and dry the web strap is non-conductive
- Insulated handle
- Handle rotates full 360°
- Automatic brake with notch at a time operation
- Up-Neutral-Down
- Free wheeling
- Lightweight and compact
- Voltage Proof Test 15kV
- 4:1 factor of safety



Product Code	Capacity (tonne)	Strap Size	Lever Length (mm)	Max Length (mm)	Min Length (mm)	Net Weight (kg)
WS-1000	1.0	2 x 33	400	2000	420	3.2
WS-1500	1.5	2.2 x 40	460	2000	420	4.5
WS-2000	2.0	2.2 x 40	460	2000	450	4.5

# Entertainment rigging



MANUAL HOISTING

- A range of Tiger products available in black finish for the entertainment industry
- Chain blocks, lever hoists, beam clamps, trolleys and combination block and trolley units
- Black chain carriers for chain block hand chain available
- Different capacities and heights of lift to suit your specific requirements
- Durable lightweight products
- Proven track record
- See individual product pages for full specifications

Please also see our height safety and winching products for details of other equipment which may be useful for the entertainment industry.



# Universal beam clamp BCU



The Tiger Universal Beam Clamp Model No BCU has been designed not only for vertical use, but also for side load applications, where conventional clamps are not suitable. This clamp is highly flexible in application and can be used for lifting, pulling or as a semi-permanent anchor point.

It can be loaded at any angle and eliminates the use of spreader beams in various lifting operations.

- Suitable for pulling and lifting at angles across the beam
- Designed for both vertical and side loading applications - can be loaded at any angle
- Full rated capacity at any lifting angle

Warning: Do not exceed working load limits or use this equipment for lifting flat plate sections

- 2.0t, 3.0t, 5.0t and 10.0t capacities available
- \*NEW\* 10t deep flange option (to 40mm)
- Quick and versatile rigging point for hoisting equipment
- Low headroom design
- Highly flexible – for lifting, pulling or as a semi-permanent anchor point
- Designed to accommodate a wide range of beam widths
- Multi directional adjusting screw spindle ensures a high clamping force to the beam web
- Operating temperature -40°C to +80°C (temperature range of -60°C to +80°C available as an option)
- Factor of safety: 5:1 for straight pulling and lifting, 4:1 at all other angles
- Complies with ASME B30.20 and EN13155:2003+A2:2009

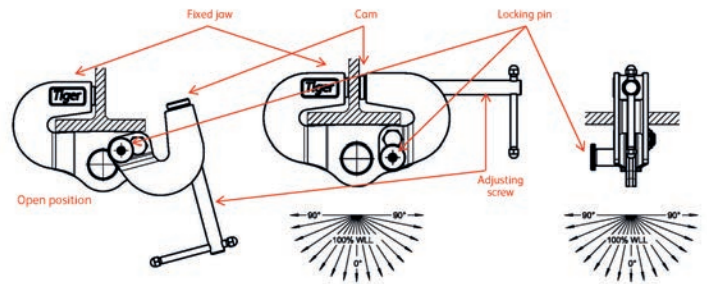
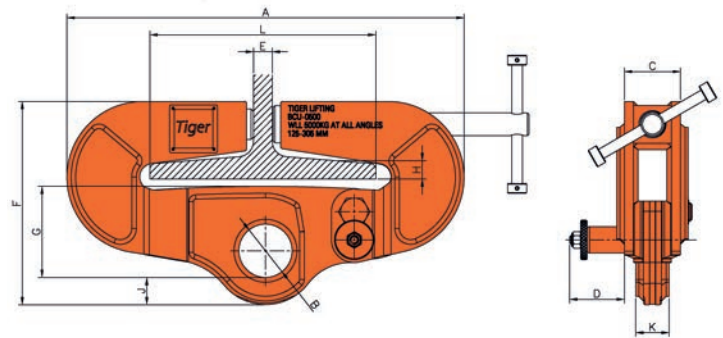

If you need a wider beam range or have specific head room requirements please contact us for bespoke solutions.

Product Code	Capacity (tonne)	Dimensions (mm)											Net Weight (kg)
		A	B	C	D	E	F	G	H	J	K	L	
BCU-0200	2.0	337	58	60	68	32	203	88.5	25.4	22.5	20	76-190	10.0
BCU-0300	3.0	387	60	70	63	32	235	100	25.4	28	20	125-204	15.5
BCU-0500	5.0	524	70	74	72	32	268	120	25.4	36	44	125-305	27.0
BCU-1000	10.0	524	70	76	82	32	278	120	25.4	38	52	125-305	31.0
BCU-100D	10.0	539	76	76	82	47	286	120	40	38	52	125-305	33.0

## Bulb flat bar anchor clamp BCB



The Tiger BCB bulb bar anchor is designed for attaching to bulb profiles of bulb flat bars approved for lifting applications. These are often found in ship compartments, engine rooms and overhead bridge deck structures. The bulb bar anchor provides a quick and versatile, semi-permanent lifting point. The large integrated shackle gives easy connection for all different types of lifting machines.

Each unit comes fully certified with a test certificate or an EC Declaration of Conformity stating compliance with the essential health and safety requirements of the Machinery Directive 2006/42/EC.

Please note that this model must NOT be used for lifting beams. It is a suspension point.



- 1.5t and 3.0t capacities available
- Quick and versatile rigging point for hoisting equipment when attached to bulb flat bars approved for lifting applications
- Shackle suspension point
- No tools required-integrated adjusting screw spindle
- Operating temperature -40°C to +80°C (temperature range of -60°C to +80°C available as an option)
- Up to 45° side loading with no deration
- 15° cross loading with no deration
- Factor of safety: 5:1 for straight pulling and lifting, 4:1 at other angles stated above
- These units meet and exceed all the requirements within BS EN 13155:2003+A2:2009

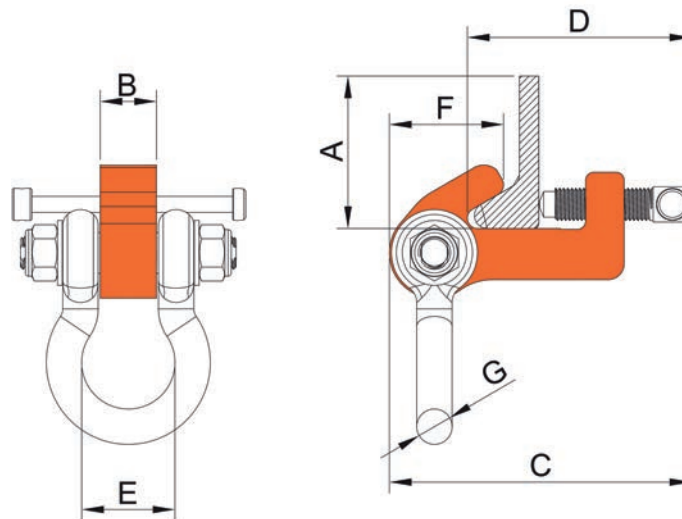

Product Code	Capacity (tonne)	Dimensions (mm)							Net Weight (kg)
		A	B	C	D	E	F	G	
BCB-0150	1.5	160-240	35	173-200	125-151	58	71	22	3.6
BCB-0300	3.0	240-320	42	214-241	155-182	68	94	25	6.4

# Fixed jaw heavy duty beam clamp with shackle BCF



- Range from 1.0t to 30.0t
- \*NEW\* 6.0t and 10.0t models available to suit extra wide flange beams
- Quick and versatile rigging point for hoisting equipment
- Shackle suspension point
- Suitable for pulling and lifting at angles across the beam
- Up to 90° side loading with no deration
- 15° cross loading with no deration
- Highly flexible- for lifting, pulling or as a semi-permanent anchor point
- Evenly distributed loads achieved through maximum jaw surface area
- Multi directional adjusting screw spindle ensures a high clamping force to the various flange sizes within its capacity
- Beam width range 75mm to 457mm
- Optional locking device for 1t -10t (as standard on 15t - 30t)
- Operating temperature -40°C to +80°C (temperature range of -60°C to +80°C available as an option)
- Factor of safety: 5:1 for straight pulling and lifting, 4:1 at other angles stated above
- These units meet and exceed all the requirements within BS EN 13155:2003 + A2:2009 and AS4991

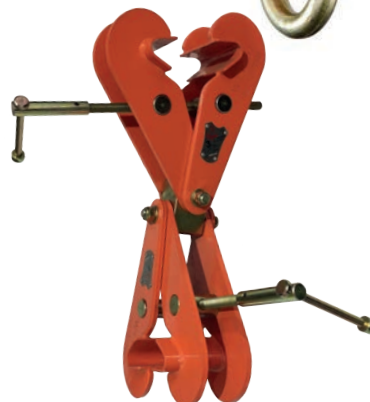

Adjustable double ended clamp also available

No deration up to 90° has been established for Tiger BCF model clamps and applies only for overhead beam attachments. It DOES NOT apply when used for lifting beams.

We advise that structural calculations are carried out on all beams and supporting steel work by qualified engineering departments to ensure safe operation.

# Spark resistant beam clamp



Ex II 2 GD c IIC T4 IIIC T135°

In many areas of industry, plants are operated with potentially explosive atmospheres. Due to the very high risk to personal and other assets, extremely strict guidelines and technical requirements are in place in explosive zones.

Tiger Spark Resistant products are manufactured in accordance with ATEX Directive 2014/34/EU and the Machinery Directive 2006/42/EC.

Suitable for gas and dust hazardous areas: Zone 1 & 2 (gas) and Zone 21 & 22 (dust).

- Copper plated suspension shackle and adjusting bar
- Special corrosion protected coated body
- Optional beam locking device



Available with jaw protection



Certification:

Under the ATEX Directive 2014/34/EU , equipment for areas with an explosion hazard are assigned to groups, categories and temperature classes. Our products are assigned as follows: Ex II 2 GD c IIC T4 IIIC T135°C

**Ex II 2 GD c IIC T4 IIIC T135°C**

II	2	GD	c	IIC	T4	IIIC	T135°C	
							T135°C	Dust Temperature Class: Maximum external surface temperature 135°C
							IIIC	Groups of Dust: Protected for group IIIC which includes groups IIIA & IIIB
							T4	Gas Temperature Class: Maximum external surface temperature 135°C
							IIC	Gas Explosion Group: Protected for group IIC which includes groups IIA & IIB
							c	Protection type: Design safety
							GD	Ex Atmosphere: Gas and Dust
							2	Category: High Safety
							II	Equipment Group: surface industries





If you need a wider beam range or have specific head room requirements please contact us for bespoke solutions.

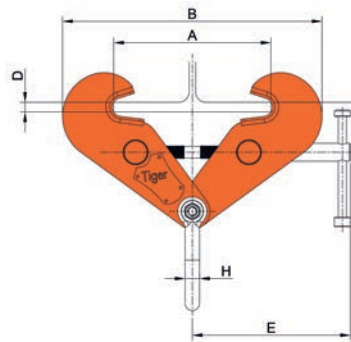
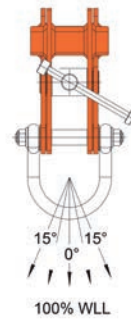
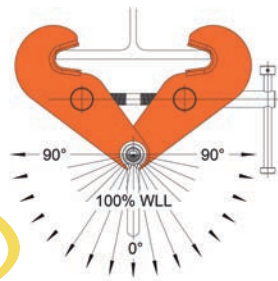

1t - 6t

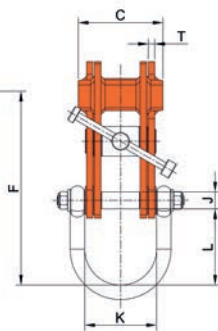

10t

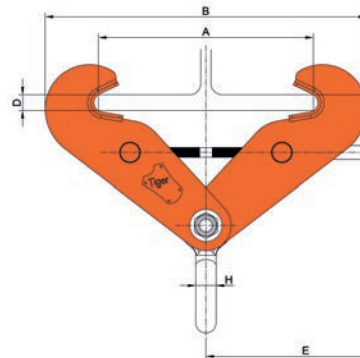

15t/20t

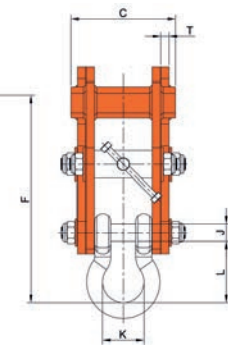

30t

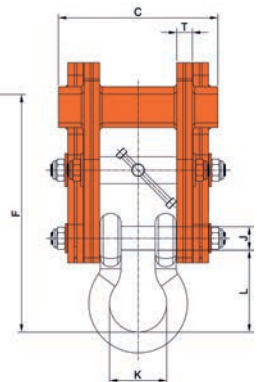
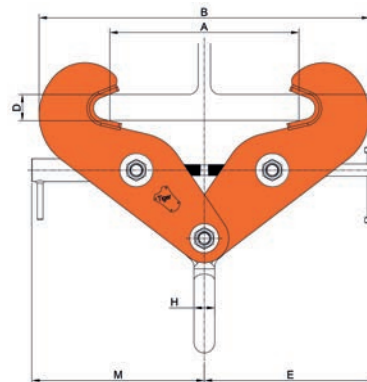

CLAMPING

Product Code	Capacity (tonne)	Dimensions (mm)												Net Weight (kg)
		A	B	C	D	E	F	H	J	K	L	M	T	
BCF-0100	1.0	75-195	206-330	105	20	195	257-230	16	21	80	84		6	5.5
BCF-0200	2.0	75-195	206-330	105	20	195	268-242	18	21	88	95		8	6.5
BCF-0300	3.0	100-350	223-488	140	25	270	364-297	22	27	110	105		10	12.0
BCF-030S	3.0	75-190	216-333	140	20	195	267-237	22	27	110	105		10	9.5
BCF-0500	5.0	100-310	223-450	140	25	288	370-320	27	27	124	111		12	14.5
BCF-050S	5.0	75-190	216-333	140	20	195	272-243	27	27	124	111		12	11.0
BCF-0600	6.0	203-457	411-691	140	42	370	486-418	27	27	124	111		12	29.9
BCF-1000	10.0	120-350	282-527	210	30	316	400-338	32	37	83	120		16	26.5
BCF-100W	10.0	203-457	415-694	210	42	370	500-430	32	37	83	120		16	44.2
BCF-1500	15.0	203-457	463-731	250	36	416	556-496	38	43.5	99	146	400	20	76
BCF-2000	20.0	203-457	471-768	300	50	416	603-540	45	49	126	179	408	24	100.0
BCF-3000	30.0	203-457	500-800	385	63	416	635-572	50	57	138	197	416	38	152.0

# Adjustable beam clamp with shackle BCS



- Range from 1.0t to 10.0t
- Quick and versatile rigging point for hoisting equipment
- Shackle suspension point
- Highly flexible – for lifting, pulling or as an anchor point
- Multi directional adjusting screw spindle for easy attachment and safe and secure grip
- Wide Beam flange adjustment range
- Operating temperature -40°C to +80°C (temperature range of -60°C to +80°C available as an option)
- Factor of safety: 5:1 for straight pulling and lifting, 4:1 at angles up to 45° (applying the appropriate reduction in WLL)
- These units meet and exceed all the requirements within BS EN 13155:2003+A2:2009 and AS4991
- Optional locking device



Optional locking device

Angle from Vertical	0°	0°-15°	15°-30°	30°-45°
Reduction Factor	Nil	17%	34%	50%
Product Code	WLL (kg)			
BCS-0100	1,000	830	660	500
BCS-0200	2,000	1,660	1,320	1,000
BCS-0300	3,000	2,500	2,000	1,500
BCS-0500	5,000	4,100	3,300	2,500
BCS-1000	10,000	8,300	6,600	5,000

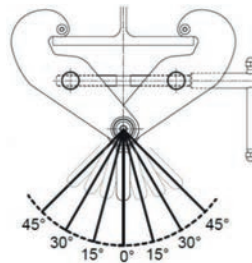

The above working load limits and derations have been established for Tiger BCS model clamps and apply only for the overhead beam attachments. They DO NOT apply when used for lifting beams.

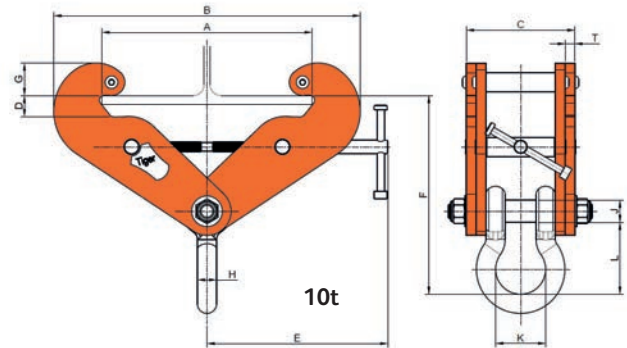
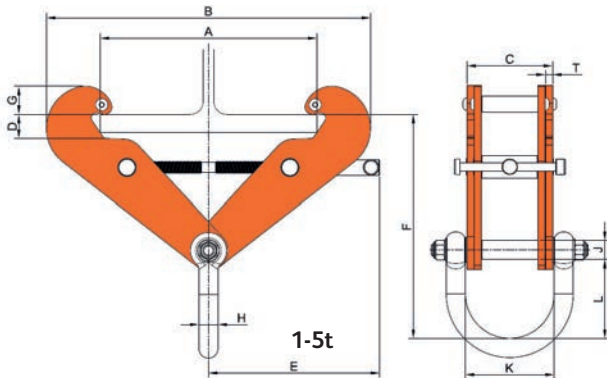

Product Code	Capacity (tonne)	Dimensions											Net Weight (kg)	
		A	B	C	D	E	F	G	H	J	K	L		T
BCS-0100	1.0	75-210	182-328	77	24	195	250-225	52-38	16	21	81	83	5	4.5
BCS-0200	2.0	75-210	182-328	85	24	195	260-236	52-38	18	21	89	94	6	5.5
BCS-0300	3.0	75-305	214-460	107	25	250	357-311	58-40	22	27	112	105	8	9.5
BCS-0500	5.0	75-305	214-460	121	25	250	363-315	58-40	27	27	125	111	10	11.0
BCS-1000	10.0	120-350	295-510	180	30	300	381-330	71-54	32	37	83	120	16	26.5

# Adjustable beam clamp BC



- Range from 1.0t to 10.0t
- Quick and versatile rigging point for hoisting equipment
- Low headroom because of the built in anchor point
- Multi directional adjusting screw spindle for easy attachment and safe and secure grip
- Wide Beam flange adjustment range
- Operating temperature -40°C to +80°C (temperature range of -60°C to +80°C available as an option)
- Factor of safety: 5:1 - for straight pulling and lifting
- These units meet and exceed all the requirements within BS EN 13155:2003+A2:2009 and AS4991
- Optional locking device

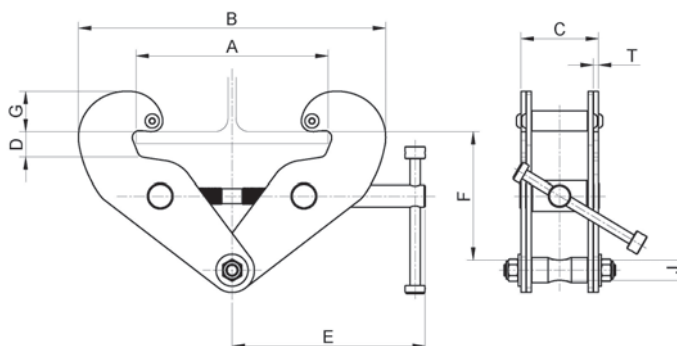

Product Code	Capacity (tonne)	Dimensions									Net Weight (kg)
		A	B	C	D	E	F	G	J	T	
BC-0100	1.0	75-210	182-328	77	24	195	144-117	52-38	20	5	4.0
BC-0200	2.0	75-210	182-328	85	24	195	144-117	52-38	20	6	4.5
BC-0300	3.0	75-305	214-460	107	25	250	224-179	58-40	22	8	8.0
BC-0500	5.0	75-305	214-460	121	25	250	224-175	58-40	28	10	10.0
BC-1000	10.0	120-350	295-510	182	30	300	222-171	71-54	43	16	24.5

CLAMPING

# Drum lifting clamp DLC



The DLC drum lifting clamp has been designed to lift drum cans. If you are lifting empty or sealed drums, then one clamp is sufficient on its own. If you are lifting an open full drum, then two clamps should be used with a two-legged sling.

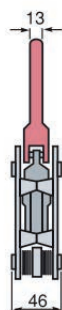
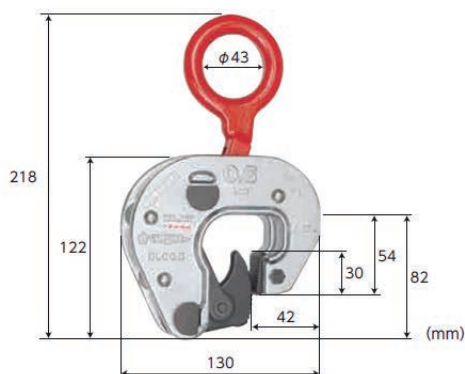

Product Code	Capacity (tonne)	Net Weight (kg)
DLC-0050	0.5	2.0



# Safety screw cam clamp CSS



The Tiger CSS safety screw cam clamp with Double Eye Anchor Points & Safety Torque Feature is suitable for many applications. This screw cam clamp is for all-purpose uses, such as lifting, lateral pulling and turning over materials. Adequacy of tightening can be visually confirmed by the visual torque safety feature.



- Spherical universal designed screw cam provides an extra powerful clamping force on a workpiece even when vibrations occur during operation
- Cam holder and collar have phosphorescent (glow-in-the-dark) paint for easy recognition of adequate torque tightening

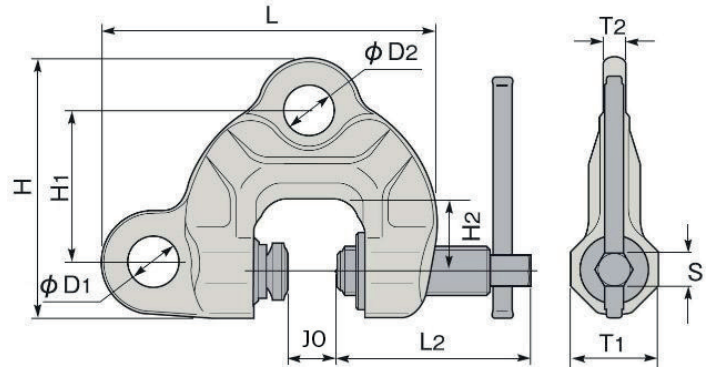

Product Code	Capacity (tonne)	Jaw Opening (mm)	Dimensions (mm)										Net Weight (kg)
			L	L2	H	H1	H2	D1	D2	T1	T2	S	
CSS-0050	0.5	0-25	158	89	121	72	30	27	27	46	13	17	1.9
CSS-0100	1.0	0-40	208	121	161	94	45	32	32	54	14	21	3.6
CSS-0200	2.0	0-40	227	121	177	105	45	36	32	60	18	21	4.8
CSS-0320	3.2	0-40	252	136	196	119	50	45	35	64	20	21	7.0
CSS-0630	6.3	0-50	291	151	225	132	55	50	41	90	43	21	17.0

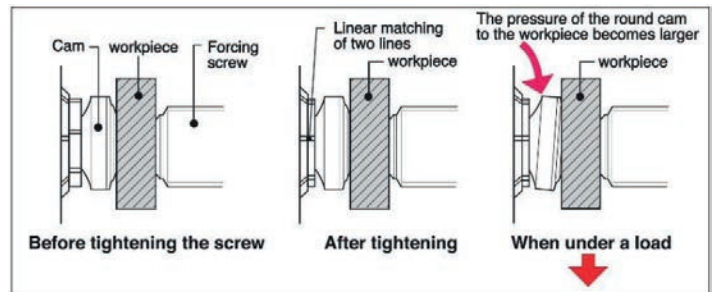
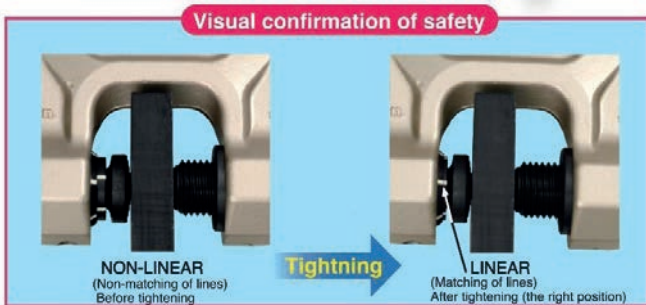

Examples of use:

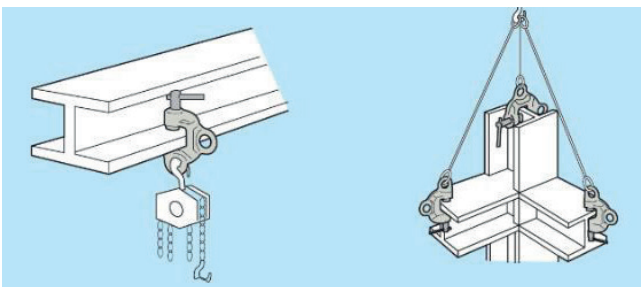

Always lift work pieces at two or more points for safety



## Screw cam clamp SCC



The SCC screw cam clamp is suitable for many applications. The omni-directional clamp can lift, hang, turn over and pull steel structures and the screw cam provides an extra powerful clamping force on the work piece.

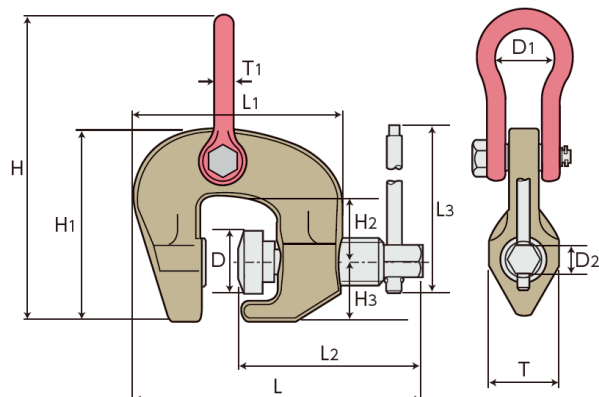

Product Code	Capacity (tonne)	Clamp range (mm)	Dimensions (mm)													Net Weight (kg)
			L (min)	L1	L2	L3	H	H1	H2	H3	D	D1	D2	T	T1	
SCC-0030W	0.3	50-100	196	176	116	75	155	91	35	16	26	17	14	32	10	1.3
SCC-0050	0.5	0-28	123	104	89	60	113	76	26.5	16	26	17	14	30	10	0.8
SCC-0100	1.0	0-30	175	148	126	190	204	128	45	38	42	38	21	46	12	3.2
SCC-0100W	1.0	50-100	258	225	153	190	273	190	88	38	42	45	21	46	16	6.0
SCC-0150	1.5	0-32	187	154	135	190	229	143	52	39	42	45	21	46	16	4.0
SCC-0300	3.0	0-50	224	190	165	240	265	165	60	45	49	50	21	54	19	6.0
SCC-0300W	3.0	25-75	250	215	165	240	291	191	76	45	49	50	21	54	19	7.8
SCC-0600	6.0	0-75	291	255	215	240	365	214	76	54	63	80	21	69	31.5	18.0

## Vertical lifting clamp SVC-E

The SVC-E Vertical Lifting Clamp is a lightweight clamp primarily designed for the vertical lifting of steel plates. The universal shackle allows the cam to generate a clamping force on the work piece no matter which direction it is pulled.

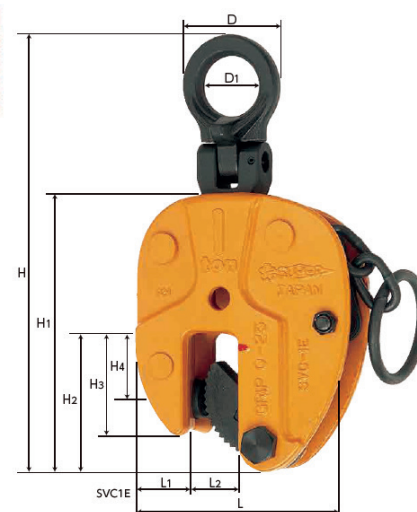
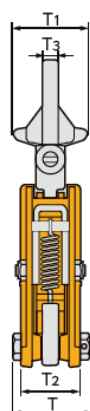

Product Code	Capacity (tonne)	Clamp range (mm)	Dimensions (mm)														Net Weight (kg)
			L	L1	L2	H (max)	H1	H2	H3	H4	D	D1	T	T1	T2	T3	
SVC-0030-E	0.3	0-16	100	25	19	176	110	57	48	30	45	26	50	39	36	8	1.6
SVC-0050-E	0.5	0-19	110	28	22	204	125	67	53	34	52	30	55.5	45	40	10	2.1
SVC-0100-E	1.0	0-25	130	35	29	257	160	80	60	38	60	35	67.5	53	48	12	3.7
SVC-0150-E	1.5	0-28	150	39	33	290	174	88	67	42	76	45	76.5	67	55	14	5.5
SVC-0200-E	2.0	0-32	162	43	37	335	194	97	73	45	94	55	82	83	58	16	7.0

## Vertical lifting clamp TVC



Tiger vertical lifting clamps are used for the safe vertical lifting and handling of pre-assembled reinforcing round or irregular shaped steel bars.

When the clamp is high out of reach the centre lever type open lock can be operated via the remote-control rope to lock the clamp into the open position.

The side stopper on the side of the body will engage when the remote-control lever is moved to upward position. The side stopper can prevent reinforcing rods coming off due to pressure from the rods.



## Screw cam clamp CSC



The Tiger CSC 'swivel hook' screw cam clamp is suitable for many applications. It is particularly useful for lifting and pulling sheet metal, girders, and steel constructions. It is fitted with a movable cam on the thread spindle which provides a powerful clamping force on the object being moved.

It can be used for lifting and transporting a large variety of different shaped steel, ranging from steel plates and structured steel to curved and spherical shaped steel. As well as transporting plates, this clamp is well-suited to turning over steel structures and welded constructions. It is also designed to be used in conjunction with a Tiger lever hoist to align steel structures of fabrications. These clamps are ideally suited for the construction industry.

When loaded, the Cam swivels in proportion to the load applied and the teeth edges of the cam bite into the plate to increase the clamping force, even when vibrations occur during operation.



## Drum lifting clamp CDL



Tiger CDL drum lifting clamp has been designed to lift and transport steel drums and is lightweight and easy to use. If you are lifting empty or sealed drums, then one clamp is sufficient on its own. If you are lifting an open full drum, then two clamps should be used with a two-legged sling.



## Vertical drum clamp CDV



The Tiger CDV-0060 drum clamp has been designed to lift and transport drums in the vertical position. One clamp can be used to lift drums with or without their lids by gripping the rim of the drum. Its lightweight and small overall design makes it ideal for picking up drums that sit tightly on pallets. The centre of gravity of the drum is below the lifting point during transportation.



## Rail clamp CRT



The Tiger CRT rail clamps are designed to lift single rails lengthways and crossways, securely and safely. The clamps are designed to fit most types of rail section currently in use. The clamps are locked onto the rail-head via a lever operated spring mechanism. Very solid, practical design with low dead weight. For rail sizes S49, S54, S60s, UIC60.





**TVC**

Product Code	Capacity (tonne)	Applicable diameters (mm)	Reinforcing steel rods	Dimensions (mm)				Net Weight (kg)
				I	L	b	B	
TVC-1L3	1.0t	16-41	D16-D38	78	234	63	124	11.0
TVC-1L5	1.0t	35-55	D35-D51	109	265	87	148	12.0

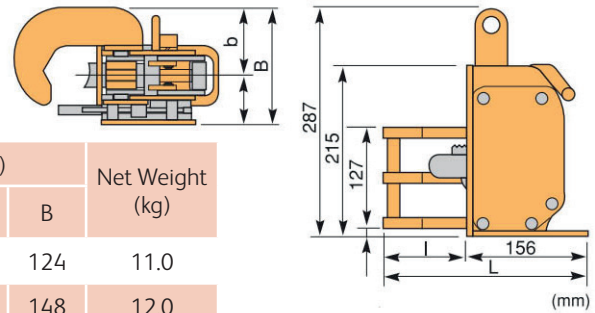

**CSC**

Product Code	Capacity (tonne)	Jaw Opening	Dimensions (mm)					Net Weight (kg)
			A	B	C	D	E	
CSC-0050	0.5	0-28	52	158	11	18	105	0.7
CSC-0150	1.5	0-32	77	210	16	30	152	4.0
CSC-0300	3.0	0-50	88	270	19	36	191	6.0
CSC-0600	6.0	0-75	153	290	32	45	255	18.0

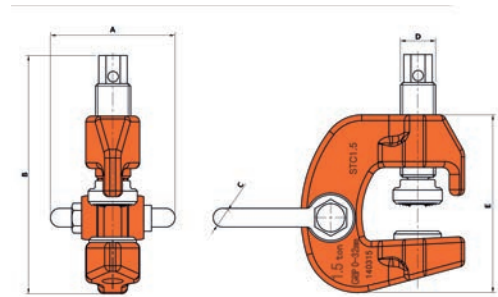

**CDL**

Product Code	Capacity (tonne)	Jaw Opening M	Dimensions (mm)				Net Weight (kg)
			A	B	C	D	
CDL-0050	0.5	0-17	128	96	40	16	1.6

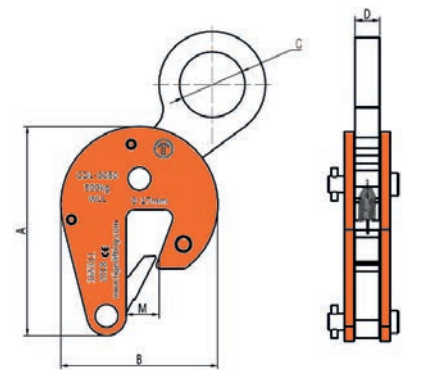

**CDV**

Product Code	Capacity (tonne)	Dimensions (mm)						Net Weight (kg)
		U	S	V	T	X	Y	
CDV-0060	0.6	765	434	305	50	100	12	7.0

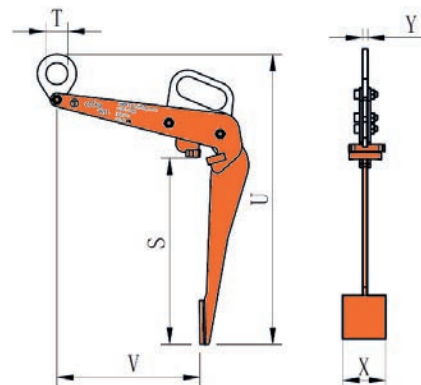

**CRT**

Product Code	Capacity (tonne)	Jaw Opening A	Dimensions (mm)				Net Weight (kg)
			B Max	C Max	D	E	
CRT-0200	2.0	15-85	170	302	60	111	6.2

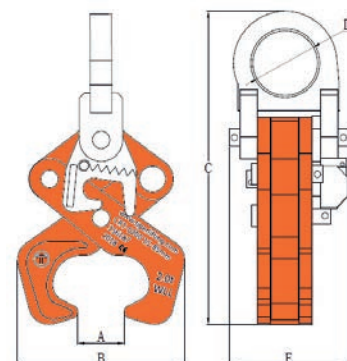

# Adjustable angle beam clamp BCA



This BCA clamp serves as an anchor or lifting point when attached to an overhead steel angle section approved for lifting applications. This clamp can be used up to a maximum of 15° from the vertical.

- 1.0t and 3.0t capacities available
- V shaped clamping jaws ensures safe and secure grip
- Designed to accommodate a wide range of steel angle sections
- No tools required – integrated adjusting screw spindle
- Operating temperature -40°C to +80°C (temperature range of -60°C to +80°C available as an option)
- Shackle suspension point
- Factor of safety: 5:1 for straight pulling and lifting, 4:1 at other angles stated
- These units meet and exceed all the requirements within BS EN 13155:2003+A2:2009 and AS4991

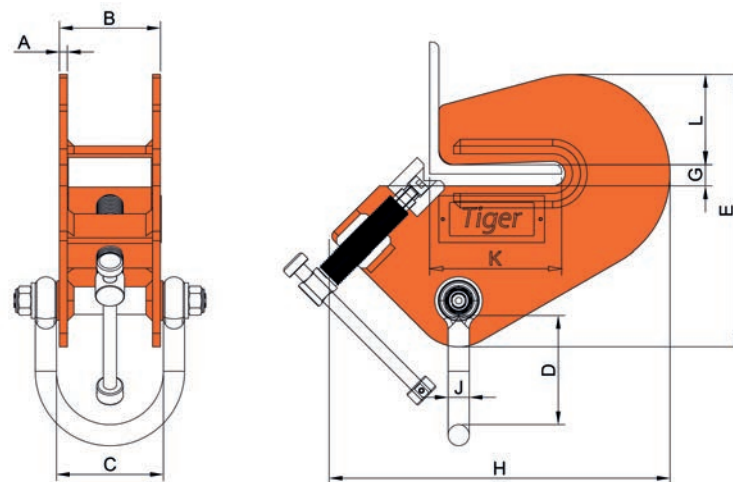

Product Code	Capacity (tonne)	Dimensions									Net Weight (kg)
		A	B	C	D	E	G	H	J	K	
BCA-0100	1.0	6	76.5	81	83	206	15	258	16	38-101	5.5
BCA-0300	3.0	10	106.5	112	104	343	25	490	22	101-203	23.5

# Industrial winch

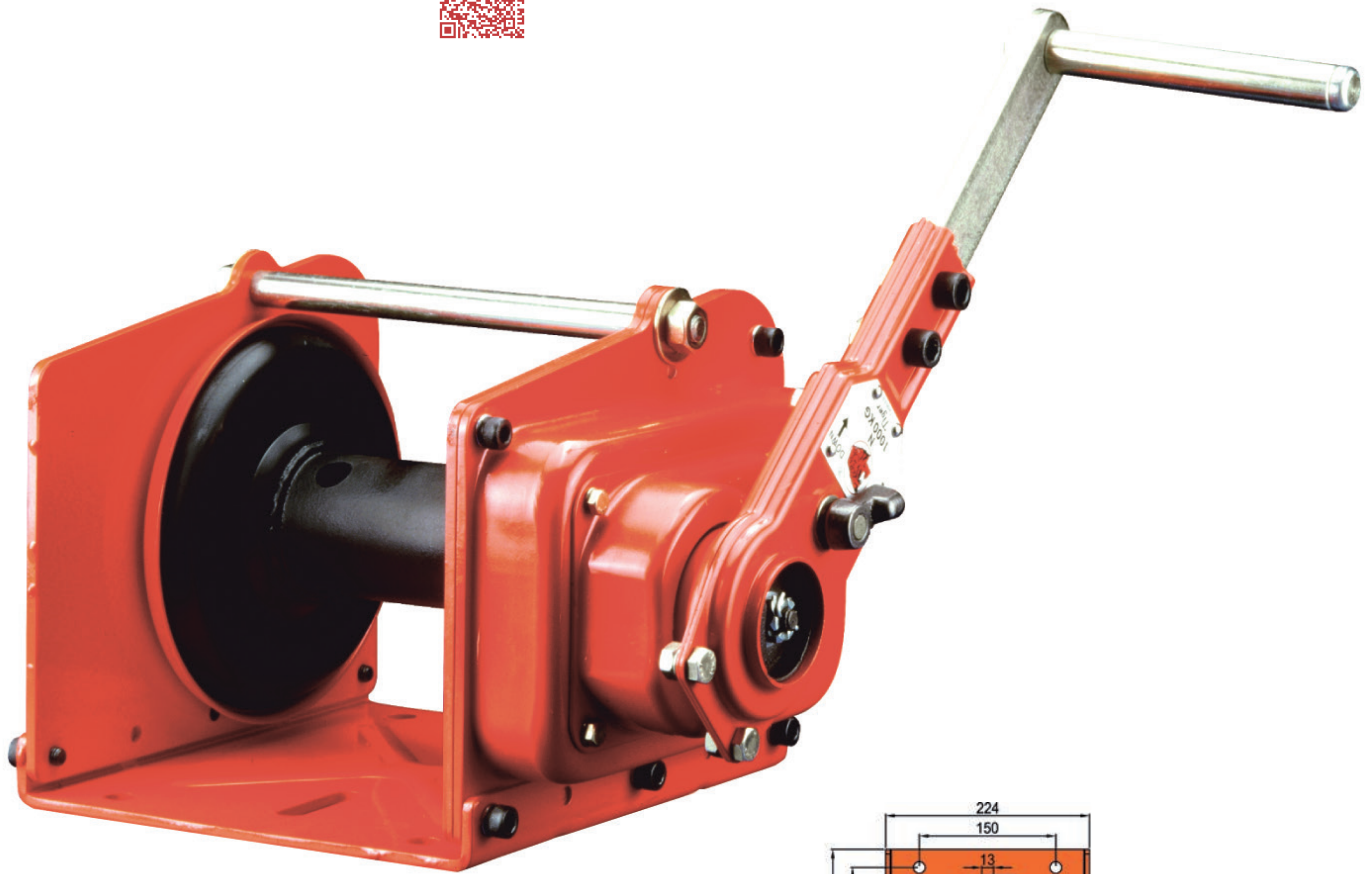

- 2200lb/1000kg lifting & 4400lb/2000kg pulling capacity
- Ratchet handle permits reciprocating handle movement in both directions for lifting and lowering loads
- Positive load-actuated brake can hold the load in any position
- Gears and brake are fully covered to prevent dust, dirt and rain contamination
- Very low operator effort is required for easy operation
- Ratchet handle accommodates installation in cramped locations such as wall and floor

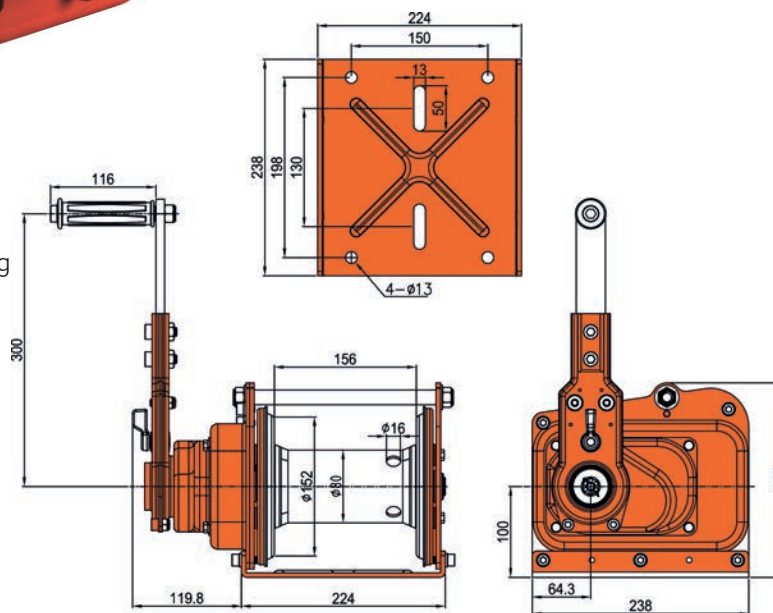

Product Code	Rated capacity (lbs/kg)	Hand force required (kg)			Gear ratio	Hub diameter	Handle length	Unit weight (with handle) (kg)	Cable diameter (mm/inch)	Cable storage cap. (m)
		1st Layer	Mid Layer	Last Layer						
SF-2200	2200/1000	11	13.5	16.5	22.2:1	Ø80	300	17.5	Ø8.0/Ø5/16	32

## Wire rope

Product Code	Description	Diameter (mm)	Breaking Load (kg)	Available for
WWR-08-32	32 meters with safety hook	8	4500	SF-2200



# Brake hand winch BHW



The Tiger Brake Winch is a high quality multi-purpose winch used for a wide variety of lifting and hoisting applications. The automatic brake ensures the load remains suspended when the crank is released and avoids unchecked descent of the load; there is no freewheeling making the hand winch extremely safe to operate. All the mechanical components are enclosed for protection against dust, dirt and rain contamination. This equipment has a lifting capacity ranging from 800lbs to 2600lbs. The BHW is compact and lightweight yet rugged and durable. These units meet and exceed all the requirements within BS EN 13157:2004+A1:2009.

- The original brake hand winch
- High quality multi-purpose winch
- Automatic load-actuated brake can hold the load in any position
- Compact, light-weight and rugged construction
- Gears and brakes fully covered to prevent dust, dirt and rain contamination
- Heat treated gears
- Very low operator effort required for easy operation
- Dual handle pinion shaft option available on all models, allows handle to be fitted on both sides
- Universal mounting plate
- Available as 800lb, 1200lb, 1800lb and 2600lb models.
- For cable and strap
- Finished in high quality powder coat paint offering excellent corrosion protection
- Noiseless 1200lb model available
- Fully corrosion protected versions available
- 3D Drawings available on full range for project planning
- Operating temperature of -40°C to +80°C (temperature range of -60°C to +80°C available as an option)



Dual Handle Option

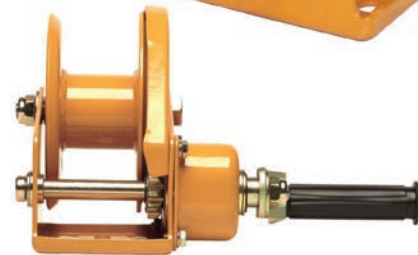

Noiseless 1200lb model (BHW-1200-N)

Product Code	Rated Capacity (lbs/kg)			Hand Force Required (kg)	Drum Cable Capacity (ft/m)			Gear ratio	Hub dia Ø (mm)	Handle length (mm)	Unit weight (kg)	Cable diameter (mm/ inch)	Cable storage cap. (m)	Strap storage cap. (m)
	1st Layer	Mid Layer	Last Layer		1st Layer	Mid Layer	Last Layer							
BHW-0800	800/370	590/270	370/170	17	6/1.8	70/21	130/40	4.1:1	Ø40	160	3.0	Ø4/ Ø5/32	40	9.1
BHW-1200	1200/550	880/400	575/260	25	5.7/1.7	43/13	82/25	4.1:1	Ø50	210	3.5	Ø5/ Ø3/16	25	8.5
BHW-1200-N	1200/550	880/400	575/260	25	5.7/1.7	43/13	82/25	4.1:1	Ø50	210	4.0	Ø5/ Ø3/16	25	8.5
BHW-1800	1800/820	1380/630	990/450	25	8/2.5	53/16	100/30	5:1	Ø70	320	8.0	Ø6/Ø1/4	30	14.1
BHW-2600	2600/1200	2000/930	1470/670	25	7.5/2.3	36/11	66/20	10:1	Ø82	320	10.5	Ø8/ Ø5/16	20	10.6

## Corrosion resistant version

This model has a fully corrosion protected body and components to ensure reliable long-term use. The external coating is completed with a two-stage finish combining electroplating as a base layer and then finished with a very hard-wearing sand texture powder coating paint which offers excellent corrosion protection and high impact protection. This coating has been proven to be effective through at least 1500 hours of the ASTM B 117 Salt Spray Test and gives the properties of stainless steel without the cost implications.



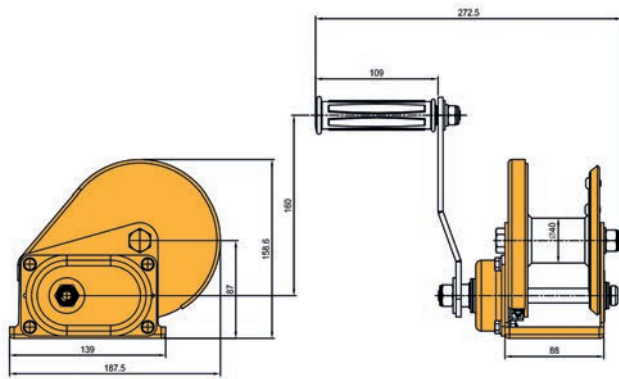

BHW-0800

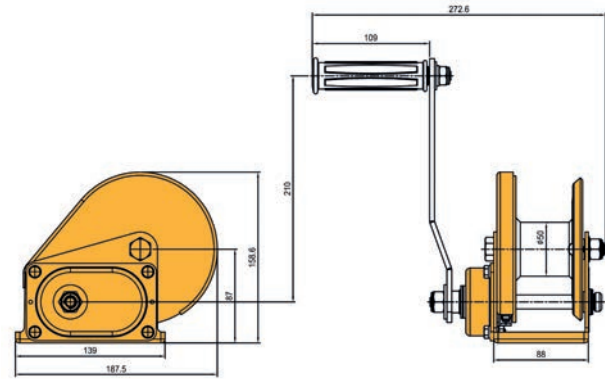

BHW-1200

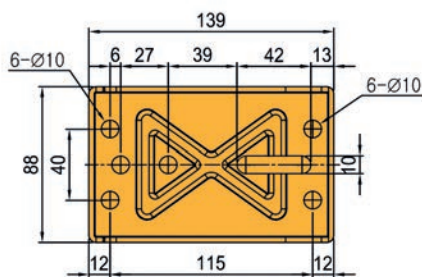

Mounting plate for BHW-0800/1200/1200-N

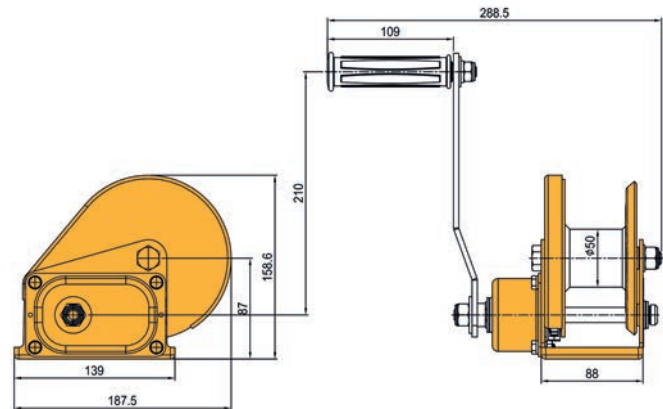

BHW-1200-N

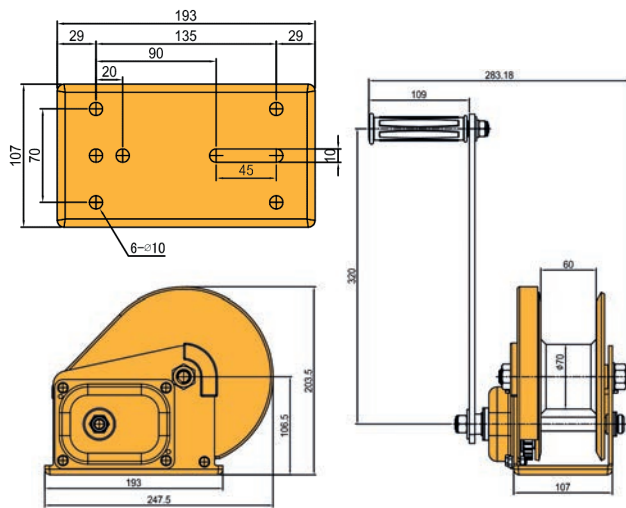

BHW-1800

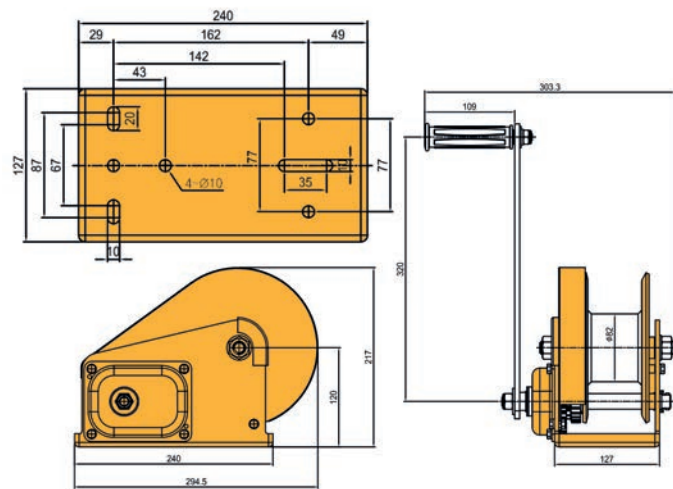

BHW-2600

**Winch straps (for pulling only)**

Product Code	Description	Width (mm)	Thickness (mm)	Breaking Load (kg)	Available for
TG-48	6 meters with safety hook	48	1.2	2068.5	BHW-0800 & BHW-1200
TG-54	9 meters with safety hook	54	1.4	2864.0	BHW-1800
TG-60	9 meters with safety hook	60	1.7	4136.0	BHW-2600

**Wire rope**

Product Code	Description	Diameter (mm)	Breaking Load (kg)	Available for
WWR-04-30	30 meters with safety hook	4	1270	BHW-0800
WWR-05-20	20 meters with safety hook	5	2000	BHW-1200
WWR-06-22	22 meters safety hook	6	3000	BHW-1800
WWR-08-16	16 meters with safety hook	8	4500	BHW-2600

# Ceiling mounted winches



## Ceiling Mounted Winch SF-5000 (wire)/SF-5000-S (strap)

- 5000lb/2270kg capacity
- Split reel, which allows for operation of two cables
- Loop drive allows the winch to be mounted out of reach and operated with an extension pole fitted to engage the loop
- Various loop sizes available
- Positive load-actuated brake can hold the load in any position
- Gears and brake are fully covered to prevent dust, dirt and rain contamination
- Very low operator effort is required for easy operation



SF-5000



SF-5000-S

## Electric Ceiling Mounted Winch SF-5000E (wire)/SF-5000E-S (strap)

- 5000lb/2270kg capacity
- Compact and light weight
- Split reel, which allows for operation of two cables
- Completely sealed to prevent dust, dirt and rain contamination
- Brake motor for quick and safe stopping
- Very low operator effort is required for easy operation
- Powerful and smooth
- Can be operated manually during power failure (option)
- Widely used in the poultry industry
- Multiple winches can be linked to control boxes as an option



SF-5000E

## Heavy Duty Worm Gear Winch WL-4600

- 4600lb/2090kg capacity
- Self-braking
- Available in regular or split reel, which allows for operation of two line or cables for greater versatility
- Completely sealed to prevent dust, dirt and rain contamination



WL-4600



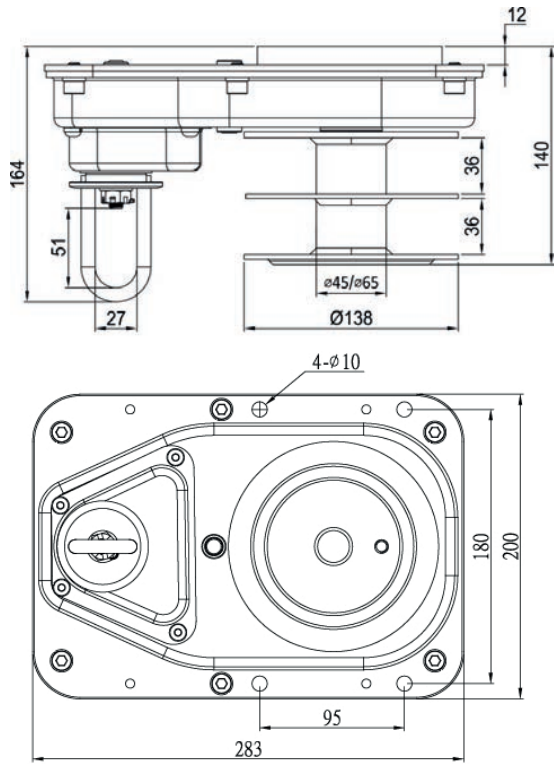

SF-5000

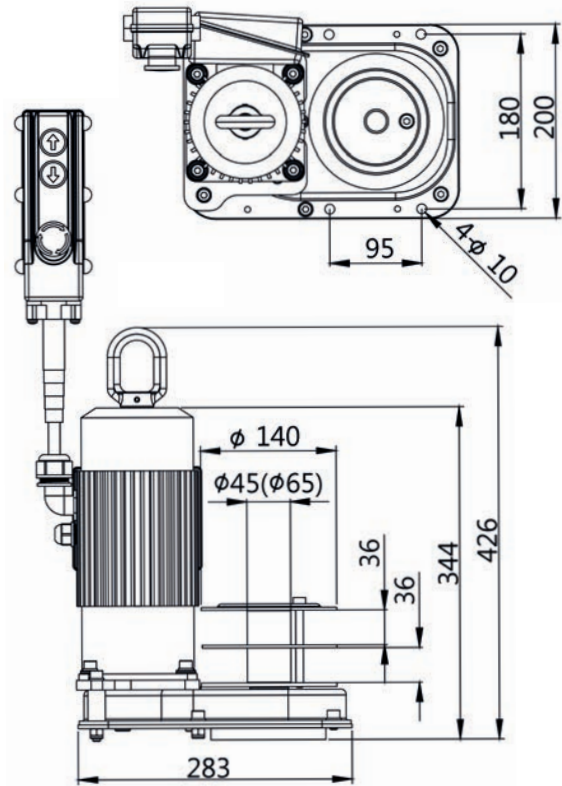

SF-5000E

Drum diameter:  
SF-5000 (for wire)=Ø65mm  
SF-5000 (for strap)=Ø45mm

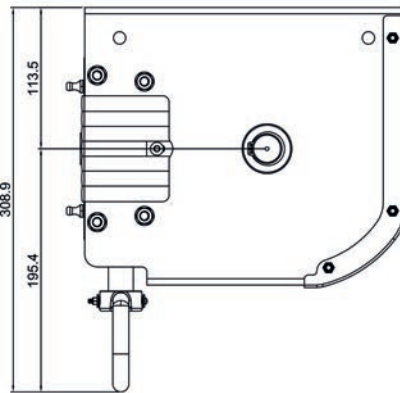
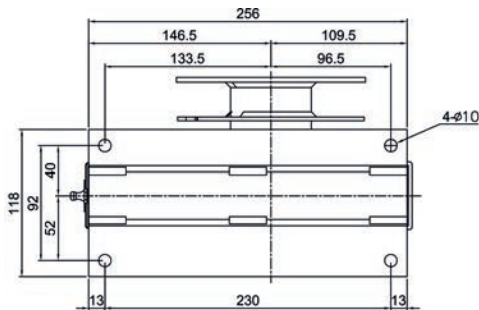

WL-4600

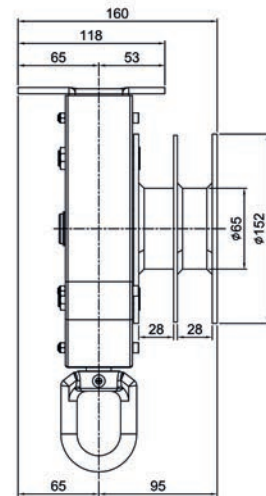

Product Code	Rated capacity (lbs/kg)	Hand force (kg)	Gear ratio	Hub diameter (mm)	Handle length (mm)	Unit weight (with handle) (kg)	Unit weight (with loop) (kg)	Cable diameter (mm/inch)	Cable storage cap. (m)
SF-5000	5000/2270	4	90.24:1	Ø65	-	-	9.3	Ø6.4/Ø1/4	11*2
SF-5000-S	5000/2270	4	90.24:1	Ø45	-	-	9.3	-	4.5*2
SF-5000E	5000/2270	-	90.24:1	Ø65	-	-	23.14	Ø6.4/Ø1/4	11*2
SF-5000E-S	5000/2270	-	90.24:1	Ø45	-	-	23.14	-	4.5*2
WL-4600	4600/2090	6	65:1	Ø65	-	-	12.5	Ø6.4/Ø1/4	11*2

When pulling in both directions, the total weight can reach the above weight. However, when pulling in only one direction, the weight needs to be halved.

# Hand winches



## General Purpose Hand Winch HW-2000

- 2000lb/900kg capacity
- Available in regular or split reel, which allows for operation of two line or cables for greater versatility
- Available in handle or loop drive models
- Can be ceiling mounted with loop drive

## General Purpose Hand Winch HW-1200

- 1200lb/545kg capacity
- Ability to disengage the gear to allow fast pay out of the cable

## General Purpose Hand Winch HW-0600

- 600lb/270kg capacity
- Ability to disengage the gear to allow fast pay out of the cable

Operating temperature -40°C to +80°C (temperature range of -60°C to +80°C available as an option)

Product Code	Split Reel	Rated Capacity (lbs/kg)	Hand Force Required (kg)	Gear Ratio	Hub Diameter (mm)	Handle Length (mm)	Unit Weight (with handle) (kg)	Unit Weight (with loop) (kg)	Cable Diameter (mm/inch)	Cable Storage Cap. (m)
HW-0600**		600/270	7	3.1:1	Ø19	175	2.2	N/A	Ø4.0/ Ø5/32	28
HW-1200		1200/545	20	4.1:1	Ø50	210	2.8	N/A	Ø4.8/ Ø3/16	29
HW-2000-S	Yes	2000/900	4.5	41:1	Ø48	190	5.7	5.4	Ø4.8/ Ø3/16	8.8 per side
HW-2000		2000/450	2.25	41:1	Ø48	190	5.5	5.2	Ø4.8/ Ø3/16	17.6

For winches with split reels, each side has half the capacity

\*\*HW-0600/1200 are for pulling purpose only.

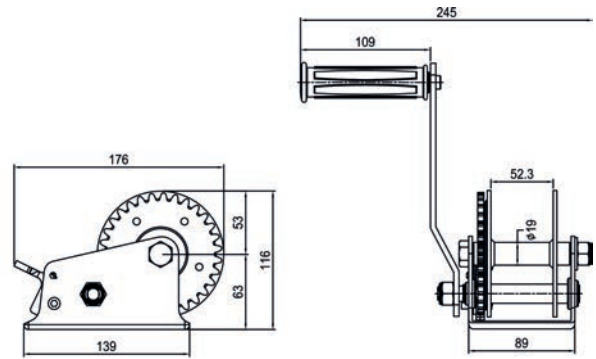
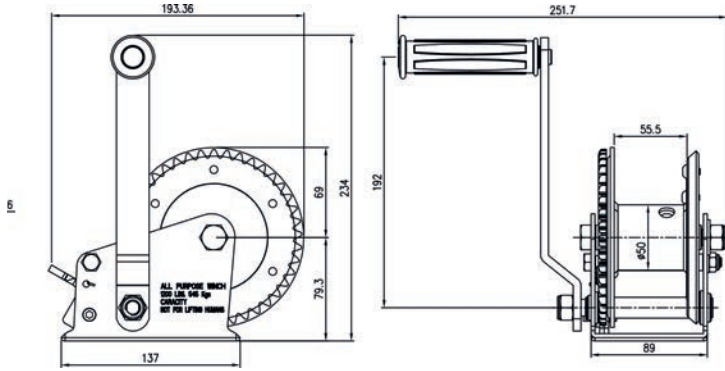
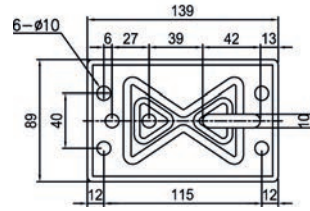
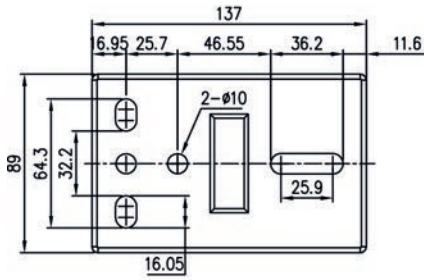

HW-1200

HW-600

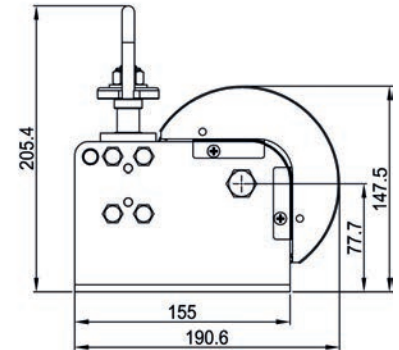
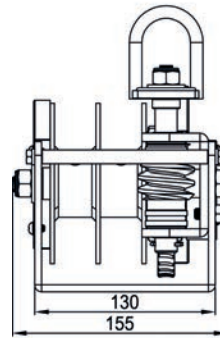
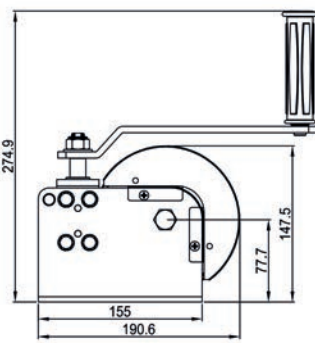
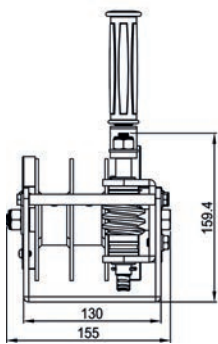

HW-2000  
(with handle)

HW-2000  
(with loop)

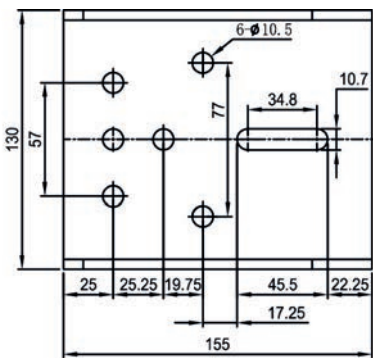



## Product guidance

The guidance that comes with our products is amongst the best in the industry and covers Safety Information, Product Operation, Inspection and Maintenance, Transport, Storage, Decommissioning and Disposal, Manufacturer Testing and Verification, Product Warranty and Warnings, Technical Data, Exploded Diagrams and an Inspection Log. Relevant chain block and lever hoist manuals also include information on using our products for cross hauling, fleeting and drifting applications.



## Quality statement

Tiger Lifting is committed to providing defect free products to its customers on time and within budget and to a standard of service that fully meets our customers' needs.

We operate a Quality Management System that has gained BS EN ISO 9001:2015 certification, including aspects specific to the design, development, manufacture and distribution of material handling equipment and associated products.

We communicate throughout our organisation the importance of meeting customer needs and all relevant statutory and regulatory requirements. We make the resources available to ensure that these needs are met and that all our staff are trained and aware of our philosophy of constant, logical, and sustainable improvement throughout every single aspect of our organisation.

## Product support

We hold complete technical files for our products to provide full back-up and reassurance on our products' performance and to ensure that advice for our equipment is readily available. We have a wealth of technical expertise and qualified personnel as well as specialised dealers and distributors to provide competent know-how, service and full product support.

## Product documentation

Our products are provided with all relevant documentation, for example an EC Declaration of Conformity confirming the tested status of the product.

We can also supply Type 3.1 Inspection Certificates In Accordance With BS EN 10204:2004 (E) (Material certificates) if required.

Certificates of Origin attested by our Chamber of Commerce can be supplied for export orders, along with other relevant export documentation.

## Returns policy

We would like to draw your attention to Tiger Lifting's policy on the returning of goods, either when:

- a. Incorrect goods have been ordered by the distributor or end user.
- b. Goods have been despatched but are later cancelled or unwanted by the distributor or end user.

On either of the above occasions, unless otherwise confirmed in writing to the contrary, we will levy a standard handling charge. This charge covers handling costs as well as QA and inspection of returned goods. The handling charge ranges from 15% to 25% of the net value less any carriage charges, depending on the goods and their condition. Items manufactured to customers' special requirements cannot be returned for credit.

Before returning any goods you must contact us for authorisation. The item is your responsibility until it reaches us. Therefore for your own protection we recommend that you send the goods using a delivery service that insures you for the value of the goods. The cost of returning the item to us is your responsibility.

When we receive the goods, we will inspect each item before it is accepted back. Goods that can't be returned to a saleable condition will not be accepted back. The acceptance or not of the goods and the handling charge to be applied will then be communicated back to you.

## Copyright

The Tiger logo and brand are registered trademarks and subject to copyright.

We are happy to release the copyright of our images for use on distributors' websites or in their own publications provided that written consent is obtained from Tiger Lifting. Please contact our marketing department for photographs, logos and other marketing information.

## Terms and conditions

To view our terms and conditions please visit: [www.tigerlifting.com/terms-conditions/](http://www.tigerlifting.com/terms-conditions/)

## Disclaimer

We believe that the information in this document, including technical information and any advice, is reliable although we give no guarantee as to its accuracy or completeness. The user of our products must determine if the product, either used alone or in conjunction with other products, is suitable for their purpose and assumes all risk and liability in connection with those decisions. You are strongly advised to carry out a risk assessment before selecting Tiger products for any proposed application.

Before using any product we offer, you must read and understand the product user guide for that product. The use of every product we offered is governed by separate and unique instructions and safety warnings. The information provided in this catalogue does not supplement or supersede those warnings. To the extent product information presented in this catalogue is inconsistent with the product information or safety information for a specific product, the information and warnings that accompany the specific product shall govern its use.

Tiger Lifting will not be held liable for any malfunction, lack of performance or accident if the product is being used in conjunction with any unauthorised part or not in accordance with the operating instructions.

We have made every effort to make sure this document is accurate. The information contained in this document does not form part of any contract. Mistakes and errors reserved.

Due to our policy of continual product development, dimensions, weights and specifications may change without prior notice. Please check with your Tiger sales team when ordering.



**Tiger**

### Tiger HQ Taiwan

6F, No. 118-1  
ZhongZheng Road  
Shilin Dist.,  
Taipei City  
11145  
Taiwan

Telephone: +886-2-2831 3035  
Fax: +886-2-2834 0188  
info@tigerlifting.com.tw

### Tiger China - Sales office

Telephone: +86 (0) 22 5984 8679  
Mobile: +86 138 2377 3024  
info@tigerlifting.com.cn

### Tiger UK and Europe

Coquet Enterprise Park  
Amble  
Morpeth  
Northumberland  
NE65 0PE  
United Kingdom

Telephone: +44 (0) 1665 605130  
info@tigerlifting.com

### Tiger South East Asia

Blk 18, Boon Lay Way, #05-126  
Tradehub 21  
609966  
Singapore

Telephone: +65 8816 6418  
info@tigerlifting.com.sg

### Tiger North America

38381  
N.Robert Wilson Road, Suite B  
Gonzales  
Louisiana  
70737  
USA

Telephone: +1 225-647-1312  
+1 833-681-3057  
Fax: +1 225-647-1322  
sales@tigerliftingna.com



V1.1 | 2025 | tigerlifting.com