

Vertical Lifting Clamp Model No. SVC-E



Main Features

- Range from 0.3t to 2.0t
- Lightweight clamp primarily designed for the vertical lifting of steel plates
- The spring-loaded tightening lock mechanism assures a positive initial clamping force even at no load condition
- The universal shackle allows the cam to generate a clamping force on the work piece no matter which direction it is pulled
- The clamping force increases in proportion to the weight of the load
- High-frequency quenching of die-forged special alloy steels gives greater durability to the cam



These units meet and exceed all the requirements within BS EN 13155:2003.

Certification:

Each unit comes fully certified with a test certificate or an EC Declaration of Conformity stating compliance with the essential health and safety requirements of the Machinery Directive 2006/42/EC.

Technical Data

Product Code	Capacity (tonne)	Clamp Range (mm)	Dimensions (mm)														Net Weight (kg)
			L	L1	L2	H (Max)	H1	H2	H3	H4	D	D1	T	T1	T2	T3	
SVC-0030-E	0.3	0-16	100	25	19	176	110	57	48	30	45	26	50	39	36	8	1.6
SVC-0050-E	0.5	0-19	110	28	22	204	125	67	53	34	52	30	55.5	45	40	10	2.1
SVC-0100-E	1.0	0-25	130	35	29	257	160	80	60	38	60	35	67.5	53	48	12	3.7
SVC-0150-E	1.5	0-28	150	39	33	290	174	88	67	42	76	45	76.5	67	55	14	5.5
SVC-0200-E	2.0	0-32	162	43	37	335	194	97	73	45	94	55	82	83	58	16	7.0

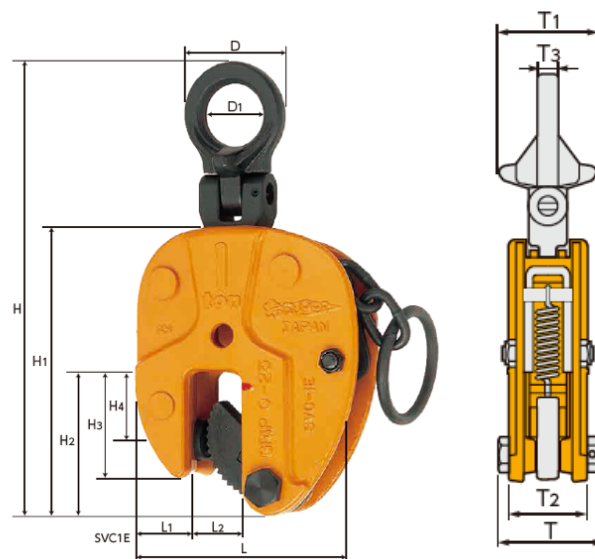

Due to our policy of continual product development, dimensions, weights and specifications may change without prior notice. Please check with your Tiger sales team when ordering.