

G80 Clevis Container Link Model No. 8-069



Main Features

- Design factor 4:1 proof tested and certified

Certification:

Each unit comes fully certified with a test certificate or an EC Declaration of Conformity stating compliance with the essential health and safety requirements of the Machinery Directive 2006/42/EC, the Supply of Machinery (Safety) Regulations 2008 and Section 6 of the Health and Safety at Work Etc Act 1974.

Manufactured and tested in accordance with EN1677-1. All YOKE Lifting points meet or exceed all the requirements of ASME B30.26.



Technical Data

Product Code	Capacity (tonne)	For Grade 80 Chain	Dimensions (mm)					Net Weight (kg)
			A	B	K	L	W	
8-069-13	5.3	13	14	125	141	57	65	1.8

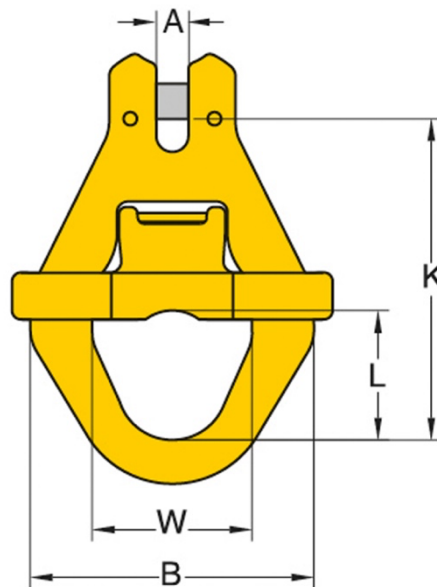

Due to our policy of continual product development, dimensions, weights and specifications may change without prior notice. Please check with your Tiger sales team when ordering.