

Excavator Hook - Metric Thread Model No. 8-083



Main Features

- Manufactured from forged alloy steel, quenched and tempered
- Tested and certified by DGUV GS-OA-15-03.
- Load rated parts are 100 % magnaflux crack detected
- Individual forged parts are traceable to Test Certification
- All YOKE Lifting points meet or exceed all the requirements of ASME B30.26
- WLL forged onto each product for quick and easy identification
- Lugs designed to assist the welding process



Certification:

Each unit comes fully certified with a test certificate or an EC Declaration of Conformity stating compliance with the essential health and safety requirements of the Machinery Directive 2006/42/EC, the Supply of Machinery (Safety) Regulations 2008 and Section 6 of the Health and Safety at Work Etc Act 1974.

Manufactured and tested in accordance with EN1677-1. All YOKE Lifting points meet or exceed all the requirements of ASME B30.26.

Technical Data Metric

| Product Code | Capacity (tonne) | Dimensions (mm) | | | | | | | | Net Weight (kg) |
|--------------|------------------|-----------------|----|-----|----|----|-----|----|----|-----------------|
| | | F | H | L | P | T | W | HV | a | |
| 8-083-0075 | 0.75 | 19 | 20 | 56 | 19 | 13 | 82 | 5 | 3 | 0.3 |
| 8-083-01 | 1.00 | 25 | 27 | 72 | 27 | 17 | 95 | 6 | 4 | 0.6 |
| 8-083-02 | 2.00 | 30 | 30 | 86 | 33 | 20 | 114 | 8 | 5 | 0.9 |
| 8-083-03 | 3.00 | 35 | 32 | 105 | 30 | 23 | 132 | 10 | 6 | 1.4 |
| 8-083-04 | 4.00 | 42 | 38 | 112 | 30 | 29 | 140 | 11 | 7 | 1.9 |
| 8-083-05 | 5.00 | 45 | 47 | 131 | 32 | 30 | 165 | 12 | 8 | 2.9 |
| 8-083-08 | 8.00 | 50 | 51 | 133 | 34 | 40 | 172 | 13 | 9 | 3.5 |
| 8-083-10 | 10.00 | 55 | 57 | 170 | 51 | 43 | 220 | 14 | 9 | 6.3 |
| 8-083-15 | 15.00 | 60 | 67 | 191 | 53 | 50 | 240 | 15 | 12 | 8.8 |

Technical Data Imperial

| Product Code | Capacity (tonne) | Dimensions (inch) | | | | | | | | Net Weight (lbs) |
|--------------|------------------|-------------------|------|------|------|------|------|------|------|------------------|
| | | F | H | L | P | T | W | HV | a | |
| 8-083-0075 | 0.75 | 0.75 | 0.79 | 2.20 | 0.75 | 0.51 | 3.21 | 0.20 | 0.12 | 0.6 |
| 8-083-01 | 1.00 | 0.98 | 1.06 | 2.83 | 1.06 | 0.67 | 3.74 | 0.24 | 0.16 | 1.2 |
| 8-083-02 | 2.00 | 1.18 | 1.18 | 3.39 | 1.30 | 0.79 | 4.49 | 0.31 | 0.20 | 2.0 |
| 8-083-03 | 3.00 | 1.38 | 1.26 | 4.13 | 1.18 | 0.91 | 5.20 | 0.39 | 0.24 | 3.1 |
| 8-083-04 | 4.00 | 1.65 | 1.50 | 4.41 | 1.18 | 1.14 | 5.51 | 0.43 | 0.28 | 4.3 |
| 8-083-05 | 5.00 | 1.77 | 1.85 | 5.16 | 1.26 | 1.18 | 6.50 | 0.47 | 0.31 | 6.3 |
| 8-083-08 | 8.00 | 1.97 | 2.01 | 5.24 | 1.34 | 1.57 | 6.77 | 0.51 | 0.35 | 7.7 |
| 8-083-10 | 10.00 | 2.17 | 2.24 | 6.69 | 2.01 | 1.69 | 8.66 | 0.55 | 0.35 | 14.0 |
| 8-083-15 | 15.00 | 2.36 | 2.64 | 7.52 | 2.09 | 1.97 | 9.45 | 0.59 | 0.47 | 19.3 |

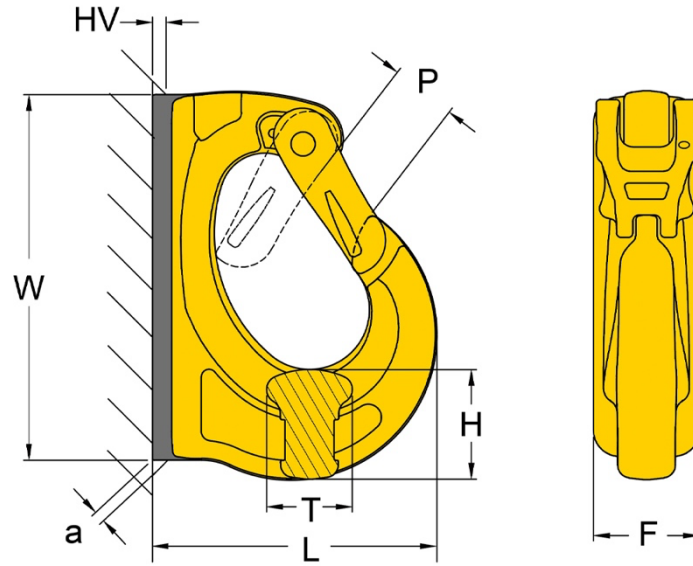

Kind of attachment

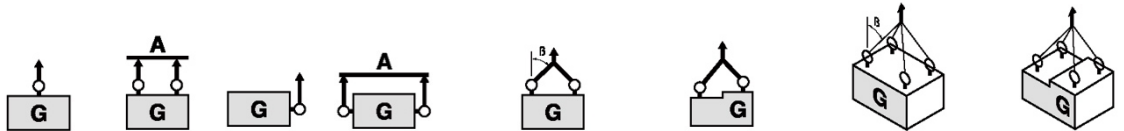

| Number of legs | 1 | 2 | 1 | 2 | 2 | 2 | 2 | 3-4 | 3-4 | 3-4 |
|----------------|---------|------|------|------|-------|---------|---------|-------|---------|---------|
| Load direction | 0° | 0° | 90° | 90° | 0-45° | 45°-60° | unsymm. | 0-45° | 45°-60° | unsymm. |
| Product Code | WLL (t) | | | | | | | | | |
| 8-083-01 | 1.0 | 2.0 | 1.0 | 2.0 | 1.4 | 1.0 | 1.0 | 2.1 | 1.5 | 1.0 |
| 8-083-02 | 2.0 | 4.0 | 2.0 | 4.0 | 2.8 | 2.0 | 2.0 | 4.2 | 3.0 | 2.0 |
| 8-083-03 | 3.0 | 6.0 | 3.0 | 6.0 | 4.2 | 3.0 | 3.0 | 6.3 | 4.5 | 3.0 |
| 8-083-04 | 4.0 | 8.0 | 4.0 | 8.0 | 5.6 | 4.0 | 4.0 | 8.4 | 6.0 | 4.0 |
| 8-083-05 | 5.0 | 10.0 | 5.0 | 10.0 | 7.0 | 5.0 | 5.0 | 10.5 | 7.5 | 5.0 |
| 8-083-08 | 8.0 | 16.0 | 8.0 | 16.0 | 11.2 | 8.0 | 8.0 | 16.8 | 12.0 | 8.0 |
| 8-083-10 | 10.0 | 20.0 | 10.0 | 20.0 | 14.0 | 10.0 | 10.0 | 21.0 | 15.0 | 10.0 |
| 8-083-15 | 15.0 | 30.0 | 15.0 | 30.0 | 21.0 | 15.0 | 15.0 | 31.5 | 22.5 | 15.0 |

Due to our policy of continual product development, dimensions, weights and specifications may change without prior notice. Please check with your Tiger sales team when ordering.