

Digital Lifting Point - Long Bolt Model No. 8-211L



Main Features

- Rotates through 360° and pivots 90°
- Manufactured from alloy steel, quenched and tempered
- Tested in accordance with EN1677-1
- Certified by DGUV GS-OA 15-04
- Load rated parts are 100 % magnaflux crack detected
- Individual forged parts and cap screw are traceable to Test Certification
- Bolts are Metric thread
- Proof tested to 2.5 times the WLL
- Fatigue rated to 20,000 cycles at 1.5 times the WLL
- All YOKE Lifting points meet or exceed all the requirements of ASME B30.26
- Quick and simple assembly, just a tapped hole is required

Certification:

Each unit comes fully certified with a test certificate or an EC Declaration of Conformity stating compliance with the essential health and safety requirements of the Machinery Directive 2006/42/EC, the Supply of Machinery (Safety) Regulations 2008 and Section 6 of the Health and Safety at Work Etc Act 1974.

Manufactured and tested in accordance with EN1677-1. All YOKE Lifting points meet or exceed all the requirements of ASME B30.26.



Technical Data

Product Code	Capacity (tonne)	Thread version		Pitch DIN1 3	Dimensions (mm)														Torque in (Nm)	Net Weight (kg)
		M (mm)	E (mm)		A	B	C	D	F	G	H	S	SW	I	J	K	L	N		
8-211-003/105L	0.30	M8	76	1.25	30	35	35	11	86	55	29	6	13	41	77	34	41	24	30	0.4
8-211-006/125L	0.63	M10	96	1.50	30	35	36	11	86	55	29	6	17	42	78	34	40	24	60	0.4
8-211-010/150L	1.00	M12	114	1.75	33	38	44	14	99	57	36	8	19	44	89	38	42	31	100	0.5
8-211-015/185L	1.50	M16	149	2.00	33	38	46	14	99	57	36	10	24	45	89	38	40	31	150	0.7
8-211-025/230L	2.50	M20	187	2.50	50	54	56	16	142	82	43	12	30	74	132	53	70	49	250	1.7
8-211-040/265L	4.00	M24	221	3.00	50	54	59	16	143	82	44	14	36	74	132	53	67	45	400	2.0
8-211-050/340L	5.00	M30	279	3.50	60	65	81	23	170	99	62	17	46	80	153	64	67	59	500	2.9
8-211-080/300L	8.00	M36	222	4.00	77	85	101	27	225	124	78	22	55	112	205	80	97	69	800	6.9
8-211-100/350L	10.00	M42	272	4.50	77	85	104	27	225	124	78	24	65	113	204	79	94	69	1000	7.9
8-211-150/350L	15.00	M42	264	4.50	95	104	112	36	258	158	86	24	65	127	229	98	110	98	1500	13.5
8-211-200/385L	20.00	M48	295	5.00	95	104	120	36	260	158	90	27	75	126	230	99	104	98	2000	15.5

Other sizes available - please ask for details.

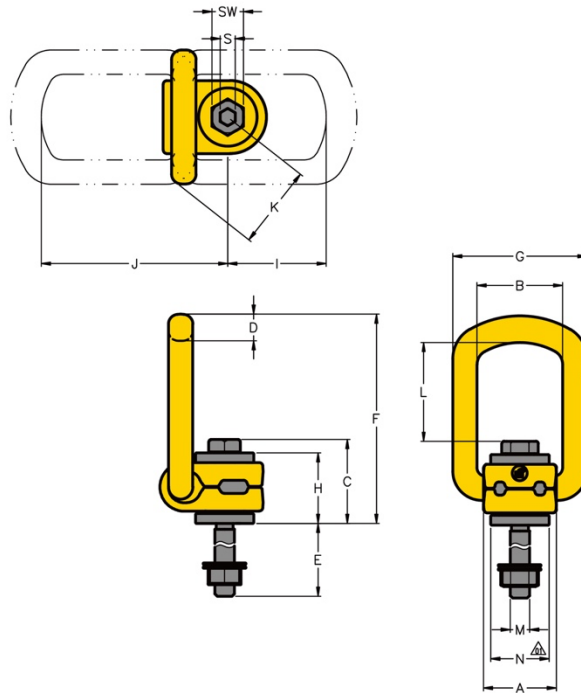

Kind of attachment

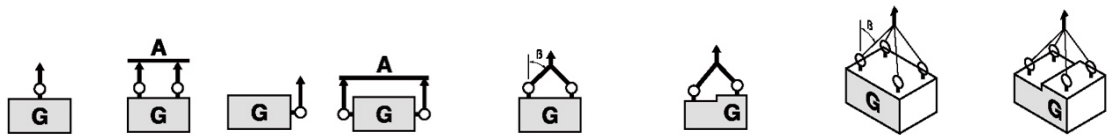

Number of legs	1	2	1	2	2	2	2	3-4	3-4	3-4	
Load direction	0°	0°	90°	90°	0-45°	45°-60°	unsymm.	0-45°	45°-60°	unsymm.	
Product Code	Thread		WLL (t)								
8-211-003/105L	M8	0.30	0.60	0.30	0.60	0.42	0.30	0.30	0.63	0.45	0.30
8-211-006/125L	M10	0.63	1.26	0.63	1.26	0.88	0.63	0.63	1.32	0.95	0.63
8-211-010/150L	M12	1.00	2.00	1.00	2.00	1.40	1.00	1.00	2.10	1.50	1.00
8-211-015/185L	M16	1.50	3.00	1.50	3.00	2.10	1.50	1.50	3.15	2.20	1.50
8-211-025/230L	M20	2.50	5.00	2.50	5.00	3.50	2.50	2.50	5.25	3.70	2.50
8-211-040/265L	M24	4.00	8.00	4.00	8.00	5.60	4.00	4.00	8.40	6.00	4.00
8-211-050/340L	M30	5.00	10.00	5.00	10.00	7.00	5.00	5.00	10.50	7.50	5.00
8-211-080/300L	M36	8.00	16.00	8.00	16.00	11.20	8.00	8.00	16.80	12.00	8.00
8-211-100/350L	M42	10.00	20.00	10.00	20.00	14.00	10.00	10.00	21.00	15.00	10.00
8-211-150/350L	M42	15.00	30.00	15.00	30.00	21.00	15.00	15.00	31.50	22.50	15.00
8-211-200/385L	M48	20.00	40.00	20.00	40.00	28.00	20.00	20.00	42.00	30.00	20.00

Due to our policy of continual product development, dimensions, weights and specifications may change without prior notice. Please check with your Tiger sales team when ordering.