

## Digital Hoist Ring - Metric Thread Model No. 8-203



### Main Features

- Rotates through 360° and pivots 180°, and simultaneously allows lifting from any direction
- Manufactured from forged alloy steel, quenched and tempered
- Manufactured and tested in accordance with EN1677-1
- Load rated parts are 100 % magnaflux crack detected
- Individual forged parts and cap screw are traceable to Test Certification
- Bolts are Metric thread
- Proof tested to 2.5 times the WLL
- Fatigue rated to 20,000 cycles at 1.5 times the WLL
- All YOKE Lifting points meet or exceed all the requirements of ASME B30.26
- Quick and simple assembly, just a tapped hole is required

### Certification:

Each unit comes fully certified with a test certificate or an EC Declaration of Conformity stating compliance with the essential health and safety requirements of the Machinery Directive 2006/42/EC, the Supply of Machinery (Safety) Regulations 2008 and Section 6 of the Health and Safety at Work Etc Act 1974.

Manufactured and tested in accordance with EN1677-1. All YOKE Lifting points meet or exceed all the requirements of ASME B30.26.



### Technical Data

Product Code	Capacity/WLL (tonnes)		Thread version		Pitch DIN13	Dimensions (mm)							Torque in (Nm)	Net Weight (kg)
	5:1	4:1	M (mm)	E (mm)		A	B	C	D	F	G	H		
8-203-004	0.40	0.50	M8	17	1.25	40	41	41	9	102	65	33	10	0.4
8-203-005	0.45	0.55	M10	11	1.50	40	41	43	9	102	65	33	16	0.5
§ 8-203-005L	0.45	0.55	M10	26	1.50	40	41	43	9	102	65	33	16	0.5
8-203-010	1.05	1.30	M12	15	1.75	65	58	57	15	158	105	45	38	1.7
§ 8-203-010L	1.05	1.30	M12	30	1.75	65	58	57	15	158	105	45	38	1.7
8-203-019	1.90	2.40	M16	20	2.00	65	58	61	15	158	105	45	81	1.8
§ 8-203-019L	1.90	2.40	M16	35	2.00	65	58	61	15	158	105	45	81	1.8
8-203-021	2.15	2.70	M20	25	2.50	65	58	65	15	158	105	45	136	1.8
§ 8-203-021L	2.15	2.70	M20	45	2.50	65	58	65	15	158	105	45	136	1.9
8-203-030	3.00	3.75	M20	25	2.50	85	73	74	22	204	134	54	136	4.0
§ 8-203-030L	3.00	3.75	M20	45	2.50	85	73	74	22	204	134	54	136	5.2
8-203-042	4.20	5.25	M24	26	3.00	85	73	78	22	204	134	54	312	4.2
§ 8-203-042L	4.20	5.25	M24	56	3.00	85	73	78	22	204	134	54	312	4.3
8-203-070	7.00	8.75	M30	81	3.50	100	80	77	25	218	160	58	637	6.6
8-203-110	11.00	13.75	M36	76	4.00	120	106	108	36	308	220	85	1005	15.0
8-203-125	12.50	15.60	M42	95	4.50	120	106	111	36	308	220	85	1005	16.0
8-203-135	13.50	16.90	M48	105	5.00	120	106	115	36	308	220	85	1350	16.0

\* Design factor 4:1

§ Long Bolts are designed for soft metal work piece.

Surface Treatment: The Dacromet original silver colour.

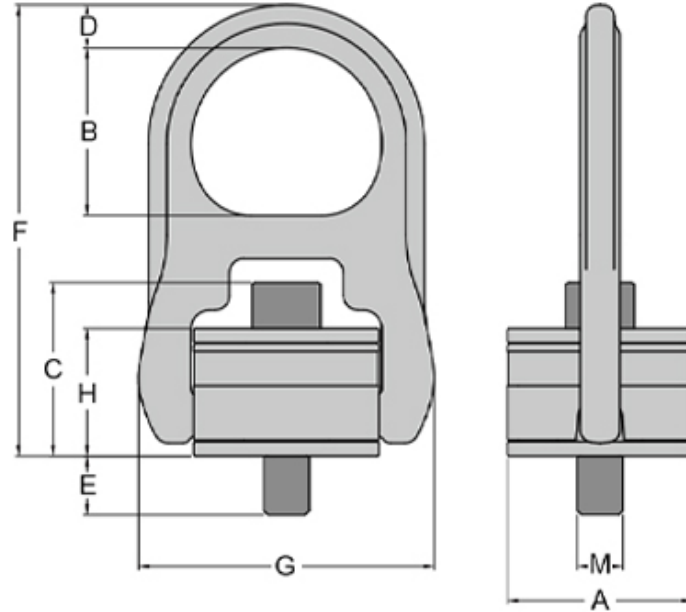

Kind of attachment

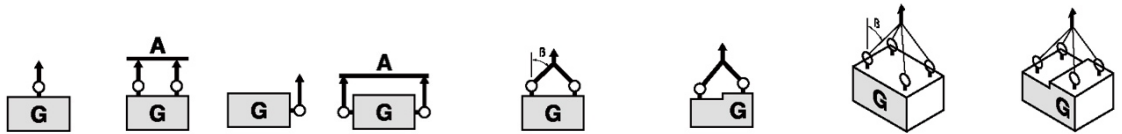

Number of legs	1	2	1	2	2	2	2	3-4	3-4	3-4	
Load direction	0°	0°	90°	90°	0-45°	45°-60°	unsymm.	0-45°	45°-60°	unsymm.	
Product Code	Thread	WLL (t)									
8-203-004	M8	0.50	1.0	0.50	1.0	0.70	0.50	0.50	1.05	0.75	0.50
8-203-005	M10	0.55	1.1	0.55	1.1	0.77	0.55	0.55	1.16	0.83	0.55
8-203-010	M12	1.30	2.6	1.30	2.6	1.82	1.30	1.30	2.73	1.95	1.30
8-203-019	M16	2.40	4.8	2.40	4.8	3.36	2.40	2.40	5.04	3.60	2.40
8-203-021	M20	2.70	5.4	2.70	5.4	3.78	2.70	2.70	5.67	4.05	2.70
8-203-030	M20	3.75	7.5	3.75	7.5	5.25	3.75	3.75	7.88	5.63	3.75
8-203-042	M24	5.25	10.5	5.25	10.5	7.35	5.25	5.25	11.03	7.88	5.25
8-203-070	M30	8.75	17.5	8.75	17.5	12.25	8.75	8.75	18.38	13.13	8.75
8-203-110	M36	13.75	27.5	13.75	27.5	19.25	13.75	13.75	28.88	20.63	13.75
8-203-125	M42	15.60	31.2	15.60	31.2	21.84	15.60	15.60	32.76	23.40	15.60
8-203-135	M48	16.90	33.8	16.90	33.5	23.66	16.90	16.90	35.49	25.35	16.90

Due to our policy of continual product development, dimensions, weights and specifications may change without prior notice. Please check with your Tiger sales team when ordering.