



G100 Clevis Foundry Hook Model No. X-046



Main Features

- Design factor 4:1 proof tested and certified
- Quenched and Tempered Alloy Steel
- At least 25 % greater WLL than traditional G80 products
- Manufactured in accordance with DIN PAS 1061 and ASTM A952/A 952M, EN 1677- 1
- Certified by DGUV GS-OA-15-05
- Fatigue rated to 20,000 cycles at 1.5 times the WLL
- Tempering temperature minimum 400°C
- Designed for the assembly of chain slings where wide throat openings are necessary
- Before using the hook, check whether hooks without safety latches are allowed to be used for the particular application

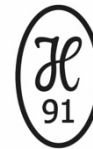

Certification:

Each unit comes fully certified with a test certificate or an EC Declaration of Conformity stating compliance with the essential health and safety requirements of the Machinery Directive 2006/42/EC, the Supply of Machinery (Safety) Regulations 2008 and Section 6 of the Health and Safety at Work Etc Act 1974.

Manufactured and tested in accordance with EN1677-1. All YOKE Lifting points meet or exceed all the requirements of ASME B30.26.

Technical Data

Product Code	Capacity (tonnes)	For Grade 100 Chain (mm)	Dimensions (mm)					Net Weight (kg)
			A	H	K	P	T	
X-046-07	2.5	7,8	10	30	133	62	20	0.95
X-046-10	4.0	10	12	35	162	74	29	1.8
X-046-13	6.7	13	15	39	180	88	32	3.6
X-046-16	10.0	16	18	46	216	101	41	6.4
X-046-20	16.0	20	24	59	279	116	57	11.2

Other sizes available - please ask for details.

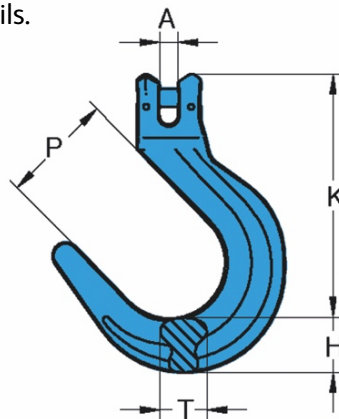

Due to our policy of continual product development, dimensions, weights and specifications may change without prior notice. Please check with your Tiger sales team when ordering.