

Digital Lifting Point - UNC Thread Model No. 8-212



Main Features

- Rotates through 360° and pivots 90°
- Manufactured from alloy steel, quenched and tempered
- Tested in accordance with EN1677-1
- Load rated parts are 100 % magnaflux crack detected
- Individual forged parts and cap screw are traceable to Test Certification
- Bolts are Metric thread
- Proof tested to 2.5 times the WLL
- Fatigue rated to 20,000 cycles at 1.5 times the WLL
- All YOKE Lifting points meet or exceed all the requirements of ASME B30.26
- Quick and simple assembly, just a tapped hole is required

Certification:

Each unit comes fully certified with a test certificate or an EC Declaration of Conformity stating compliance with the essential health and safety requirements of the Machinery Directive 2006/42/EC, the Supply of Machinery (Safety) Regulations 2008 and Section 6 of the Health and Safety at Work Etc Act 1974.

Manufactured and tested in accordance with EN1677-1. All YOKE Lifting points meet or exceed all the requirements of ASME B30.26.



Technical Data

Product Code	Capacity (tonne)	Thread version		TPI	Dimensions (inch)														Torque in (Nm)	Net Weight (lbs)
		M (inch)	E (inch)		A	B	C	D	F	G	H	S	SW	I	J	K	L	N		
8-212-010	1.0	1/2	0.94	13.0UNC	1.30	1.48	1.73	0.53	3.90	2.24	1.42	5/16	3/4	1.74	3.49	1.49	1.62	1.22	100	1
8-212-015	1.5	5/8	1.14	11.0UNC	1.30	1.48	1.81	0.53	3.90	2.24	1.42	3/8	15/16	1.76	3.49	1.47	1.56	1.22	150	1.3
8-212-020	2.5	3/4	1.46	10.0UNC	1.97	2.12	2.16	0.65	5.58	3.22	1.69	1/2	1 1/8	2.90	5.23	2.07	2.77	1.93	200	2.9
8-212-025	2.5	7/8	1.46	9.0UNC	1.97	2.12	2.24	0.65	5.58	3.22	1.69	5/8	1 5/16	2.90	5.23	2.07	2.69	1.93	250	2.8
8-212-040	4.0	1	1.61	8.0UNC	1.91	2.13	2.34	0.65	5.62	3.22	1.73	5/8	1 1/2	2.87	5.26	2.09	2.63	1.77	400	4.3
8-212-050	5.0	1 1/4	2.11	7.0UNC	2.36	2.56	3.21	0.89	6.70	3.90	2.42	7/8	1 7/8	3.14	6.00	2.53	2.60	2.32	500	6.8
8-212-080	8.0	1 1/2	2.44	6.0UNC	3.03	3.35	4.01	1.04	8.85	4.88	3.07	1	2 1/4	4.42	8.04	3.15	3.80	2.72	800	12.9

Other sizes available - please ask for details.

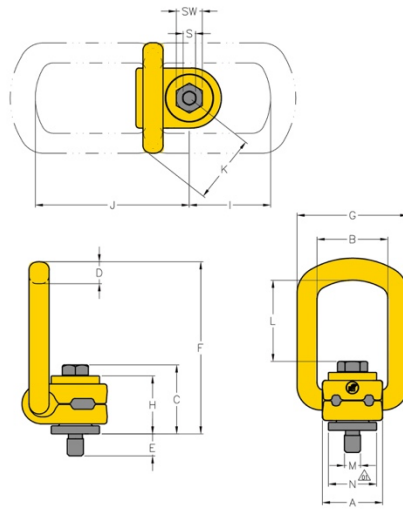

Kind of attachment

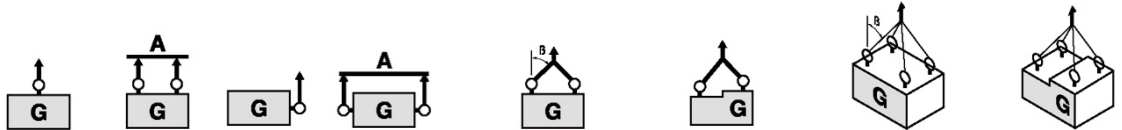

Number of legs	1	2	1	2	2	2	2	3-4	3-4	3-4	
Load direction	0°	0°	90°	90°	0-45°	45°-60°	unsymm.	0-45°	45°-60°	unsymm.	
Product Code	Thread	WLL (t)									
8-212-010	1/2	1.0	2	1.0	2	1.4	1.0	1.0	2.10	1.50	1.0
8-212-015	5/8	1.5	3	1.5	3	2.1	1.5	1.5	3.15	2.25	1.5
8-212-020	3/4	2.5	5	2.5	5	3.5	2.5	2.5	5.25	3.75	2.5
8-212-025	7/8	2.5	5	2.5	5	3.5	2.5	2.5	5.25	3.75	2.5
8-212-040	1	4.0	8	4.0	8	5.6	4.0	4.0	8.40	6.00	4.0
8-212-050	1 1/4	5.0	10	5.0	10	7.0	5.0	5.0	10.5	7.50	5.0
8-212-080	1 1/2	8.0	16	8.0	16	11.2	8.0	8.0	16.8	12.0	8.0

Due to our policy of continual product development, dimensions, weights and specifications may change without prior notice. Please check with your Tiger sales team when ordering.