

## Weld On Hook Model No. 8-081



### Main Features

- Manufactured from forged alloy steel, quenched and tempered
- Tested and certified by DGUV GS-OA-15-03
- Load rated parts are 100 % magnaflux crack detected
- Individual forged parts are traceable to Test Certification
- All YOKE Lifting points meet or exceed all the requirements of ASME B30.26
- WLL forged onto each product for quick and easy identification
- Lugs designed to assist the welding process



### Certification:

Each unit comes fully certified with a test certificate or an EC Declaration of Conformity stating compliance with the essential health and safety requirements of the Machinery Directive 2006/42/EC, the Supply of Machinery (Safety) Regulations 2008 and Section 6 of the Health and Safety at Work Etc Act 1974.

Manufactured and tested in accordance with EN1677-1. All YOKE Lifting points meet or exceed all the requirements of ASME B30.26.

### Technical Data

Product Code	Capacity (tonne)	Dimensions (mm)								Net Weight (kg)
		F	H	L	P	T	W	HV	a	
8-081-01	1.0	25	27	72	18	18	95	7	4	0.6
8-081-02	2.0	30	30	85	25	20	115	8	5	1.0
8-081-03	3.0	35	30	105	28	23	133	9	6	1.4
8-081-04	4.0	42	38	111	28	30	142	10	7	2.2
8-081-05	5.0	44	47	132	30	31	167	12	7	3.0
8-081-08	8.0	50	52	134	32	39	176	12	8	3.7
8-081-10	10.0	56	56	168	44	42	222	13	8	6.2
8-081-15	15.0	61	67	184	54	45	242	14	10	7.9

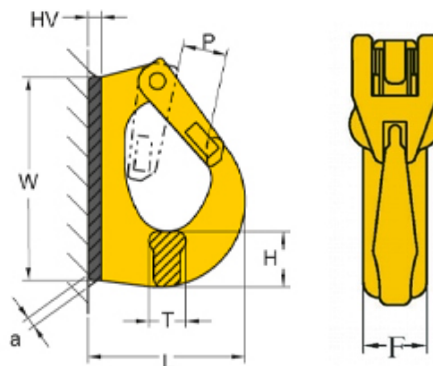

Due to our policy of continual product development, dimensions, weights and specifications may change without prior notice. Please check with your Tiger sales team when ordering.