

Bolt On Tie Down Model No. 8-058

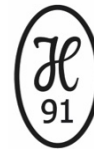

Main Features

- Pivots through 180° and allows side load lifting
- Manufactured from forged alloy steel, quenched and tempered
- Manufactured and tested in accordance with EN1677-1
- Load rated parts are 100 % magnaflux crack detected
- Individual forged parts are traceable to Test Certification
- Supplied without bolts; usage of Grade 10.9 or Grade 12.9 bolts is recommended
- Proof tested to 2.5 times the WLL
- All YOKE Lifting points meet or exceed all the requirements of ASME B30.26



Certification:

Each unit comes fully certified with a test certificate or an EC Declaration of Conformity stating compliance with the essential health and safety requirements of the Machinery Directive 2006/42/EC, the Supply of Machinery (Safety) Regulations 2008 and Section 6 of the Health and Safety at Work Etc Act 1974.

Manufactured and tested in accordance with EN1677-1. All YOKE Lifting points meet or exceed all the requirements of ASME B30.26.



Technical Data

Product Code	Capacity (tonne)	Dimensions (mm)									Bolt size	Net Weight (kg)
		A	B	D	F	H	K	L	N	R		
8-058-1T	1.0	50	72	14	27	55	98	139	14	24	M12	0.7
8-058-3T	3.0	58	84	17	34	53	114	147	18	29	M16	1.1
8-058-5T	5.0	64	117	22	46	74	160	206	23	33	M20/M22	2.5

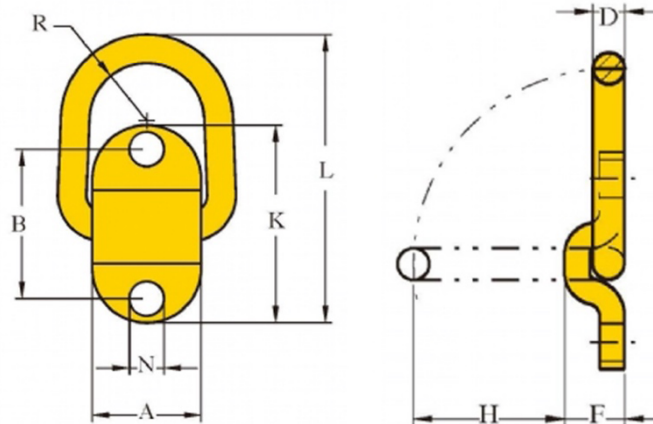

Due to our policy of continual product development, dimensions, weights and specifications may change without prior notice. Please check with your Tiger sales team when ordering.