

New 6t & 8t units available



Tiger ROV Chain Block

Main Features

- 3.0t, 6.0t, 8.0t, 10.0t, 15.0t, 20.0t and 30.0t capacity units available
- Fully corrosion protected
- Several choices of interface:
 - Hydraulic Hot Stab connection dual port type A and B
 - Rotary Torque Receptacle Classes 1,2 & 3
 - Manual D Handle, T-bar or Fishtail Direct Drive manual connection
 - QD Direct Drive Couplings
- Compliant with BS ISO 13628-8:2002 & BS ISO 13628-1:2005
- Stainless steel 316 framework and handle
- Proven Subsea brake design
- Patented Quad Cam pawl system – proven reliability
- One-piece brake chamber cover
- Heavy duty flexible chain bag or stainless steel chain bucket available as an option
- 4 Point manipulator connection points
- Compact and light weight
- Balanced design for easy handling and installation
- Marine specific friction discs
- New hand wheel feature for on-deck height of lift adjustments
- Bespoke chain lengths to meet exact customer requirements
- Full individual spares back up
- Each unit is fully tested and certified before delivery

User Manual/Certification:

Tiger chain blocks are sent out with a user manual which includes a test certificate or an EC Declaration of Conformity stating compliance with the essential health and safety requirements of the Machinery Directive 2006/42/EC. This document clearly states the proof test for the unit at 1.5 times the rated capacity on the 3.0t, 6.0t, 8.0t, 10.0t and 15.0t models and 1.25 times for the 20.0t and 30.0t models and the light load test of 2% of the rated capacity across the full range, which exceeds the requirements of the current applicable standard. Chain certification is included as part of this documentation.

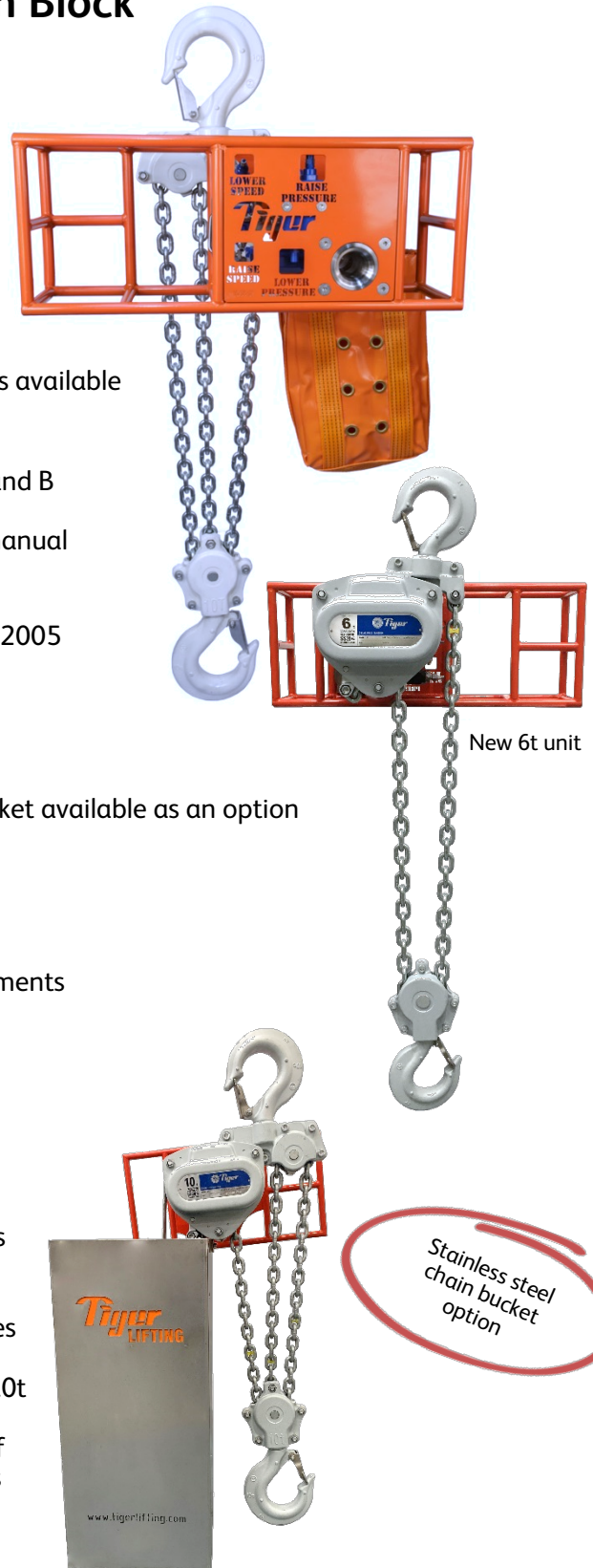

New 6t unit

Stainless steel chain bucket option

The Tiger ROV compatible chain block is available in various interface options all in accordance with BS ISO 13628-8:2002 ROV Interfaces on Subsea production systems. Tested and finished in accordance with Annexes B & K of BS ISO 13628-1:2005:

1. Hydraulic Hot Stab connection dual port type A and B
2. Rotary Torque Receptacle Classes 1,2 & 3
3. D Handle, T-bar or Fishtail Direct Drive manual connection
4. QD Direct Drive Couplings

Available as 3 tonne (single fall of load chain), 6 tonne (2 falls), 8 tonne (3 falls), 10 tonne (3 falls), 15 tonne (5 falls), 20 tonne single head (6 falls) and 30t twin head (10 falls) capacity chain blocks, chained up to project specific heights of lift (HOL) that can be pre-set to meet the exact starting point required within the rigging drawings.

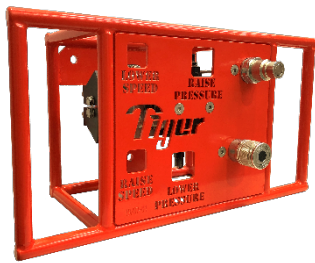

QD direct drive couplings



Manual D handle interface

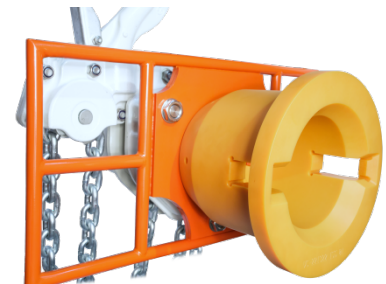

One of our torque receptacle options

Protection and Finish:

Critical internal components as are protected by our unique corrosion protection giving unprecedented long-term reliability. Stainless steel fittings are used throughout the hoist. These ensure the initial capital outlay of purchasing the hoist is protected by allowing the statutory inspections and re-certifications to be easier and also help with the overall aesthetics of the hoist being maintained in an “as new” condition. The integrated SS20 chain block is completed with a two-stage finish combining electroplating as a base layer and then finished with a very hard-wearing sand texture powder coating paint which offers excellent corrosion protection and high impact protection ideally suited for multi-immersion applications. Paint finish in accordance with ISO12944 C5M. Chain with extra corrosion protection is also available.

Hydraulic Hot Stab:

Working in partnership with Flexible Engineered Solutions Limited (FES) we have designed and built an ISO 13628-8 Fig 20 Type A & B Dual Port Hot Stab Female receptacle that is protected by our full 316 Stainless steel frame handle that has 4 built in connection points for the work class manipulators to hold and operate. This exclusively designed system makes for a well-balanced unit that sits perfectly when installing the unit within the project rigging. We use high quality dual direction check valves that prevent loss of the hydraulic fluid within the system when the hot stab is removed. These valves have a dual purpose as they ensure the minimal level of contamination to the system from sea water. We incorporate laser cut text for identification of hydraulic adjustments.

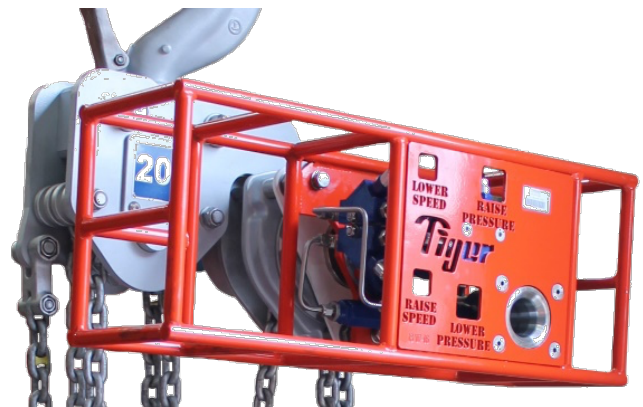



Stainless steel laser cut mounting frame



High performance marine spec hydraulic system

QD Direct Drive Couplings:

The QD interface is supplied with a female and male 3/4 BSP ISO 16028 flat face, radial ball locking quick connect coupler set that provides fast and efficient hydraulic connection, allowing the hoist to be controlled from the deck HPU. The QD interface is complete with the same equipment as the hot stab interface but is far more compact in design for areas with reduced access. The interface is protected by our full 316 stainless steel frame handle that has 4 built in connection points for the work class manipulators to hold and operate. This exclusively designed system makes for a well-balanced unit that sits perfectly when installing the unit within the project rigging.

Rotary Torque Tool:

This interface has been designed to meet the exact requirements of BS ISO 13628-8:2002. These units can be supplied in Classes 1+2 or class 3 giving maximum tooling flexibility whilst only requiring an operational torque of 50Nm to lift 20 tonnes.

D Handle, T-bar or Fishtail Manual Direct Drive:

Using the same guard frame as the torque tool interface built from 316L stainless steel giving maximum protection, this option gives a very flexible operator-friendly interface by incorporating a high strength but flexible compliance joint making for a very positive and reliable direct drive mechanism.

Stainless Steel Frame Handle:

All our interface options come mounted in our purpose built high strength frames that are constructed using 316L stainless steel bar and tubing, ensuring full compliance with BS ISO 13628-8:2002(E) which gives the manipulators four T-Bar connection positions to hold onto (see below) and these tie in with T slots found in parallel jaw manipulators. All welds are continuous and all edges sealed to prevent corrosion. Frames have laser cut text for identification of hydraulic adjustments. Frames are painted RAL 2002 orange as per ISO 13628-1 to signify ROV grab point.

Subsea Brake:

Developed and designed for Subsea use creating a highly efficient, reliable braking surface for use in the most extreme conditions. Incorporates our patented Quad Cam Pawl System.

Chain Guides:

Specifically designed to guide the load chain safely onto or off the load sheave without snagging or jamming, the fluted chain stripper ensures unrestricted entry and exit of the calibrated load chain.

Optional Chain Carriers:

Designed to carry and hold the length of load chain required for the operation. These chain carriers prevent loose chain from getting snagged during lifting or lowering operations and protect any loose chain during transit to and from the operational site.

Chain Bags:

Incorporating a stainless steel frame work and heavy duty PVC flexible bag reinforced by webbing with eyelet drain holes for an easy transfer through the splash zone.

Chain Buckets:

Our new design of stainless steel chain bucket is available in different size options. With drain holes side and bottom, they are a robust alternative to a chain bag.

Hooks:

Our hooks incorporate our patented “EZ Check” feature which allows operators and inspection engineers to easily check to see if the hoist has been previously overloaded or shock loaded by simply measuring between the triangle of pop marks.

Our drop forged and heat-treated alloy hooks are furnished with heavy duty spring latch kits that fully engage into the recessed nose of the hook safeguarding the load when side loading of the latch occurs and offering maximum load security. The swivel hooks are attached to the yoke using high grade nuts & bolts allowing for complete inspection during any statutory inspection or written scheme maintenance.



The entire hook fitting has been protected using corrosion protected or stainless steel fixtures and fittings. Our latest latches incorporate a new wing design making them easier to operate in the operation area (e.g. wet gloved hands for offshore or subsea use).

Available with hooks that swivel under the full working load limit, to meet relevant standards i.e. AS 1418.2. Also available with spark resistant hooks.

High Performance Premium Grease:

We use new technology, wide temperature range, high performance premium grease. It contains no heavy metals or other harmful additives making it more environmentally friendly. This selection achieves the correct viscosity to prevent the grease migrating from the area of application. Even when mixed with 50 % high water absorption it has excellent adhesion and no sign of breakdown after 100,000 strokes and remains unchanged with no slump or breakdown unlike other “premium” greases. Load carrying ability, mechanical stability, corrosion protection, water resistance and increased operating temperature ranges are all improved by the using only the very best lubricant.

Hydraulic Specification:

Hydraulic Interface: ISO 13628-8 Fig 20 Type A & B Dual Port Hot Stab Female.

Recommended Hydraulic Fluid: Hydraulic Mineral oil AWS 22 or 32 or similar.

Hydraulic Supply: 210bar Maximum (via ROV or Deck Powerpack) Guide flow rate 4 to 8 litres per minute. Danfoss 80cc hydraulic motor. Painted stainless steel mount frame. Manufacturer coated steel motor. Stainless steel hydraulics. Stainless steel fastenings.





Hand Wheel:

Recent innovation to meet client requirements saw the addition of a hand wheel on our ROV operated chain blocks to allow for on-deck height of lift adjustments.



Quality Machining:

Our strong impact resistant gearbox housing is complete with close tolerance fit phosphor bronze bushing that fully supports the pinion shaft and gears to maintain smooth revolutions whilst under load. Ideally suited for offshore and marine environments.

The subsea suitable bearings for top and bottom hook load sheaves are enclosed in drop forged housings assembled with stainless steel fittings.

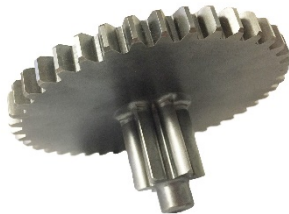

One Piece Construction Pinion Gears:

SS20 gearboxes for Tiger ROV chain blocks contain one-piece pinion gears. This revolutionary process in gear manufacturing uses drop-forged raw material, precision machined and heat treated with precise ratios between teeth and body.

Available with Adaptor Components:

Drop forged adaptor maintaining maximum strength. 360° Rotation and 180° Pivot for Maximum Flexibility. Tested and certified to 4:1 factor of safety.

Tiger clevis shackle or reeveable egg (master) link available for units up to 10t capacity or alternatively the hoist can be customised for alternative fittings for all capacities.



Please see our Tiger Corrosion Resistant Chain Block SS20 technical sheet for more information about the chain block.



Also available with RUD ROV hooks

Due to our policy of continual product development, dimensions, weights and specifications may change without prior notice. Please check with your Tiger sales team when ordering.

Bespoke designs available on request – contact info@tigerlifting.com for more information.

Technical Information

| Product Code | Capacity (tonne) | Max Torque (Nm) | Revs per 300mm travel (max 125 RPM) | Time to raise 300mm at max RPM (Min:Sec) | Mass out of Water (Kg) (Includes chain block @ std HOL) | | | |
|--------------|------------------|-----------------|-------------------------------------|--|---|----------|--------------|-------------------|
| | | | | | Hot Stab | QD Drive | Torque Viper | Fishtail/D-handle |
| RCB-0300 | 3.0 | 45 | 55 | 0:26 | 72.5 | 54.5 | 57.5 | 43.0 |
| RCB-0600 | 6.0 | 46 | 110 | 0:59 | 87.5 | 69.5 | 72.5 | 58.0 |
| RCB-0800 | 8.0 | 47 | 165 | 1:19 | 103.0 | 85.0 | 88.0 | 73.5 |
| RCB-1000 | 10.0 | 50 | 165 | 1:19 | 106.0 | 84.5 | 87.5 | 76.0 |
| RCB-1500 | 15.0 | 52 | 275 | 2:12 | 170.5 | 154.5 | 157.5 | 141.0 |
| RCB-2000 | 20.0 | 55 | 340 | 2:43 | 220.5 | 202.0 | 205.0 | 190.5 |
| RCB-3000 | 30.0 | 62 | 570 | 4:34 | 347.0 | 331.0 | 334.0 | 319.0 |

Chain Block Data

| Product Code | Capacity (tonne) | Effort (kg) | Dimensions (mm) | | | | | | | Load Chain | | Standard HOL (m) | Mass @ std HOL (kg) | Mass for extra metre HOL (kg) |
|--------------|------------------|-------------|-----------------|-----|------|-----|-----|----|-----|---------------|--------------|------------------|---------------------|-------------------------------|
| | | | A | B | C | D | E | F1 | F2 | Diameter (mm) | No. of falls | | | |
| SCB-0300 | 3.0 | 38 | 109 | 84 | 550 | 98 | 157 | 36 | 56 | ∅10.0 | 1 | 3 | 30.5 | 3.2 |
| SCB-0600 | 6.0 | 38 | 109 | 84 | 635 | 86 | 220 | 49 | 70 | ∅10.0 | 2 | 3 | 45.5 | 5.3 |
| SCB-0800 | 8.0 | 34 | 109 | 84 | 610 | 153 | 263 | 51 | 78 | ∅10.0 | 3 | 3 | 61.0 | 7.5 |
| SCB-1000 | 10.0 | 40 | 109 | 84 | 660 | 153 | 263 | 54 | 87 | ∅10.0 | 3 | 3 | 64.0 | 7.5 |
| SCB-1500 | 15.0 | 41 | 109 | 84 | 840 | 225 | 378 | 59 | 81 | ∅10.0 | 5 | 3 | 128.5 | 11.8 |
| SCB-2000 | 20.0 | 43 | 161 | 90 | 1050 | 148 | 360 | 81 | 110 | ∅10.0 | 6 | 3 | 178.5 | 14.2 |
| SCB-3000 | 30.0 | 42 | 220 | 220 | 1200 | 388 | 388 | 91 | 135 | ∅10.0 | 10 | 3 | 307.0 | 23.8 |

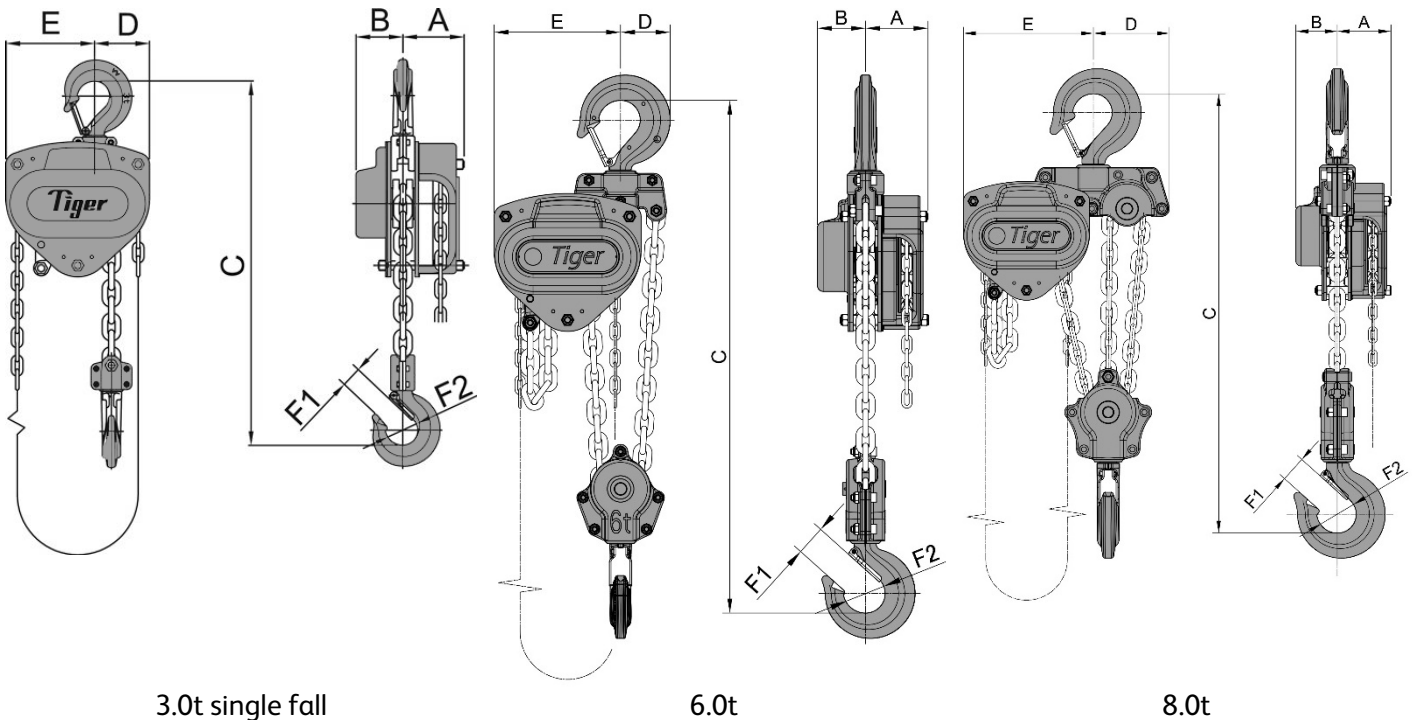

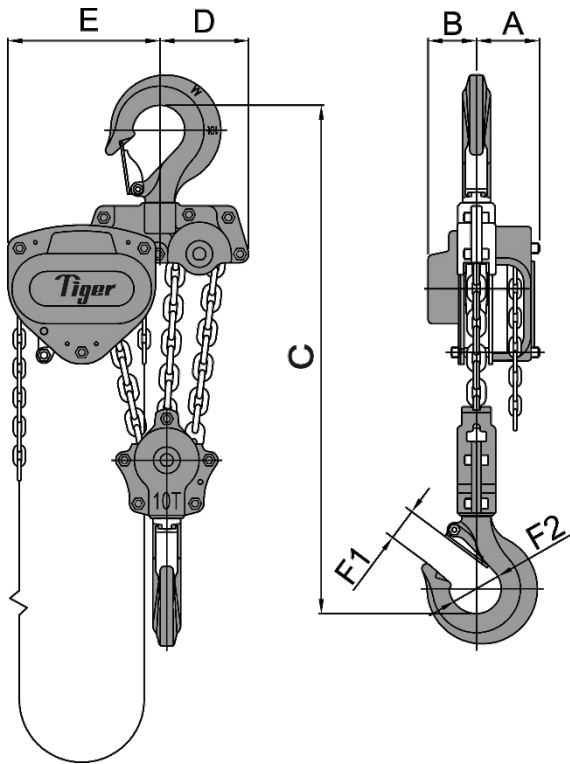

10.0t

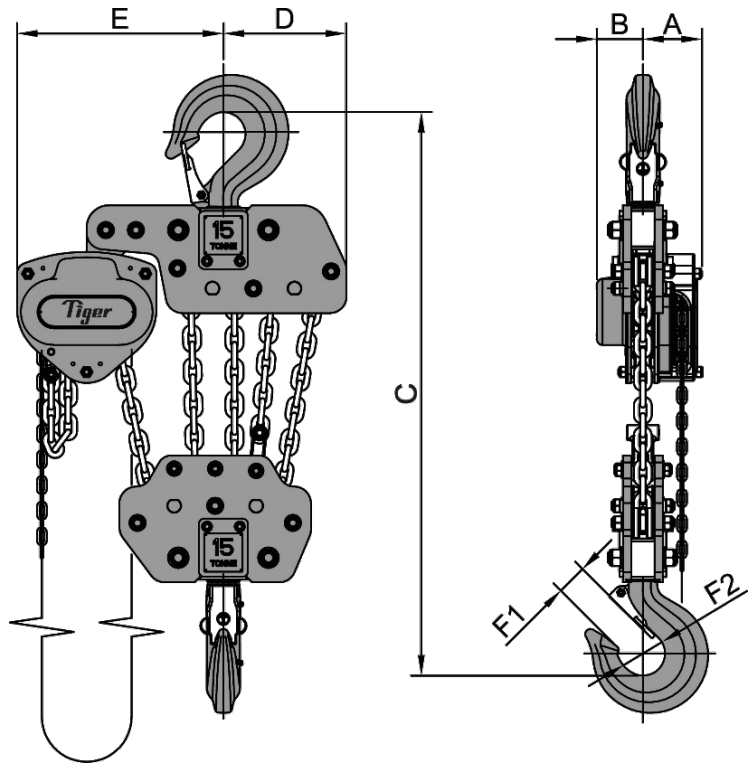

15.0t

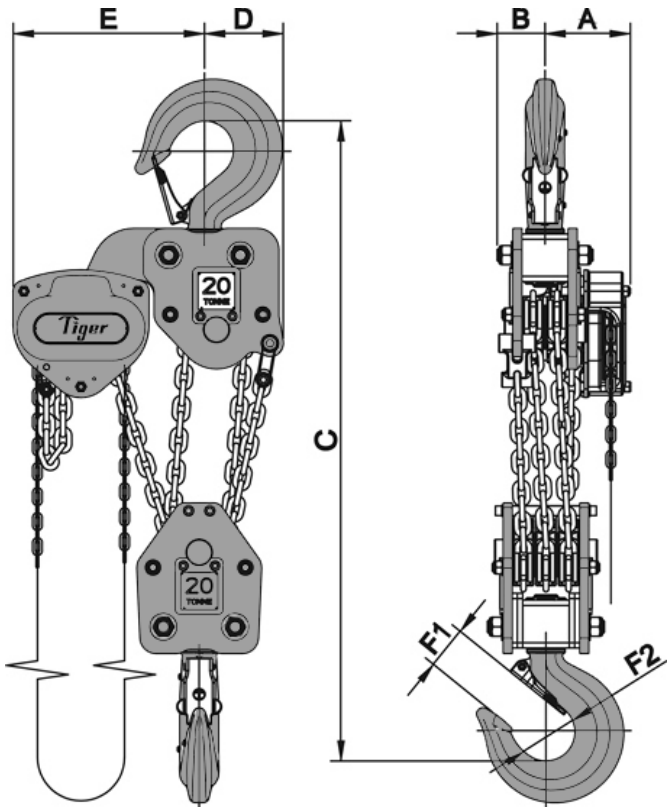

20.0t

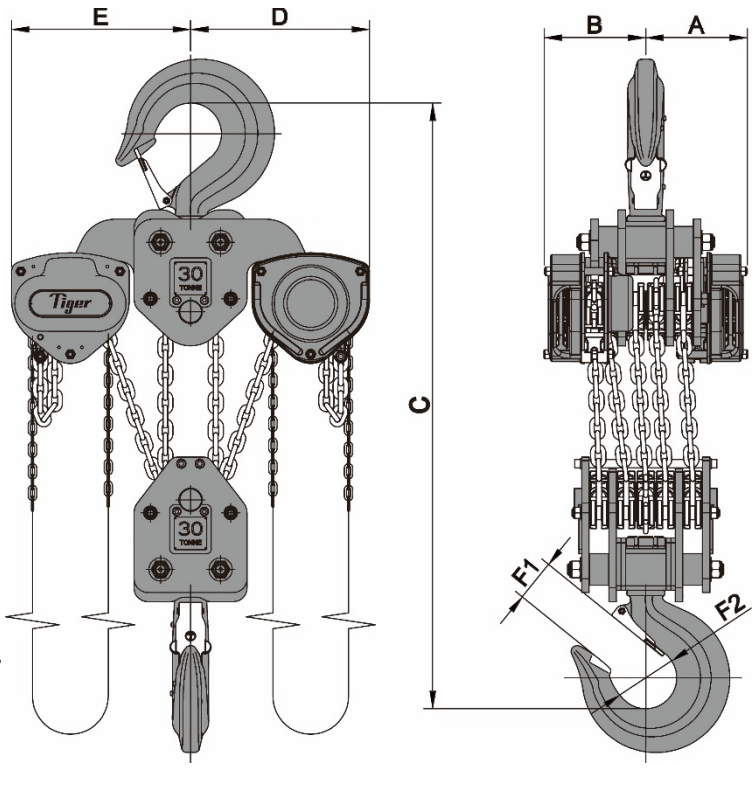

30.0t

ROV Chain Block with D Handle

| Product code | Dimensions (mm) | | | | | | | | | |
|--------------|-----------------|-----|------|-----|-----|----|-----|-----|-----|-----|
| | A | B | C | D | E | F1 | F2 | G | H | M |
| RCB-030D | 221 | 84 | 550 | 280 | 310 | 36 | 56 | 309 | 405 | 504 |
| RCB-060D | 221 | 84 | 703 | 221 | 369 | 49 | 70 | 309 | 467 | 504 |
| RCB-080D | 221 | 84 | 749 | 179 | 411 | 51 | 78 | 309 | 489 | 504 |
| RCB-100D | 221 | 84 | 660 | 185 | 405 | 54 | 87 | 309 | 515 | 504 |
| RCB-150D | 221 | 84 | 840 | 225 | 520 | 59 | 81 | 309 | 570 | 504 |
| RCB-200D | 221 | 90 | 1050 | 148 | 515 | 81 | 110 | 309 | 650 | 510 |
| RCB-300D | 332 | 220 | 1200 | 388 | 545 | 91 | 135 | 309 | 680 | 750 |

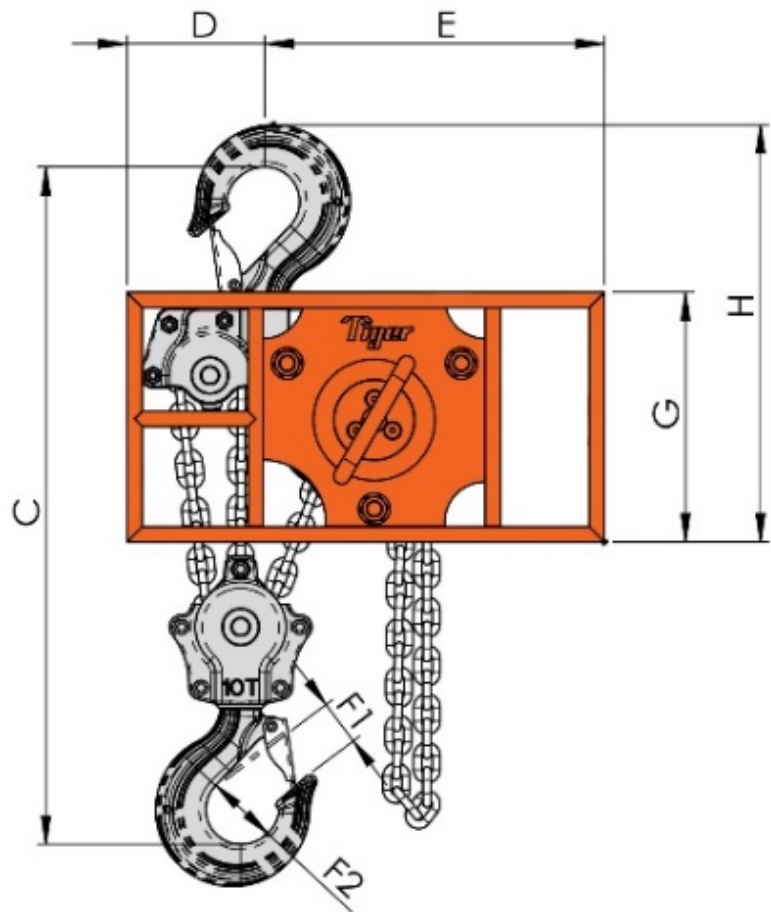
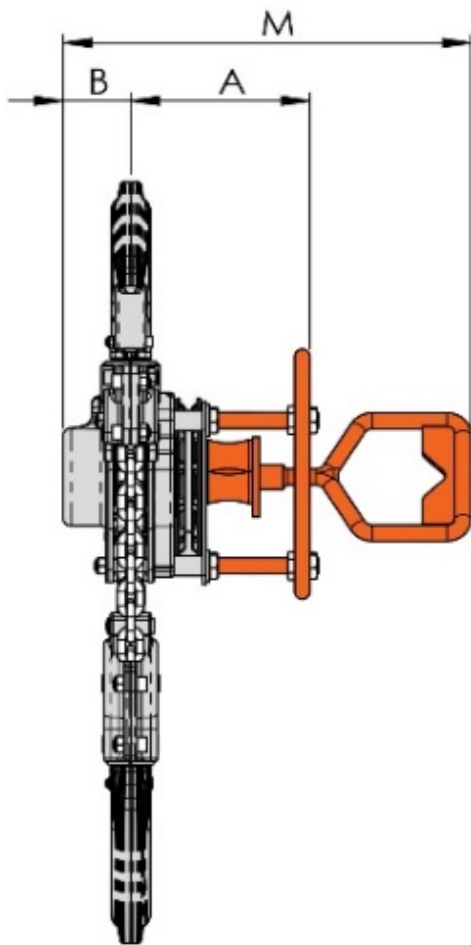

ROV Chain Block with Fishtail

| Product code | Dimensions (mm) | | | | | | | | | |
|--------------|-----------------|-----|------|-----|-----|----|-----|-----|-----|-----|
| | A | B | C | D | E | F1 | F2 | G | H | M |
| RCB-030F | 221 | 84 | 550 | 280 | 310 | 36 | 56 | 309 | 405 | 536 |
| RCB-060F | 221 | 84 | 703 | 214 | 376 | 49 | 70 | 309 | 467 | 536 |
| RCB-080F | 221 | 84 | 749 | 179 | 411 | 51 | 78 | 309 | 189 | 536 |
| RCB-100F | 221 | 84 | 660 | 185 | 405 | 54 | 87 | 309 | 515 | 536 |
| RCB-150F | 221 | 84 | 840 | 225 | 520 | 59 | 81 | 309 | 570 | 536 |
| RCB-200F | 221 | 90 | 1050 | 148 | 515 | 81 | 110 | 309 | 650 | 542 |
| RCB-300F | 332 | 220 | 1200 | 388 | 545 | 91 | 135 | 309 | 680 | 780 |

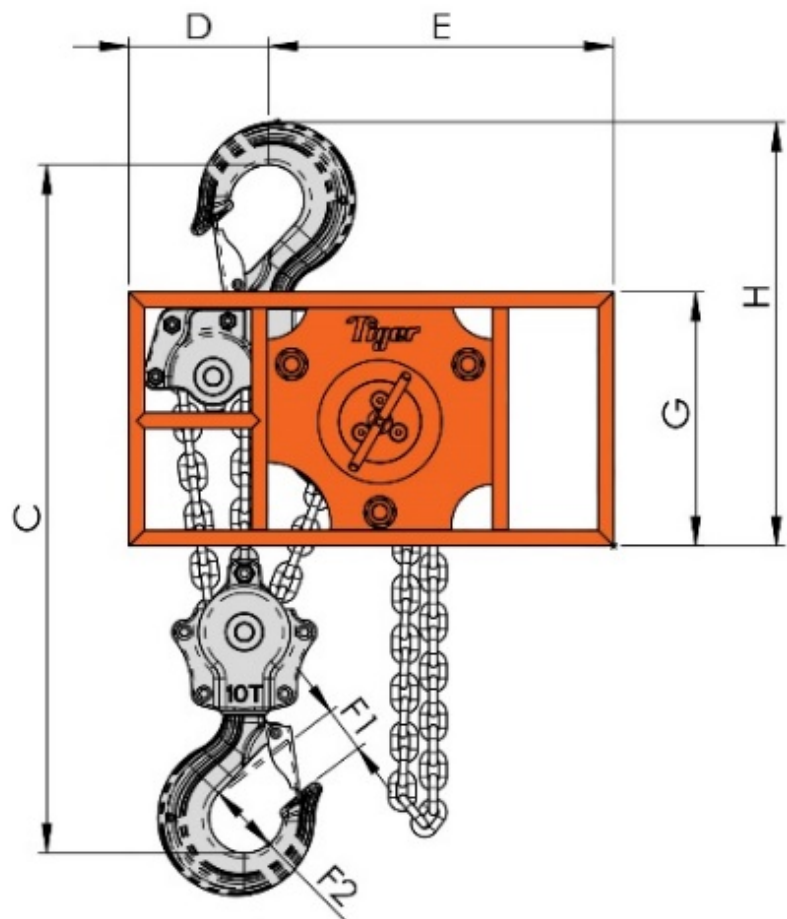
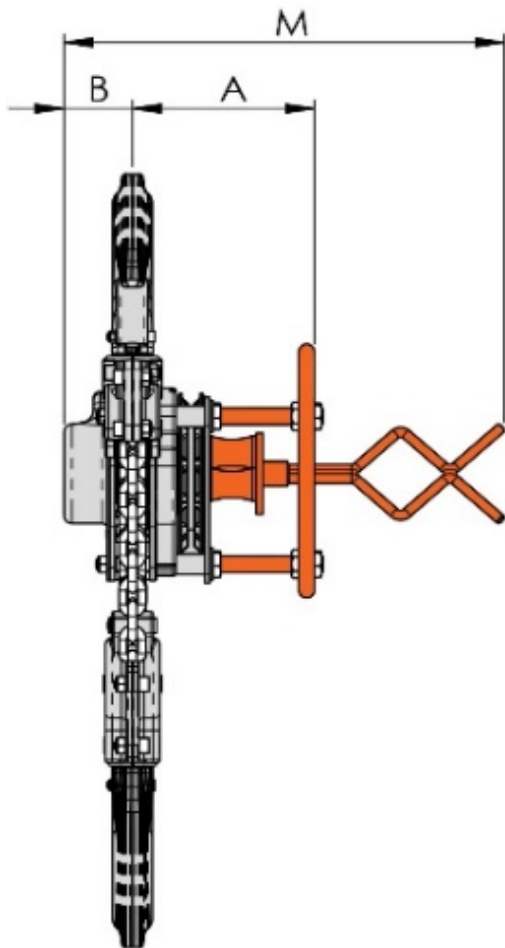

ROV Chain Block with Rotary Torque

| Product code | Dimensions (mm) | | | | | | | | | |
|--------------|-----------------|-----|------|-----|-----|----|-----|-----|-----|-----|
| | A | B | C | D | E | F1 | F2 | G | H | M |
| RCB-030T | 106 | 84 | 550 | 280 | 310 | 36 | 56 | 309 | 405 | 390 |
| RCB-060T | 106 | 84 | 703 | 214 | 376 | 49 | 70 | 309 | 467 | 390 |
| RCB-080T | 106 | 84 | 749 | 179 | 411 | 51 | 78 | 309 | 489 | 390 |
| RCB-100T | 106 | 84 | 660 | 185 | 405 | 54 | 87 | 309 | 515 | 390 |
| RCB-150T | 106 | 84 | 840 | 225 | 520 | 59 | 81 | 309 | 570 | 390 |
| RCB-200T | 158 | 90 | 1050 | 148 | 515 | 81 | 110 | 309 | 650 | 448 |
| RCB-300T | 216 | 220 | 1200 | 388 | 545 | 91 | 135 | 309 | 680 | 636 |

A/M measurements are for our Viper Rotary Torque option (as shown in diagram below and this image)

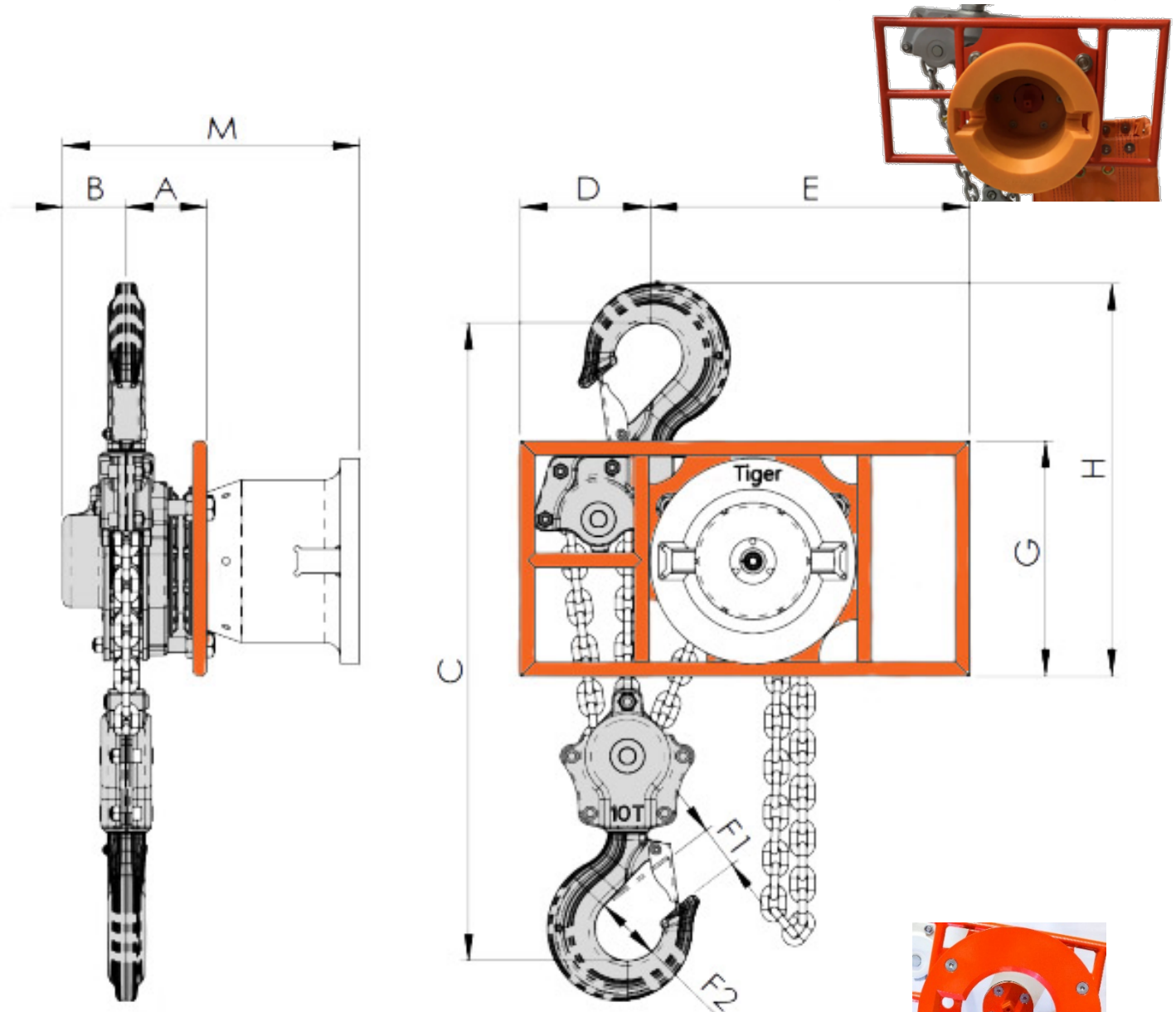

An alternative **Rotary** Torque option is available (as shown in image to the right).
 Please contact us for details
ROV Chain Block with Hot Stab

| Product code | Dimensions (mm) | | | | | | | | |
|--------------|-----------------|-----|------|-----|-----|----|-----|-----|-----|
| | A | B | C | D | E | F1 | F2 | G | H |
| RCB-030H | 374 | 84 | 550 | 420 | 280 | 36 | 56 | 273 | 420 |
| RCB-060H | 374 | 84 | 703 | 354 | 346 | 49 | 70 | 273 | 482 |
| RCB-080H | 374 | 84 | 749 | 320 | 380 | 51 | 78 | 273 | 503 |
| RCB-100H | 374 | 84 | 660 | 300 | 400 | 54 | 87 | 273 | 530 |
| RCB-150H | 374 | 84 | 840 | 225 | 510 | 59 | 81 | 273 | 570 |
| RCB-200H | 374 | 90 | 1050 | 200 | 500 | 81 | 110 | 273 | 700 |
| RCB-300H | 485 | 220 | 1200 | 388 | 495 | 91 | 135 | 273 | 695 |

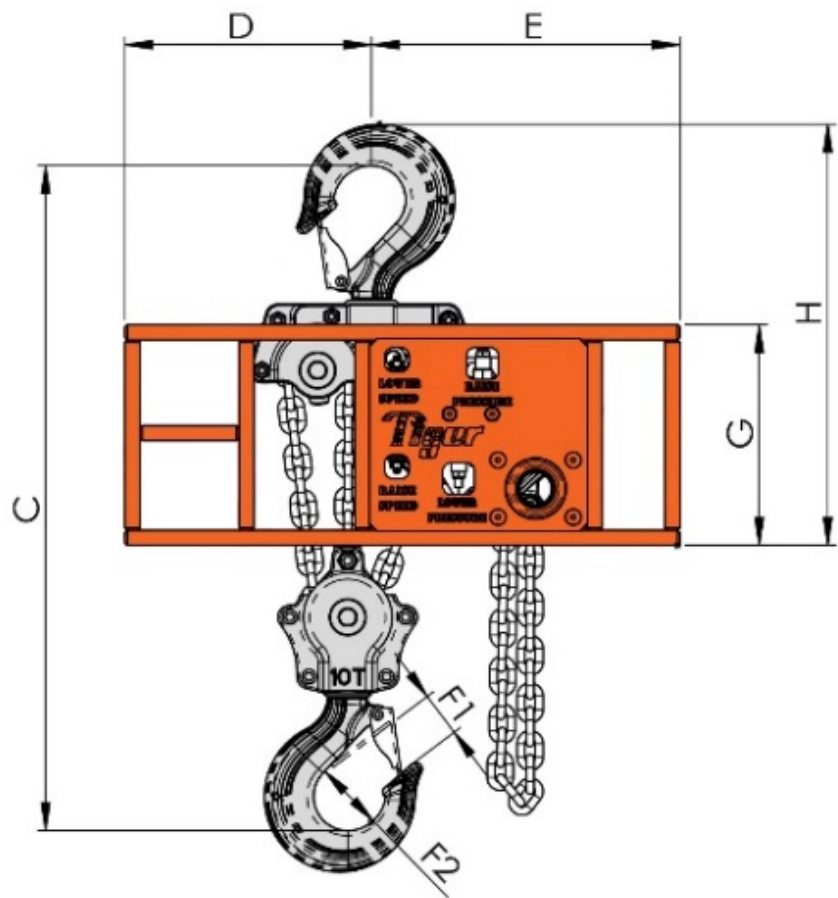
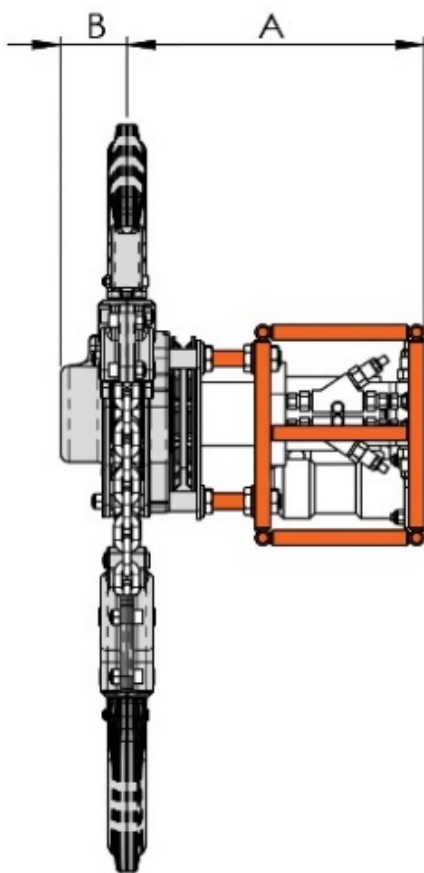

ROV Chain Block with QD Drive

| Product code | Dimensions (mm) | | | | | | | | |
|--------------|-----------------|-----|------|-----|-----|----|-----|-----|-----|
| | A | B | C | D | E | F1 | F2 | G | H |
| RCB-030H-QD | 374 | 84 | 550 | 228 | 280 | 36 | 56 | 273 | 420 |
| RCB-060H-QD | 374 | 84 | 703 | 162 | 346 | 49 | 70 | 273 | 481 |
| RCB-080H-QD | 374 | 84 | 749 | 162 | 380 | 51 | 78 | 273 | 503 |
| RCB-100H-QD | 374 | 84 | 660 | 153 | 400 | 54 | 87 | 273 | 530 |
| RCB-150H-QD | 374 | 84 | 840 | 225 | 510 | 59 | 81 | 273 | 570 |
| RCB-200H-QD | 374 | 90 | 1050 | 148 | 500 | 81 | 110 | 273 | 700 |
| RCB-300H-QD | 485 | 220 | 1200 | 388 | 515 | 91 | 135 | 273 | 695 |

