

Tiger Lever Hoists with Shipyard Hooks



Our Tiger PROLH Lever Hoists are now available with shipyard hooks.

Shipyard hooks are available in 1.6t & 3.2t capacities. They are optional top or bottom hooks that are designed specifically for Tiger lever hoist applications where point loading of the hook is possible.

Our drop forged and heat-treated alloy shipyard hooks are furnished with heavy duty spring latch kits. The swivel hooks are attached to the yoke using high grade nuts & bolts allowing for complete inspection during any statutory inspection or written scheme maintenance. Our hooks incorporate our patent protected “EZ Check” feature which allows operators and inspection engineers to easily check to see if the hoist has been previously overloaded or shock loaded by simply measuring between the triangle of pop marks.

PROLH lever hoists incorporate many of the advanced safety features that Tiger has developed including one-piece construction pinion gears and our patented Quad Cam Pawl System. These units meet and exceed all the requirements within BS EN 13157: 2004+A1:2009, ANSI/ASME B30.21, AS1418.2 and SANS 1636.

The PROLH is ideally suited for applications in the overhead transmission industry, shipyards and offshore platforms and is also suitable for underground mining use.

The PROLH includes our unique rotational inertia driven torsion switch brake and freewheeling system. This Tiger brake system is now a proven design with many thousands of hours of empirical evidence as proof of design and efficiency.

This design removes the need for inefficient old-style longitudinal disengagement methods of pulling the brake system apart to facilitate freewheeling. This highly efficient method of operating is not only safer but easier for the operator whilst measurably increasing the brake take up efficiency rate.

With over 50 years of professional manufacturing experience, Tiger’s commitment to innovation and customer satisfaction mean we will continue to develop and improve our products by communicating and working with our customers.



Please see our PROLH page for more information.

Technical Data

| Product Code | Capacity (tonne) | Effort (kg) | Dimensions (mm) | | | | | | | Load Chain | | Standard HOL (m) | Mass @ std HOL (kg) | Mass for extra metre HOL (kg) |
|--------------|------------------|-------------|-----------------|-----|-----|-----|-----|----|----|---------------|--------------|------------------|---------------------|-------------------------------|
| | | | A | B | C | D | E | F1 | F2 | Diameter (mm) | No. of falls | | | |
| PLH-0160 | 1.6 | 28 | 154 | 360 | 320 | 172 | 104 | 27 | 38 | ∅7.1 | 1 | 1.5 | 10.5 | 1.1 |
| PLH-0320 | 3.2 | 40 | 182 | 360 | 420 | 195 | 108 | 38 | 50 | ∅10.0 | 1 | 1.5 | 18.0 | 2.2 |

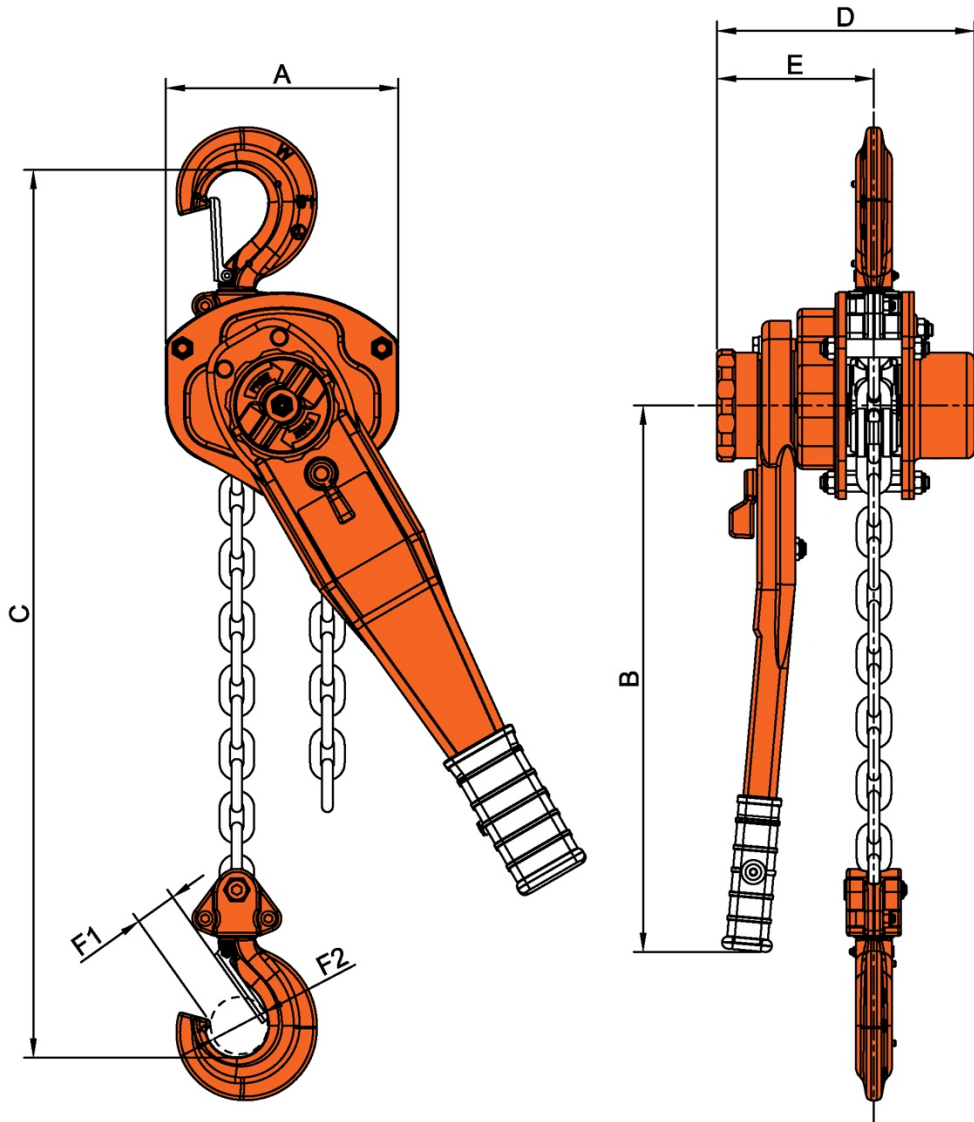

Due to our policy of continual product development, dimensions, weights and specifications may change without prior notice. Please check with your Tiger sales team when ordering.

Bespoke designs available on request – contact info@tigerlifting.com for more information.