



PROCB14  
the new name for the  
TCB14

## Tiger Chain Block Model No. PROCB14

go digital!

### Main Features

- DNV GL Verification tested according to NORSOK R-002
- Range from 250kg – 35.0t
- Available with slipping clutch overload protection
- Tested and certified for “fleeting”, “drifting” and “cross-hauling” applications up to 60° from the vertical without deration
- Available with forged clevis adaptor components
- Patented Quad Cam Pawl System
- Light load tested and certified at 2% of the rated capacity
- Rugged steel body construction yet lightweight and portable
- Double cover protection for brake chamber
- Drop forged & heat-treated alloy hooks
- High quality alloy calibrated load chain
- Heat treated alloy steel triple spur gears and pinion shaft
- Operating temperature of -40°C to +80°C
- Proof tested to 1.5 times rated capacity
- Can be chained to any height of lift to meet your exact requirements
- Individual spares readily available
- Suitable for underground mining use
- Also available with stainless steel load chain – any capacity over 1t deration will apply
- Available with load bearing swivel hooks to meet relevant standards e.g. AS 1418.2
- Meets or exceeds all international standards
- Available with a digital RFID tag, supported by RiConnect

RiConnect



The PROCB is manufactured from the highest quality steel materials precisely machined in our own factory, offering a lightweight, compact and rugged construction, producing an exceptionally strong product resistant to impact damage. The especially low headroom allows for easy installation in the most restricted environments. The unique design features - including our patented Quad Cam Pawl System - give it significant safety advantages over standard chain blocks and make the PROCB chain block the ideal tool for long term use with low maintenance and servicing costs.

These units meet and exceed all the requirements within BS EN 13157: 2004+A1:2009, ANSI/ASME B30.16, AS 1418.2 and SANS 1594.

Our patented Quad Cam Pawl System guarantees permanent engagement of at least one of the two reciprocating cam pawls fitted to the PROCB, ensuring the pawl only just clears the ratchet wheel, with the minimum of clearance as required under BS 4898:1973. But most importantly, in the unlikely event of a pawl spring failure, this design will ensure the brake is still fully functional and the load is sustained without damage to the mechanism.

Key design features such as our patented brake pawls and deep pocket design hand wheel along with the full and comprehensive testing regime we have submitted our PROCB hoist to provide the evidence that allows us to state that these units can be safely used for “fleeting”, “drifting” and “cross-hauling” applications up to 60° from the vertical without deration.

Tiger uses an 8 point multi start thread pinion shaft which has also increased brake reaction times.

**Our innovation, your safety**

### Certification:

Each unit comes fully certified with a test certificate or an EC Declaration of Conformity stating compliance with the essential health and safety requirements of the Machinery Directive 2006/42/EC. This document clearly states the proof test at 1.5 times the rated capacity and the light load test of 2 % of the rated capacity, which exceeds the requirements of the current applicable standard.

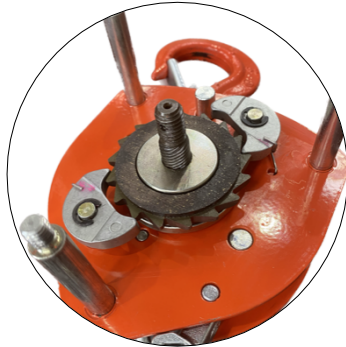

### Patent Protected Quad Cam Brake Pawl System:

This patented development in brake efficiency guarantees permanent engagement of at least one of the two reciprocating cam pawls fitted to the PROCB, ensuring the pawl only just clears the ratchet wheel, with the minimum of clearance as required under BS 4898:1973. But most importantly, in the unlikely event of a pawl spring failure, this new design will ensure the brake is still fully functional and the load is sustained without damage to the mechanism.

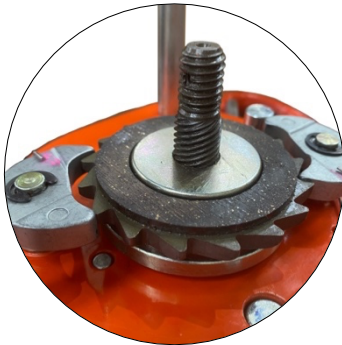

### Brake Efficiency:

Tiger uniquely uses an 8 point multi start thread pinion shaft which doubles the lead distance compared with typical 4 point threaded shafts, increasing the brake efficiency by 100 %.



### Chain End Stops:

Will hold a load of at least 2.5 times the rated capacity when supporting the full load without restraint from other components e.g. brake or gearing as required in many international standards. This prevents accidents, by acting as a stop when the lift length of the load chain is exceeded when lowered.



### Overload Protection:

If the chain block is fitted with a slipping clutch overload mechanism then it is protected from overload. When the load limit is exceeded, the clutch in the chain wheel will slip, allowing the hand wheel to be rotated whilst not engaging the gear box. This prevents further lifting of the load, though lowering is still possible. The PROCB with overload protection is DNV GL Verification tested according to NORSOK R-002.

### Safety Brake:

The highly efficient and fully corrosion protected brake system works instantly when the operation is stopped and securely holds the load. Loads are lowered under perfect control, allowing for precise operations. The PROCB easily passes the “brake lock out test” as per BS 3243:1990 with a 2% load of the rated capacity.

### Lifting at Angles:

The PROCB range of chain blocks fitted with the patented protected Quad Cam Brake System has undergone a full and comprehensive testing regime that was drawn up by industry specialists and Tiger’s mechanical engineers to provide evidence that these units can be safely used for “fleeting”, “drifting” and “cross-hauling” applications up to 60° from the vertical without deration. **Note:** All such operations should be carried out in accordance with manufacturer’s instructions and fully risk assessed by a competent person.

With a conventional twin pawl brake mechanism (teardrop design) failure can occur if the pawl spring erodes, fractures or a shock load bounces the pawls out of the ratchet gear. Without the spring these systems rely on gravity keeping the pawls engaged and are flawed when the hoist is used at angles away from the vertical.

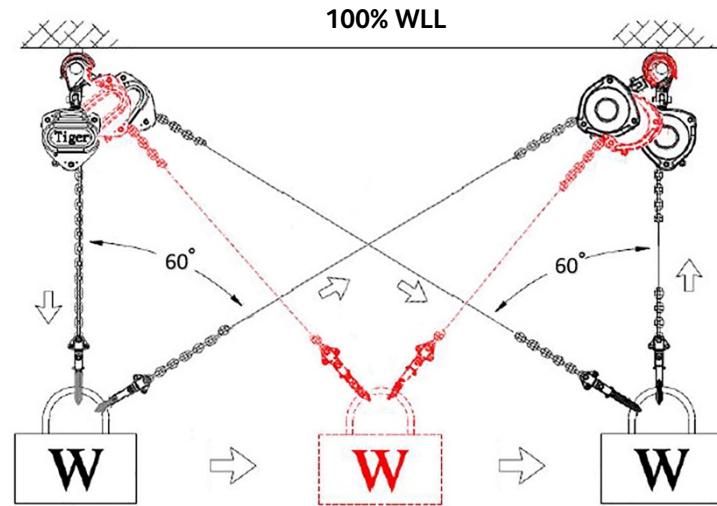

### Hand Wheel:

For chain blocks to be used up to an angle of 60 degrees, it’s critical that the hand chain leaves and enters the hand wheel without twisting, snagging or jamming. Thanks to our specially designed deep-profile chain block hand wheel this is achievable as it helps to seat the chain no matter what angle or direction of pull.



### Adaptor Components:

Drop forged adaptor maintaining maximum strength. 360° Rotation and 180° Pivot for Maximum Flexibility. Tested and certified to 4:1 factor of safety.



Self-locking (safety) hook, clevis shackle, reeveable egg (master) link or sling hook fittings available (for units up to 10t capacity).





### Hooks:

Our hooks incorporate our patented “EZ Check” feature which allows operators and inspection engineers to easily check to see if the hoist has been previously overloaded or shock loaded by simply measuring between the triangle of pop marks.

Our drop forged and heat treated alloy hooks are furnished with heavy duty spring latch kits that fully engage into the recessed nose of the hook safeguarding the load when side loading of the latch occurs and offering maximum load security. The swivel hooks are attached to the yoke using high grade nuts & bolts allowing for complete inspection during any statutory inspection or written scheme maintenance.

Available with hooks that swivel under the full working load limit, to meet relevant standards i.e. AS 1418.2. Also available with spark resistant hooks.



### Forgings:

Recessed hook yoke forgings offer full protection to the load chain anchor bolts on all our bottom hooks.

Precise tolerances in the bottom hook yokes means foreign objects are restricted from entering the load sheave area and chain can't get twisted.



### Combination Trolley and Block:

The top hook can be replaced by a competent person so the PROCB can be directly fitted to our beam trolley range of the equivalent capacity achieving the lowest possible headroom.

**Temperature Range:**

Standard operating temperature range -40°C to +80°C - far exceeding the requirements of current standards. Ultra-low operating temperature units (-60°C to +80°C) also available.

**Load Chains:**

Tiger only use the highest quality alloy, calibrated load chains in Grade T or VH conforming to EN818-7 and ISO 16872. Our hoists are also available with stainless steel load chain.

**Mechanical Efficiency:**

All major components are heat treated and precisely machined to ensure long term smooth operation. High gear ratios keep physical effort to a minimum.

**Chain Carriers:**

Available with chain bag as an option.

**Entertainment Rigging:**

Available in black finish for the entertainment industry.

**Double Cover Protection:**

Both the hand chain wheel cover and the ratchet brake cover are designed to offer protection to the brake chamber in the harshest environments from foreign objects.

**Finish:**

The PROCB is finished in our high-quality powder coat paint offering excellent corrosion protection.

**Performance:**

The PROCB has undergone a full test program that includes:

Type Testing

- Ultimate strength test, at least 4 times the Working Load Limit (WLL)
- Continuous cyclic testing of over 1500 cycles
- Chain end anchorage test, passing at least 2.5 times the WLL without any restriction of the brake or gears

Test on every hoist

- Proof loading at 1.5 times the rated capacity
- Light load testing at maximum of 2 % rated capacity



Product Code	Capacity (tonne)	Effort (kg)	Dimensions (mm)							Load Chain		Standard HOL (m)	Mass @ std HOL (kg)	Mass for extra metre HOL (kg)
			A	B	C	D	E	F1	F2	Diameter (mm)	No. of falls			
CB-0025	0.25	17	64	40	240	36	60	22	31	ø4.0	1	3	3.8	0.5
CB-0050	0.5	21	93	66	305	52	78	24	38	ø6.3	1	3	10.5	1.9
CB-0100	1.0	25	93	66	340	63	87	28	45	ø6.3	1	3	11.5	1.9
CB-0150	1.5	32	98	73	385	78	102	34	51	ø7.1	1	3	16.0	2.1
CB-0200	2.0	34	101	79	420	87	113	35	53	ø8.0	1	3	20.0	2.4
CB-020L	2.0	42	98	73	399	78	102	35	53	ø7.1	1	3	16.5	2.1
CB-0300	3.0	38	109	84	500	98	157	36	56	ø10.0	1	3	30.5	3.2
CB-030T	3.0	34	98	73	488	60	148	36	56	ø7.1	2	3	23.0	3.2
CB-0500	5.0	37	101	79	575	122	209	49	70	ø8.0	3	3	37.5	5.2
CB-0600	6.0	38	109	84	635	86	220	49	70	ø10.0	2	3	45.5	5.3
CB-0800	8.0	34	109	84	610	153	263	51	78	ø10.0	3	3	61.0	7.5
CB-1000	10.0	40	109	84	660	153	263	54	87	ø10.0	3	3	64.0	7.5
CB-1500	15.0	41	109	84	840	225	378	59	81	ø10.0	5	3	128.5	11.8
CB-2000	20.0	43	161	90	1050	148	360	81	110	ø10.0	6	3	178.5	14.2
CB-200T	20.0	43	161	161	1050	383	383	81	110	ø10.0	6	3	210.5	15.2
CB-3000	30.0	42	220	220	1200	388	388	91	135	ø10.0	10	3	307.0	23.8
CB-3500	35.0	40	240	240	1200	390	390	91	135	ø10.0	12	3	365.0	27.0

See page 8 for more hook information

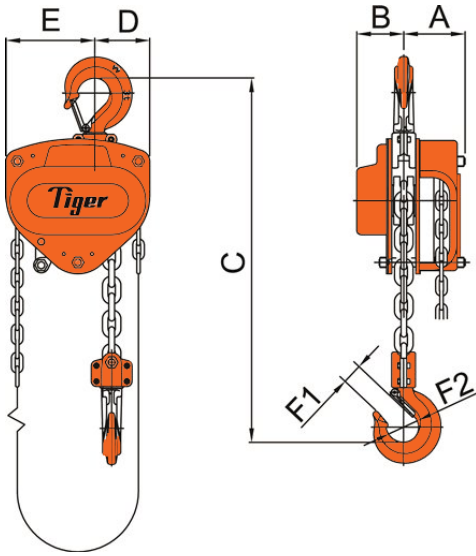

0.25t – 2.0t/3.0t single

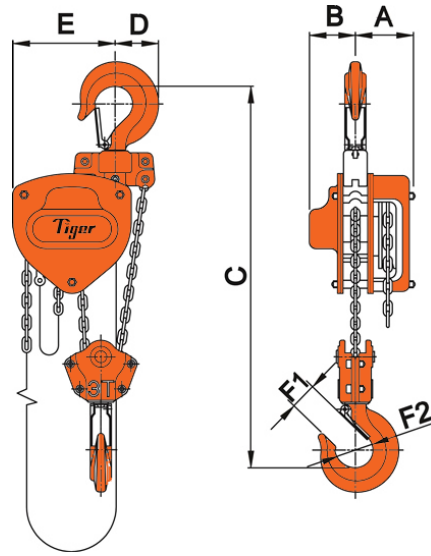

3.0t twin fall

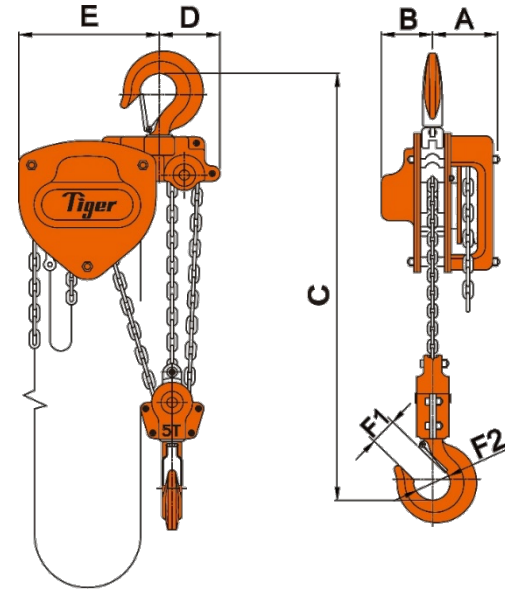

5.0t

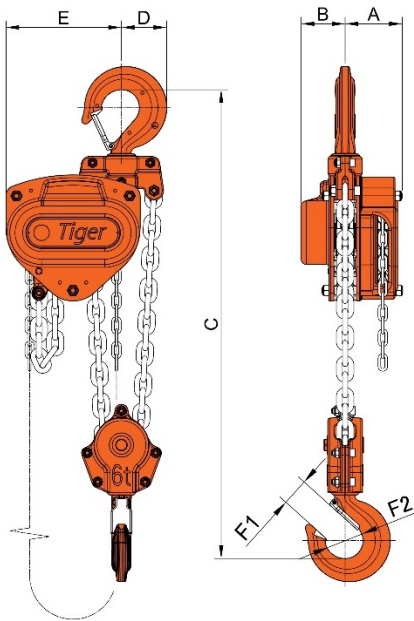

6.0t

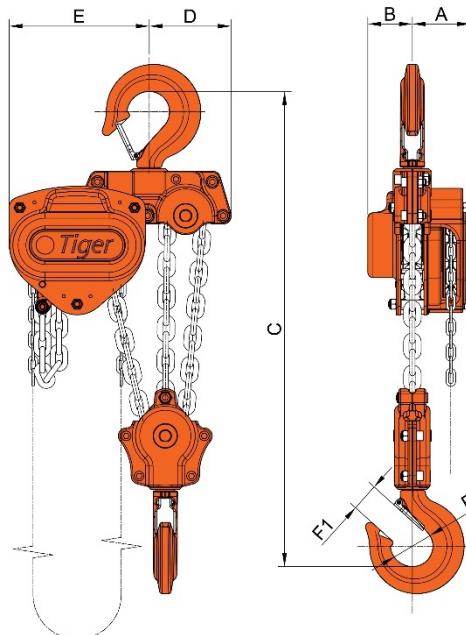

8.0t

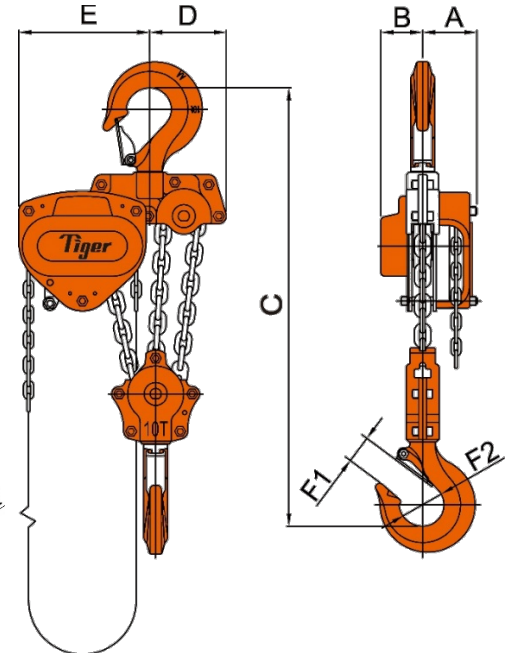

10.0t



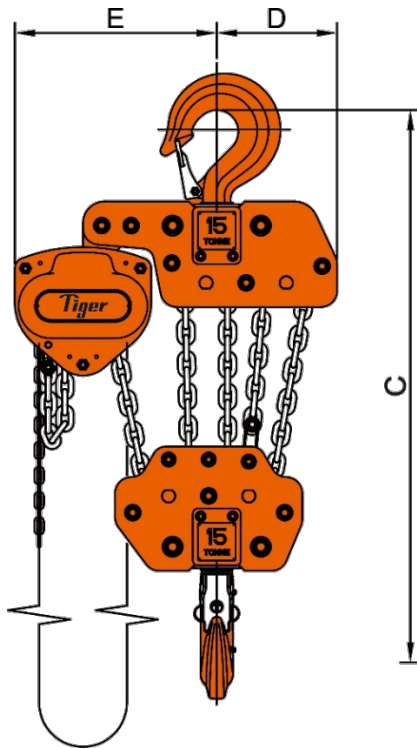

15.0t

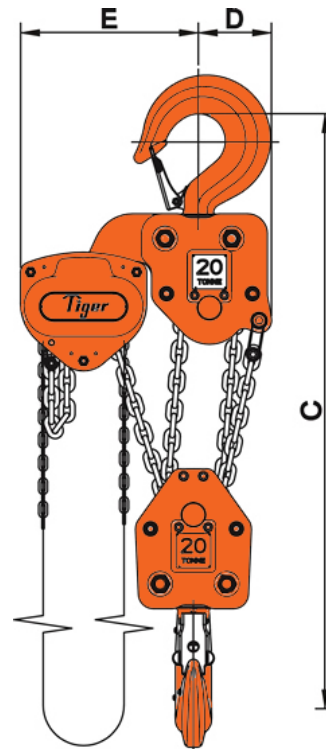
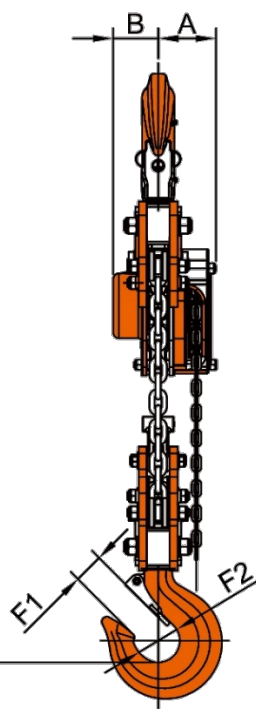

20.0t

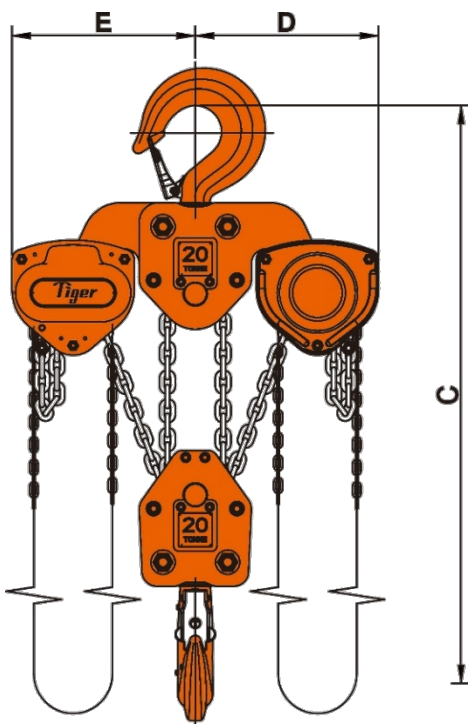
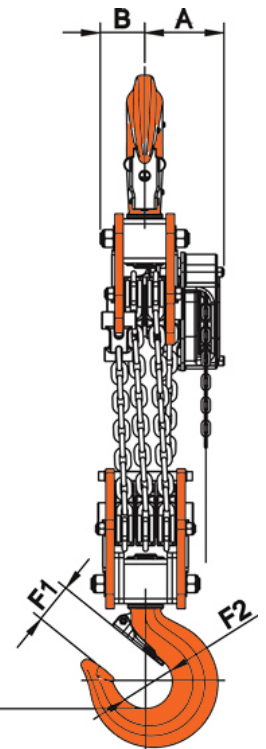

20.0t twin head

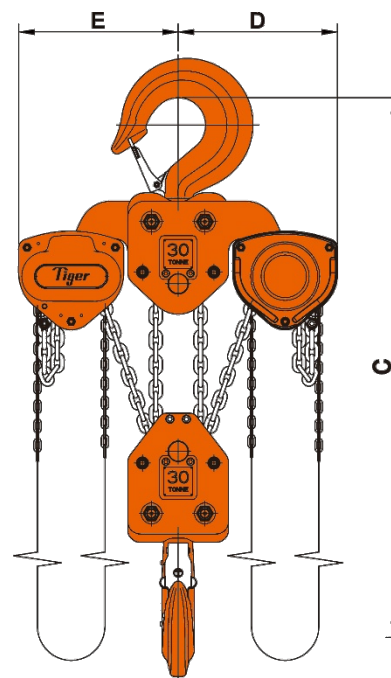
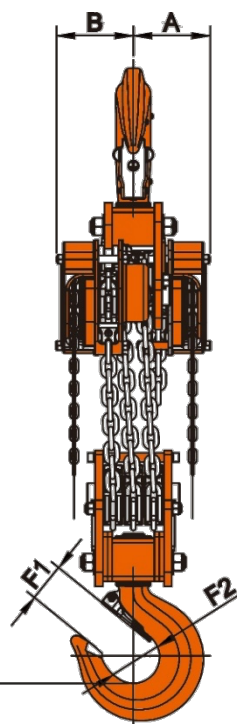

30.0t

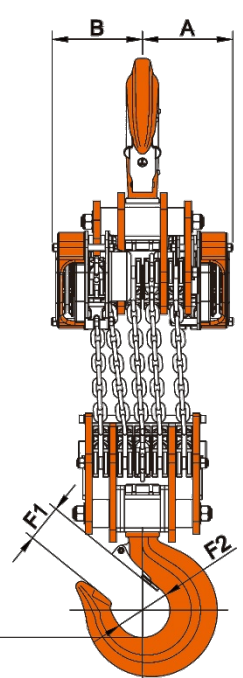

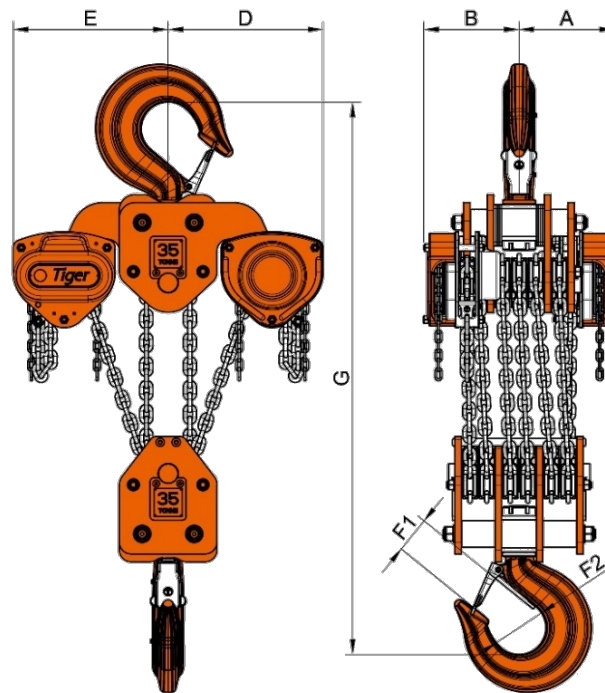

35.0t

### Hook Technical Data

Capacity (Tonnes)	Collar measurements (mm)		Hook thickness at point shown in diagram (mm)		Hook throat Opening (mm)	"EZ Check" measurement (mm)
	a	b	c	d	e	f
0.25	5	8	18	12	26	43
0.5	8	13.5	19	15	29	47
1.0	8	13.5	23	17	34	52
1.5	10	15.5	26	21	39	59
2.0	9	17.5	30	22	42	64
3.0	12.5	20	37	32	42	76
5.0/6.0	19	30	43	36	57	86
8.0	20.7	33	50	43	60	110
10.0	20	33	52	48	70	121
15.0	-	36	67	60	65	130
20.0	-	48	77	72	90	162
30.0/35.0	-	56	94	78	101	177

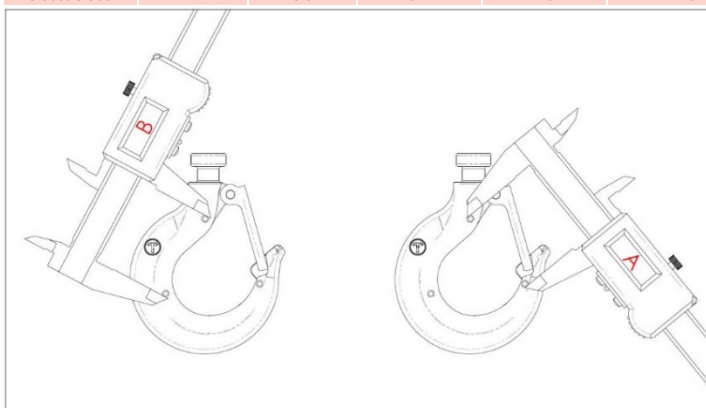
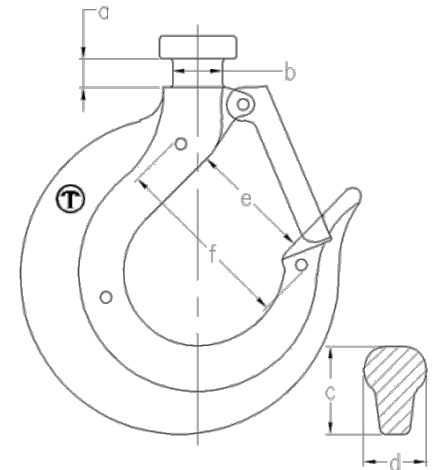

PROCB chain blocks are fitted with the patented Tiger "EZ check" 3 point marking system. With this system a quick check that the A and B measurements are the same (as shown in the diagram below) will indicate if the hooks have stretched. If  $A \leq B$  the hook is fine; If  $A > B$  the hook needs to be replaced.

Due to our policy of continual product development, dimensions, weights and specifications may change without prior notice. Please check with your Tiger sales team when ordering.

Bespoke designs available on request – contact [info@tigerlifting.com](mailto:info@tigerlifting.com) for more information.