

Tiger Industrial Range

Industrial range of chain blocks, lever hoists, trolleys and beam clamps



Universal wheels



Main Features

- Plain/push and geared trolleys - 500kg – 5.0t
- Beam Clamps - 1.0t to 10.0t
- Chain Blocks - 500kg – 5.0t
- Lever Hoists - 750kg – 6.0t
- Rugged steel body construction yet lightweight and portable
- Meets or exceeds all international standards
- Trolley wheels are powder coated universal wheels which suit both tapered and flat flange beams

Hoists

- Drop forged & heat-treated alloy hooks
- Safe reliable twin pawl mechanical brake
- High quality alloy calibrated load chain
- Proof tested to 1.5 times rated capacity
- Guaranteed light load protection
- All Tiger lever hoist handles contain rubber which is free from phthalates

Additional Lever Hoist Features

- 360-degree handle rotation
- Heavy duty chain end-stop
- Short stroke and low lever pulling effort
- Easy single-hand “freewheeling” operation

Our innovation, your safety

Certification:

Each unit comes fully certified with a test certificate or an EC Declaration of Conformity stating compliance with the essential health and safety requirements of the Machinery Directive 2006/42/EC.

Lever Hoists

Product Code	Capacity (tonne)	Effort (kg)	Dimensions (mm)							Load Chain		Standard HOL (m)	Mass @ std HOL (kg)	Mass for extra metre HOL (kg)
			A	B	C	D	E	F1	F2	Diameter (mm)	No. of falls			
TRL-0075	0.75	23	128	240	275	158	99	24	38	∅6.3	1	1.5	7.5	0.9
TRL-0100	1.0	29	128	236	295	158	99	28	45	∅6.3	1	1.5	7.5	0.9
TRL-0150	1.5	26	154	360	320	172	104	34	51	∅7.1	1	1.5	10.0	1.1
TRL-0200	2.0	35	154	360	367	172	104	35	53	∅7.1	1	1.5	10.5	1.1
TRL-0300	3.0	38	182	360	400	195	108	36	56	∅10.0	1	1.5	18.0	2.2
TRL-0600	6.0	40	242	360	570	195	108	49	70	∅10.0	2	1.5	29.5	4.3

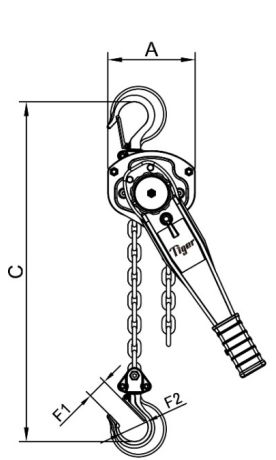

0.75t-3.0t

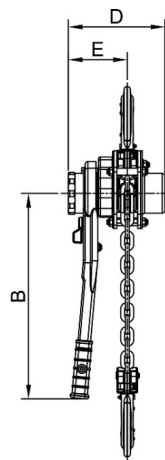

6.0t

Chain Blocks

Product Code	Capacity (tonne)	Effort (kg)	Dimensions (mm)							Load Chain		Standard HOL (m)	Mass @ std HOL (kg)	Mass for extra metre HOL (kg)
			A	B	C	D	E	F1	F2	Diameter (mm)	No. of falls			
TRC-0050	0.5	21	93	66	305	52	78	24	38	∅6.3	1	3	10.5	1.9
TRC-0100	1.0	25	93	66	340	63	87	28	45	∅6.3	1	3	11.5	1.9
TRC-0150	1.5	32	98	73	385	78	102	34	51	∅7.1	1	3	16.0	2.1
TRC-0200	2.0	34	101	79	420	87	113	35	53	∅8.0	1	3	20.0	2.4
TRC-030T	3.0	34	98	73	488	60	148	36	56	∅7.1	2	3	23.0	3.2
TRC-0500	5.0	37	101	79	575	122	209	49	70	∅8.0	3	3	37.5	5.2

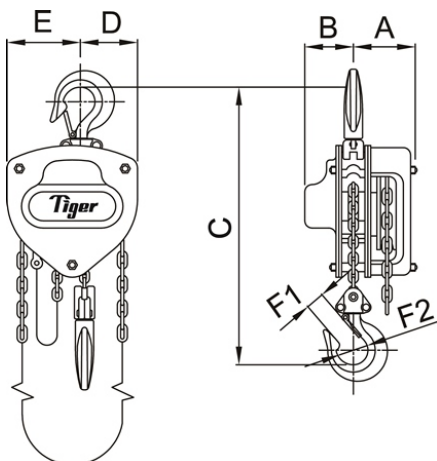

0.5t – 2.0t

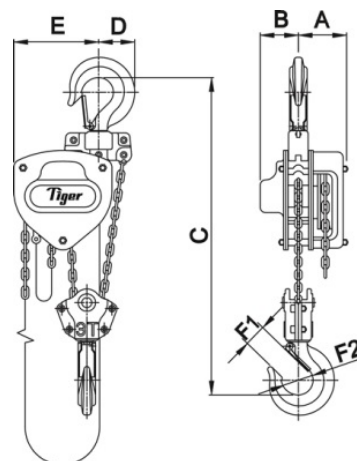

3.0t twin fall

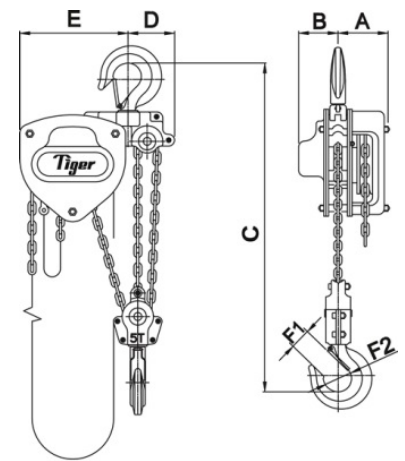

5.0t

Screw Push Trolley

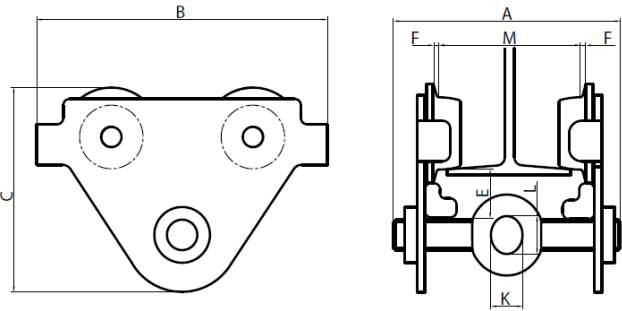

Product Code	Capacity (tonne)	Beam Range M	Dimensions (mm)								Min. curve ratio (m)	Net Weight (kg)
			A	B	C	E	F	K	L			
SPT-0050	0.5	50-220	300	210	190	33	3	25	30	0.9	7.0	
SPT-0100	1.0	64-220	300	260	211	31	3	30	35	1.0	10.0	
SPT-0200	2.0	88-220	310	310	236	32	3	40	47	1.1	15.5	
SPT-0300	3.0	102-220	320	390	295	46	3	48	58	1.3	26.0	
SPT-0500	5.0	114-220	330	450	334	47	3	60	70	1.4	38.0	

Screw Geared Trolley

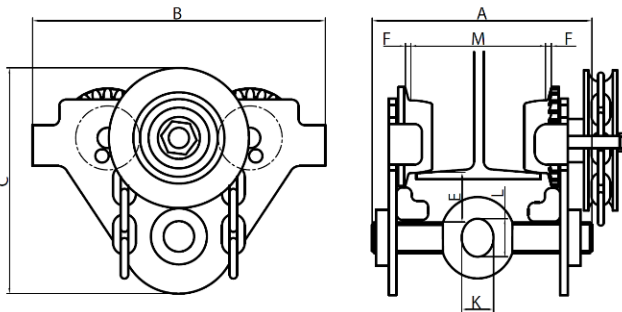

Product Code	Capacity (tonne)	Beam Range M	Dimensions (mm)								Min. curve ratio (m)	Net Weight (kg)
			A	B	C	E	F	K	L			
SGT-0050	0.5	50-220	300	210	190	33	3	25	30	0.9	9.0	
SGT-0100	1.0	64-220	300	260	211	31	3	30	35	1.0	13.0	
SGT-0200	2.0	88-220	310	310	236	32	3	40	47	1.1	20.5	
SGT-0300	3.0	102-220	320	390	295	46	3	48	58	1.3	30.0	
SGT-0500	5.0	114-220	330	450	334	47	3	60	70	1.4	45.0	

Beam Clamp

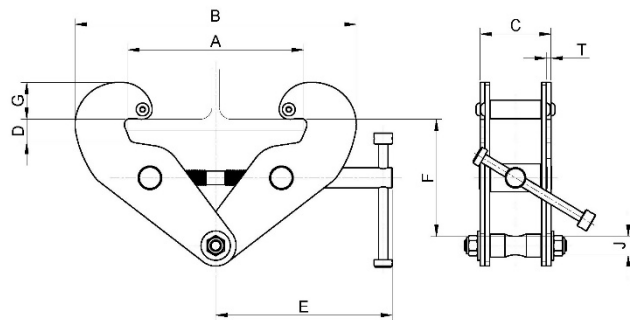

Product Code	Capacity (tonne)	Dimensions (mm)									Net Weight (kg)
		A	B	C	D	E	F	G	J		
BC-0100	1.0	75-210	182-328	77	26	190	144-117	52-38	20	4.0	
BC-0200	2.0	75-210	182-328	85	26	190	144-117	52-38	20	4.5	
BC-0300	3.0	75-305	214-460	107	35	240	224-179	58-40	22	8.0	
BC-0500	5.0	75-305	214-460	121	35	240	224-175	58-40	28	10.0	
BC-1000	10.0	120-350	295-510	182	36	300	222-171	71-54	43	24.5	

Due to our policy of continual product development, dimensions, weights and specifications may change without prior notice. Please check with your Tiger sales team when ordering.

Bespoke designs available on request – contact info@tigerlifting.com for more information.