

Tiger Electric Ceiling Mounted Winch SF-5000E

The Tiger 5000 Electric Ceiling Winch has a 2270kg rated capacity on the first layer of cable or strap around the drum. It comes pre-wired with a motor and controller for easy installation. The winch is designed to pull 2 lines in opposite directions simultaneously. Never pull in just one direction with this winch. The brake motor allows for a sure and safe stop. No assembly required, to install the winch simply plug it in, and press up or down.



- 5000lb/2270kg capacity based on the first layer of cable or strap around the drum. Additional layers reduce capacity.
- New manual override option
- ¾ HP motor
- 1670 RPM motor with a 6/1 reduction for a net motor RPM of 278 and drum RPM of 3.09
- Lift speed approximately 610mm per minute at the drum
- Voltage: 110-115
- Amperage: 7 at full load
- Weight: 19kg
- Drum ID: 51mm – OD 140mm
- 2743mm power cord & 2743mm controller cord
- Holds approximately 19507 mm of 4.8mm cable
- Recommended 2:1 double-back for loads exceeding 1134kg
- Power Supply: 110V 1-Phase (Standard) / 220V 1-Phase (Optional/Upon request)

Certification:

Each unit comes fully certified with a test certificate or an EC Declaration of Conformity stating compliance with the essential health and safety requirements of the Machinery Directive 2006/42/EC.

Technical Data

Product Code	Rated Capacity (lbs/kg)	Hand Force (kg)	Gear Ratio	Hub Diameter (mm)	Handle Length (mm)	Unit Weight (with handle) (kg)	Unit Weight (with loop) (kg)	Cable Diameter (mm/inch)	Cable Storage Cap. (m)
SF-5000E	5000/2270	-	90.24:1	ø65	-	-	23.14	ø6.4/ø1/4	11*2

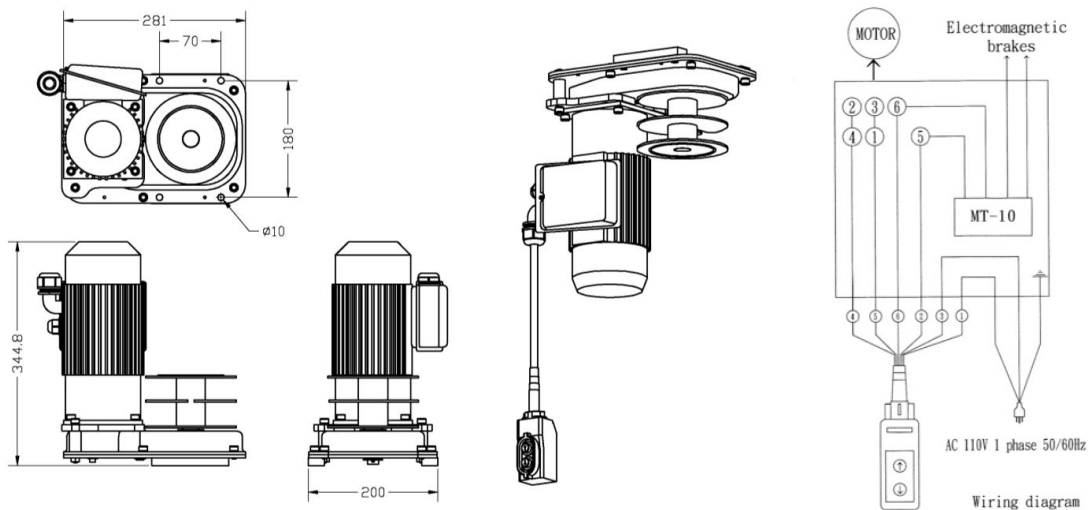

Due to our policy of continual product development, dimensions, weights and specifications may change without prior notice. Please check with your Tiger sales team when ordering.

Bespoke designs available on request – contact info@tigerlifting.com for more information.

Our innovation, your safety