

Tiger Safety Screw Cam Clamp Model No. CSS



Main Features

- Range – 500kg to 6.3t
- Spherical universal designed screw cam provides an extra powerful clamping force on a workpiece even when vibrations occur during operation.
- Cam holder and collar have phosphorescent (glow-in-the dark) paint for easy recognition of adequate torque tightening.
- No tools required – integrated adjusting screw spindle
- 4:1 factor of safety

These units meet the requirements within BS EN 13155:2003.

The Tiger CSS safety screw cam clamp with Double Eye Anchor Points & Safety Torque Feature is suitable for many applications. This screw cam clamp has many uses, such as lifting, lateral pulling and turning over materials. Adequacy of tightening can be confirmed by the visual torque safety feature. The main body of the clamp is special alloy steel, mold forged and processed with optimal heat treatment making it extremely strong and durable. The disc spring built into the body of the clamp prevents loosening of the screws. The spherical based cam tilts in proportion to the lifting load so the contact surface becomes larger and clamps more firmly. There are two shackle holes - one opposite the screw and the other at a right angle direction, so you can choose the most suitable hole for your application.

Certification:

Each unit comes fully certified with a test certificate or an EC Declaration of Conformity stating compliance with the essential health and safety requirements of the Machinery Directive 2006/42/EC.



Untorqued



Torqued – ready for use



Luminescent indicators - cam holder and collar have phosphorescent (glow-in-the dark) paint for easy recognition of adequate torque tightening.

Examples of use:

Our innovation, your safety.

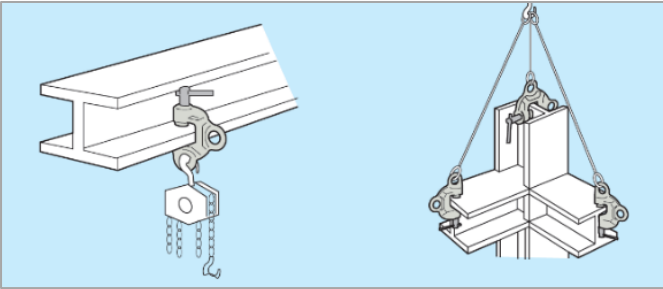

Always lift workpieces at two or more points for safety.

Recommendation:

We advise that structural calculations are carried out on all beams and supporting steel work by qualified engineering departments to ensure safe operation.

Technical Data

Product Code	Capacity (tonne)	JO (Jaw Opening)	Dimensions (mm)										Net Weight (kg)
			L	L2	H	H1	H2	D1	D2	T1	T2	S	
CSS-0050	0.5	0-25	158	89	121	72	30	27	27	46	13	17	1.9
CSS-0100	1.0	0-40	208	121	161	94	45	32	32	54	14	21	3.6
CSS-0200	2.0	0-40	227	121	177	105	45	36	32	60	18	21	4.8
CSS-0320	3.2	0-40	252	136	196	119	50	45	35	64	20	21	7.0
CSS-0630	6.3	0-50	291	151	225	132	55	50	41	90	43	21	17.0

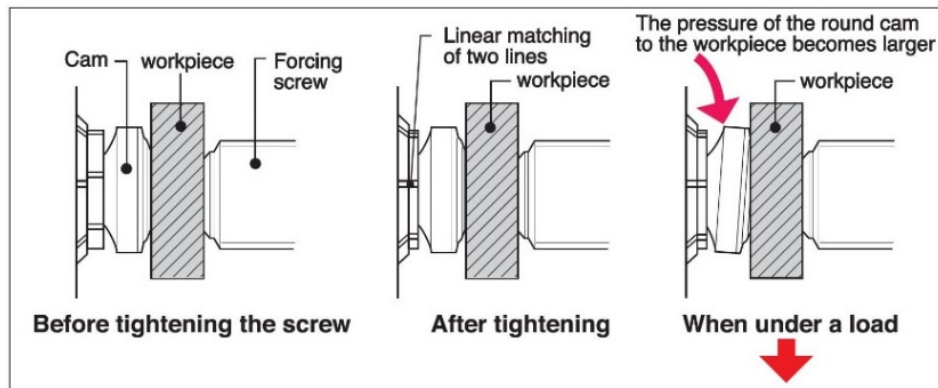
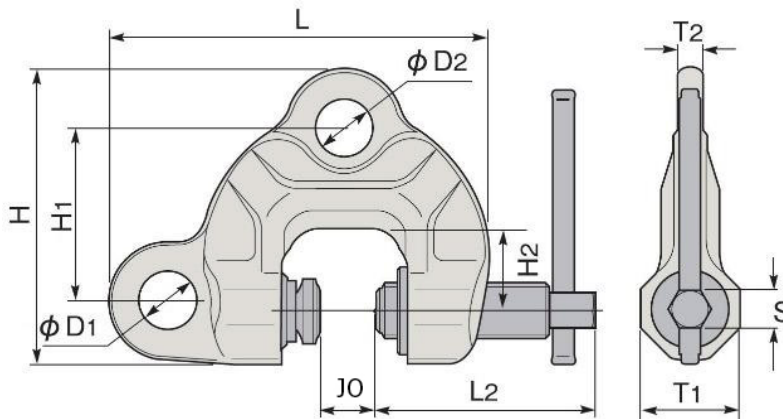

Due to our policy of continual product development, dimensions, weights and specifications may change without prior notice. Please check with your Tiger sales team when ordering.

Bespoke designs available on request – contact info@tigerlifting.com for more information