

Tiger Beam Clamp with Shackle Model No. BCS



With optional locking device



Main Features

- Range from 1.0t to 10.0t
- Quick and versatile rigging point for hoisting equipment
- Shackle suspension point
- Highly flexible – for lifting, pulling or as an anchor point
- Multidirectional adjusting screw spindle for easy attachment and safe and secure grip
- Wide Beam flange adjustment range
- Operating temperature -40°C to +80°C (temperature range of -60°C to +80°C available as an option)
- Factor of safety: 5:1 for straight pulling and lifting, 4:1 at angles up to 45° (applying the appropriate reduction in WLL)
- Optional locking device

These units meet and exceed all the requirements within BS EN 13155:2003+A2:2009 and AS4991.

Certification:

Each unit comes fully certified with a test certificate or an EC Declaration of Conformity stating compliance with the essential health and safety requirements of the Machinery Directive 2006/42/EC.

We hold complete technical files for our products to provide full back-up and reassurance on our products' performance and to ensure that advice for our equipment is readily available.

Reduction in working load limits when side loads applied:

Angle from vertical	0°	0° - 15°	15° - 30°	30° - 45°
Reduction Factor	Nil	17 %	34 %	50 %
Product Code	WLL (kg)			
BCS-0100	1,000	830	660	500
BCS-0200	2,000	1,660	1,320	1,000
BCS-0300	3,000	2,500	2,000	1,500
BCS-0500	5,000	4,100	3,300	2,500
BCS-1000	10,000	8,300	6,600	5,000

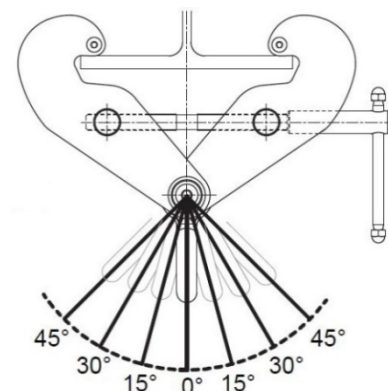

The above working load limits and derations have been established for Tiger BCS model clamps and apply only for overhead beam attachments. They DO NOT apply when used for lifting beams. Our Tiger BCU clamp has been specifically designed for this purpose. The above tables apply only to the Tiger BCS model and we advise that structural calculations are carried out on all beams and supporting steel work by qualified engineering departments to ensure safe operation.

Our innovation, your safety.

Technical Data

Product Code	Capacity (tonne)	Dimensions (mm)												Net Weight (kg)
		A	B	C	D	E	F	G	H	J	K	L	T	
BCS-0100	1.0	75-210	182-328	77	24	195	250-225	52-38	16	21	81	83	5	4.5
BCS-0200	2.0	75-210	182-328	85	24	195	260-236	52-38	18	21	89	94	6	5.5
BCS-0300	3.0	75-305	214-460	107	25	250	357-311	58-40	22	27	112	105	8	9.5
BCS-0500	5.0	75-305	214-460	121	25	250	363-315	58-40	27	27	125	111	10	11.0
BCS-1000	10.0	120-350	295-510	181	30	300	381-330	71-54	32	37	83	120	16	26.5

D=maximum beam flange thickness

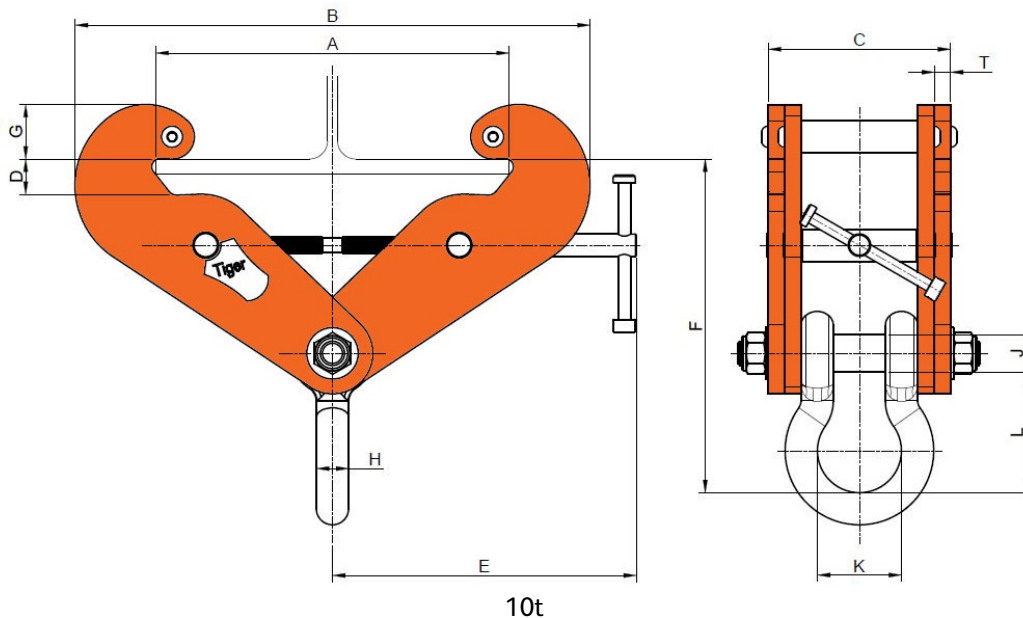
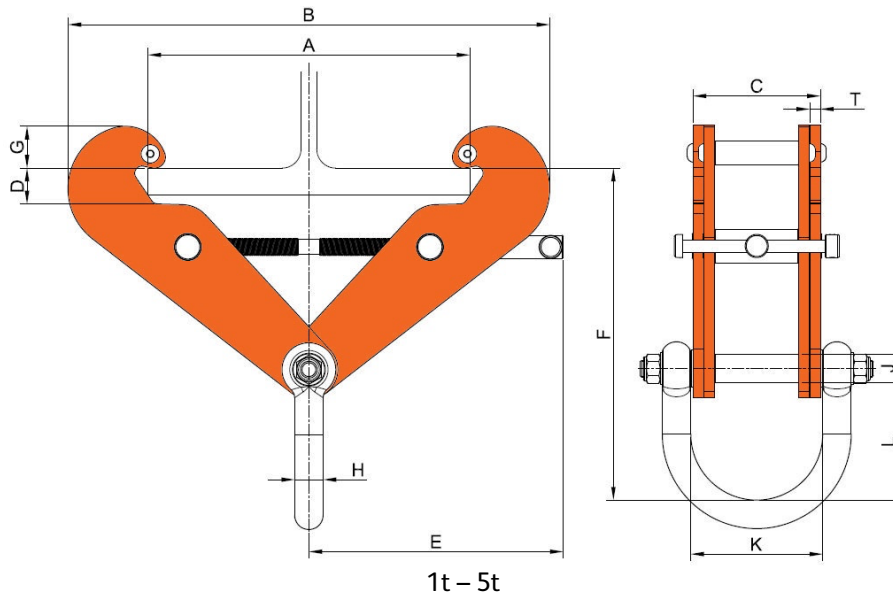

Due to our policy of continual product development, dimensions, weights and specifications may change without prior notice. Please check with your Tiger sales team when ordering.

Bespoke designs available on request – contact info@tigerlifting.com for more information.