

## Tiger Air Winches Series: WAR-I



### Main Features

- Range – 0.5, 1, 2 & 3 tonne
- Reliable, fast, efficient and quiet
- Compact design
- Extended drum versions available for increased rope capacity
- Easy to mount
- Greater than 5:1 factor of safety
- Available with the following controls - toggle or pendant



Tiger WAR-I series air winches are designed specifically for mining, construction, marine and general engineering applications. The compact design of the winches allows them to be installed quickly where required in any orientation. They comply with the requirements of ASME B30.7. The manufacturing facility producing the winches is ISO9001 certified.

### Load Limiter

All the WAR-I Series winches are fitted with an integral load limiter which automatically prevents overloading of the winch. Load limiter is 100 % repeatable at all working pressures and does not wear or generate damaging heat. The load limiter is set to activate at 175 % of WLL on the first layer, this enables the winch to lift the working load on the top working layer. The top working layer is considered to be full drum (max. storage capacity) less one layer.

### Emergency Stop

Winches can be supplied with an emergency stop device as an option. This shuts off the main air supply to the winch when activated.

### Precise Control

Lever control and pilot pendant control offer variable speed control. Accurate and precise positioning of loads is standard for all models.

### Fail Safe Disc Brake

Non-asbestos self-adjusting disc brake is applied automatically when the air supply to the winch is shut off. The brake is self-adjusting for the life of the brake and is capable of holding in excess of 125 % of the working load limit.

### Integral Silencer

The exhaust air silencer is built into the winch frame and limits the noise level to 80dB(A).

### Vane Motor

Assisted vane lifting ensures maximum starting torque when starting under load.

### Sealed Gearbox

The sealed planetary gearbox ensures that the most stringent duty cycles can be met. The gears are heat treated and mounted on high strength, low friction bearings.

### Ease of Maintenance

The modular design of the winch allows easy access to internal components such as the motor, gearbox, brake, load limiter and drum assembly. Common parts are used throughout the range.

### Technical Data

Technical Specifications at 6 bar	AW-005	AW-010	AW-020	AW-030
Half Drum Line Pull (kg)	500	1000	2000	3000
Rope Speed at Rated Load (m/min)	28.10	13.90	6.70	4.60
Full Drum No Load Speed (m/min)	60.30	28.20	18.50	9.00
Air Consumption (m <sup>3</sup> /min)	4.0	4.0	4.0	4.0
Air Connection	G $\frac{3}{4}$	G $\frac{3}{4}$	G $\frac{3}{4}$	G $\frac{3}{4}$
Supply Hose (Inside Ø) (mm)	25	25	25	25
Sound Level (dB(A))	80	80	80	80
Recommended Rope Size (mm)	13.0	13.0	15.0	18.0
Rope Storage Length (m) – Standard Drum	80	80	59	52
Rope Storage Length (m) – Extended Drum	165	165	119	106
Weight without Wire Rope (kg) - Std	104	104	104	104

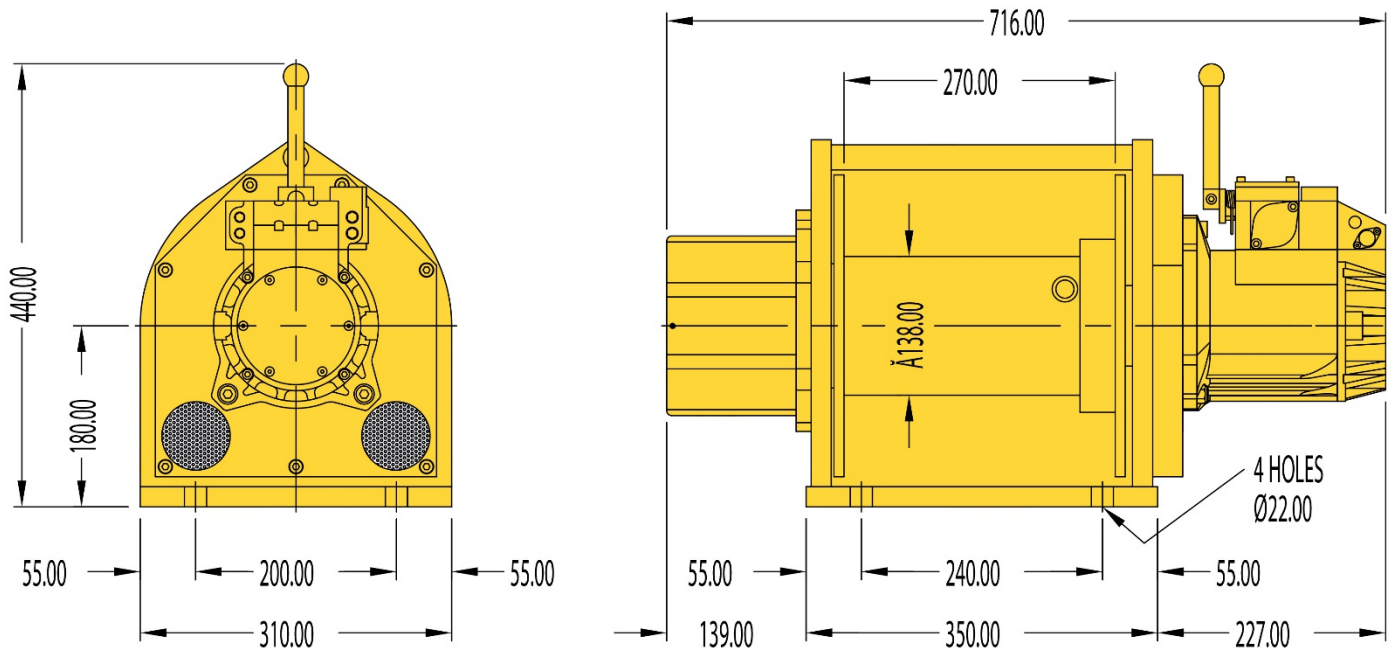

Due to our policy of continual product development, dimensions, weights and specifications may change without prior notice. Please check with your Tiger sales team when ordering.

Bespoke designs available on request – contact [info@tigerlifting.com](mailto:info@tigerlifting.com) for more information.