

## Tiger Air Trolleys



### Main Features

- 1, 3, 6 and 10 tonne capacity units
- Low headroom, compact and versatile
- Available in plain, geared and motorized versions
- Greater than 5:1 factor of safety
- Anti-fall, anti-derailment and anti-tilt features as standard

T series trolleys are designed specifically for mining, industrial and general engineering applications. The trolleys are available in plain, geared and motorized versions and can be supplied with rigid or hook on adaptors. They have a minimum factor of safety of 5 at the maximum rated load and are therefore suitable for use with both manual and powered hoists. The trolleys comply with the requirements of SANS 1824, EN13157 and EN14492-2. The manufacturing facility producing the trolleys is ISO9001 certified.

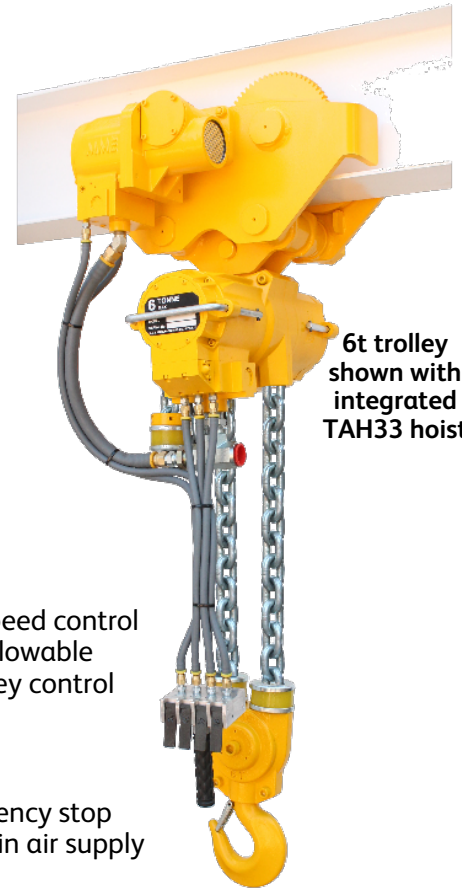

6t trolley shown with integrated TAH33 hoist



3t trolley shown with TAH33 hoist

### Precise Control

Infinitely variable control offers precise speed control from creep to full speed. The maximum allowable traverse speed can also be set on the trolley control valve.

### Emergency Stop

All trolleys can be supplied with an emergency stop device as an option. This shuts off the main air supply to the trolley when activated.

### Low Headroom

Compact design reduces headroom. Rigid adaptor further reduces headroom.

### Versatility

Trolley fits a wide variety of beam widths. They can accommodate both parallel and tapered flange beams. Hook on adaptor allows any hoist up to trolley capacity to be attached.

### Vane Motor

Assisted vane lifting ensures maximum starting torque when starting under load. Built in silencer limits noise level to 76dB(A).

### Automatic Stopping

Motorized traverse drive stops automatically due to the worm drive when the air supply is shut off. Additional traverse brake is optional.

### Small Turn Radius

Trolleys can negotiate small turn radii in the support beam.

## Ease of Maintenance

The modular design of the trolley allows easy access to internal components such as the motor & gearbox. Common parts are used throughout the range.

## Technical Data

Product Code	Capacity (tonne)	For use with Air Hoist Model	Track width range (mm)		Max flange thickness (mm) †	Min. curve radius (mm)	Net Weight (kg)	Max. Traverse Speed (m/min) @ 6 bar
			Range 1	Range 2				
TA1000	1.0	AH-010	73-166	73-203	20	900	30.5	22.0*
TG1000	1.0	AH-010	73-166	73-203	20	900	21.2	-
TP1000	1.0	AH-010	73-166	73-203	20	900	18.2	-
TA2000	2.0	AH-020 or AH-021	89-184	89-230	25	950	44.0	28.0*
TA3000	3.0	AH-030	89-184	89-230	25	950	44.0	28.0*
TG3000	3.0	AH-030	89-184	89-230	25	950	34.7	-
TP3000	3.0	AH-030	89-184	89-230	25	950	31.7	-
TA6000	6.0	AH-050 or AH-060	128-200	128-305	25	1600	80.0	27.0*
TG6000	6.0	AH-050 or AH-060	128-200	128-305	25	1600	72.0	-
TP6000	6.0	AH-050 or AH-060	128-200	128-305	25	1600	69.0	-
TA10200	10.0	AH-102 or AH-103	150-320	N/A	30	2800	153.0	23.0*
TG10200	10.0	AH-102 or AH-103	150-320	N/A	30	2800	145.0	-
TP10200	10.0	AH-102 or AH-103	150-320	N/A	30	2800	142.0	-

\* Variable traverse speed is standard on the motorized TA series trolley.

† Other flange thicknesses available on request – ask us for details.

1t capacity units:

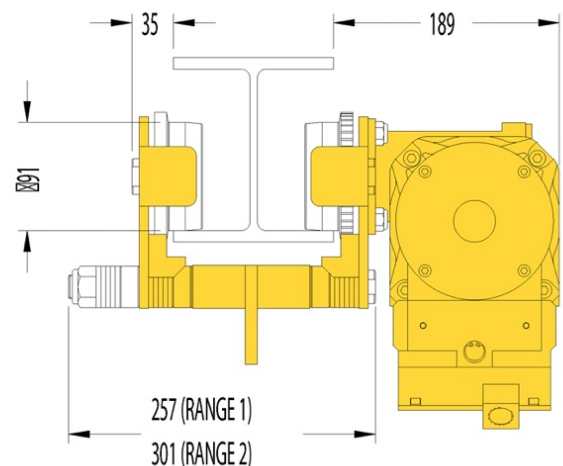
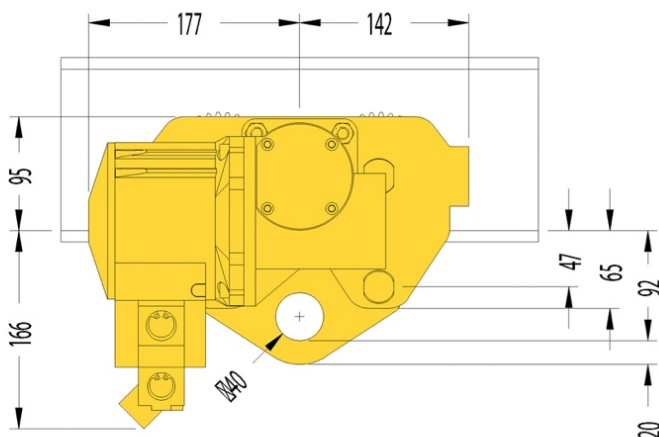
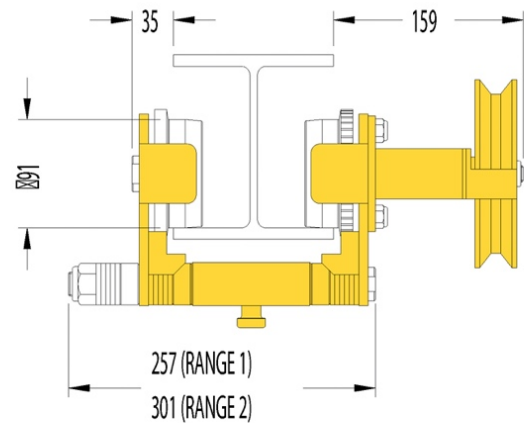
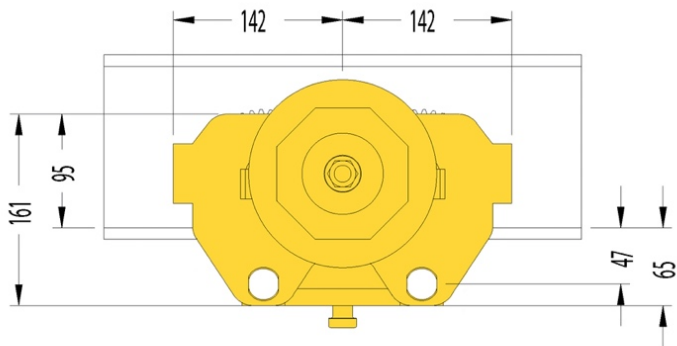

3t capacity unit:

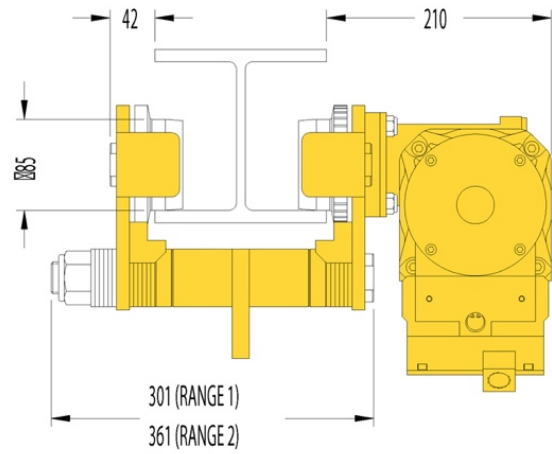
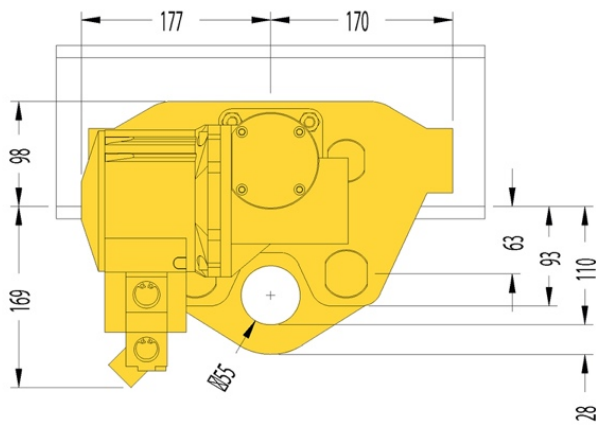
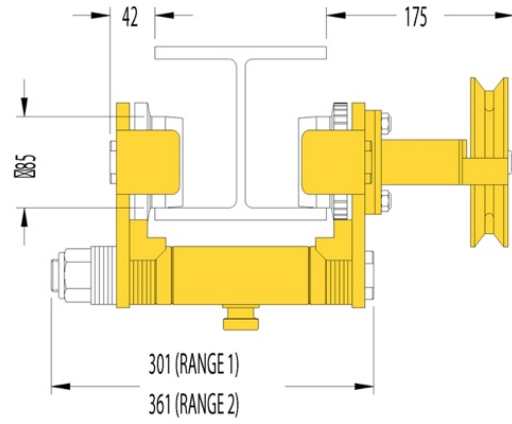
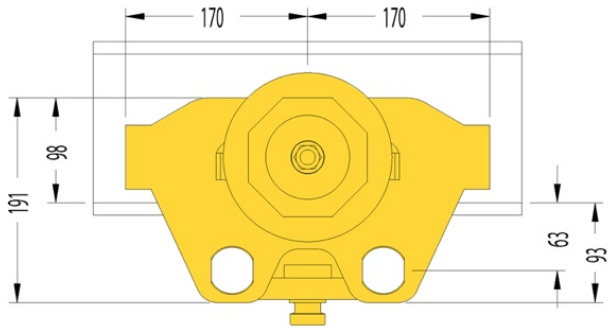

6t capacity unit:

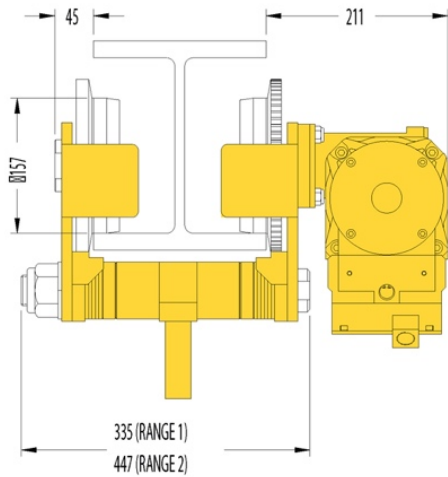
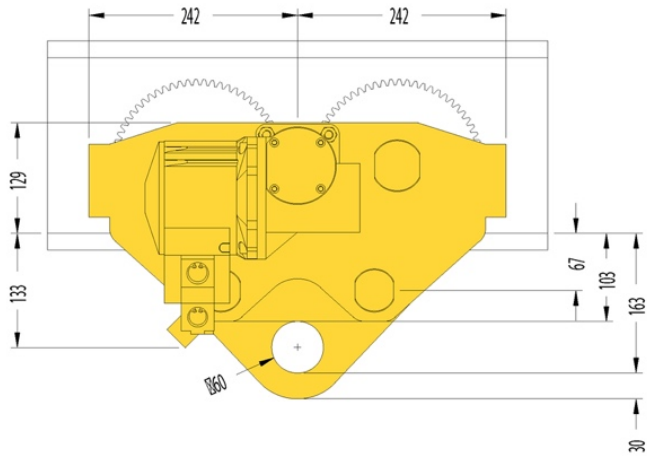
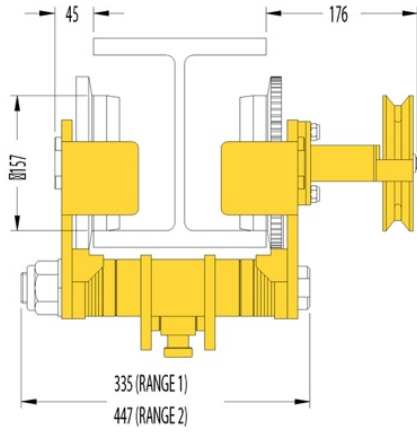
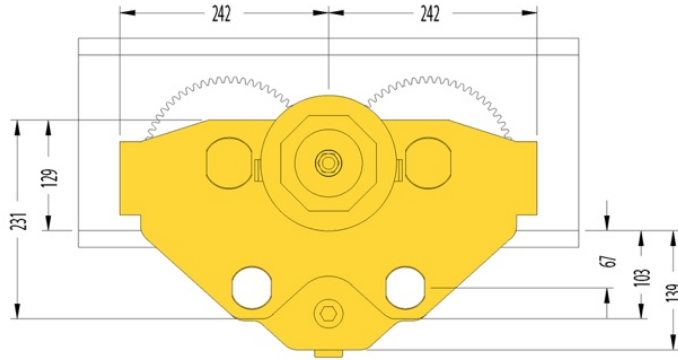

10t capacity unit:

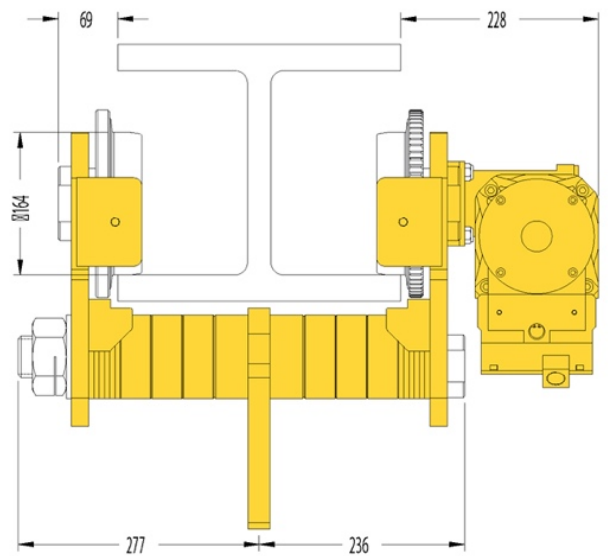
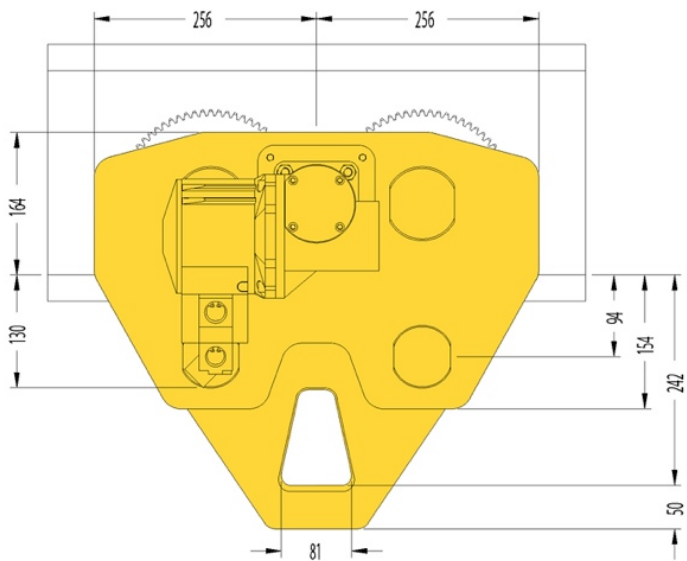
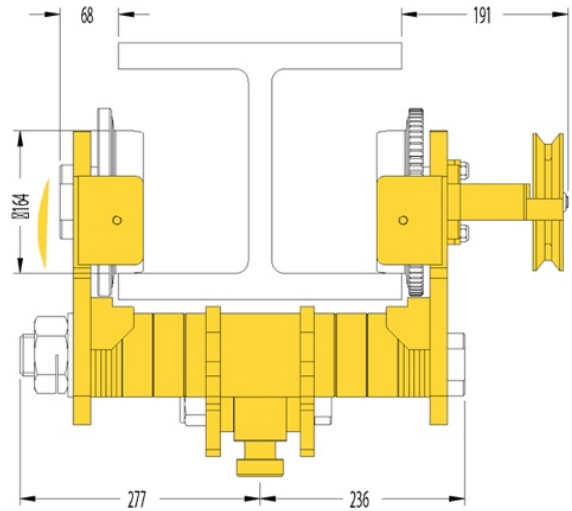
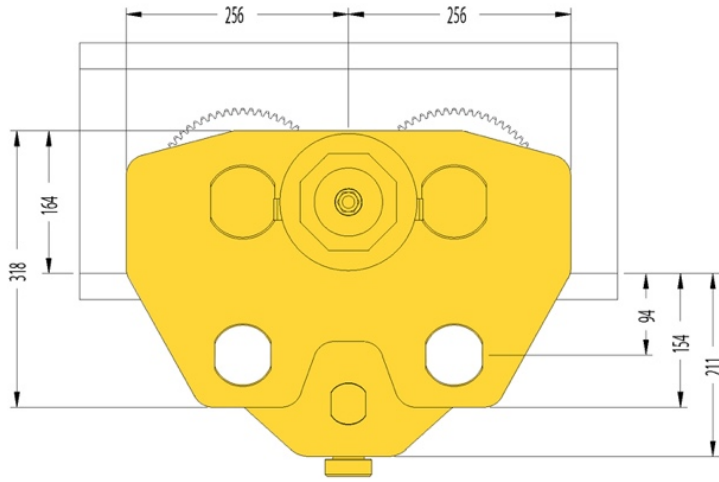

How to Order: Example: TA6000HPE2

Series	Type	Max Load (kg)	Attachment	Control	Pendant Type	Control Length (m)
T	A	6000	H	P	E	2
	A = Motorized G = Geared P = Plain	1000 3000 6000	H = Hook On R = Rigid	P = Pendant T = Toggle	E = 3 Hose F = 5 Hose	

Due to our policy of continual product development, dimensions, weights and specifications may change without prior notice. Please check with your Tiger sales team when ordering.

Bespoke designs available on request – contact [info@tigerlifting.com](mailto:info@tigerlifting.com) for more information.