

Bolt On Tie Down Model No. 8-058

Main Features

- Pivots through 180° and allows side load lifting
- Manufactured from forged alloy steel, quenched and tempered
- Manufactured and tested in accordance with EN1677-1
- Load rated parts are 100 % magnaflux crack detected
- Individual forged parts are traceable to Test Certification
- Supplied without bolts
- Proof tested to 2.5 times the WLL
- Fatigue rated to 1.5 times the WLL
- All YOKE Lifting points meet or exceed all the requirements of ASME B30.26



Certification:

Each unit comes fully certified with a test certificate or an EC Declaration of Conformity stating compliance with the essential health and safety requirements of the Machinery Directive 2006/42/EC, the Supply of Machinery (Safety) Regulations 2008 and Section 6 of the Health and Safety at Work Etc Act 1974.

Manufactured and tested in accordance with EN1677-1. All YOKE Lifting points meet or exceed all the requirements of ASME B30.26.

Technical Data

Product Code	Capacity (tonne)	Dimensions (mm)									Net Weight (kg)
		A	B	D	F	H	K	L	N	R	
8-058-1T	1.0	50	72	14	27	55	98	139	14	24	0.7
8-058-3T	3.0	58	84	17	33	50	114	144	18	29	1.1
8-058-5T	5.0	64	116	22	43	74	160	203	23	33	2.5

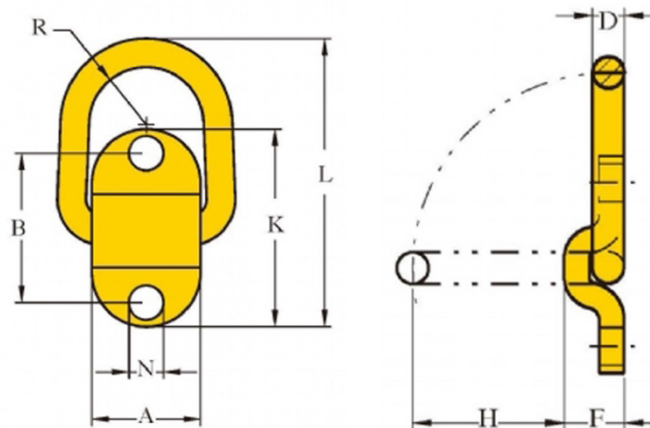

Due to our policy of continual product development, dimensions, weights and specifications may change without prior notice. Please check with your Tiger sales team when ordering.