

Tiger Fixed Jaw Heavy Duty Beam Clamp with Shackle Model No. BCF



15t unit with locking device



3t low headroom unit



10t unit



Available with beam protectors

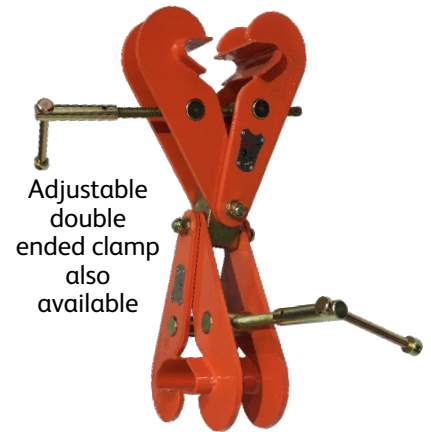

Adjustable double ended clamp also available

Main Features

- Range from 1.0t to 30.0t
- *NEW 6.0t and 10.0t models available to suit extra wide flange beams
- Quick and versatile rigging point for hoisting equipment
- Shackle suspension point
- Suitable for pulling and lifting at angles across the beam
- Up to 90° side loading with no deration
- 15° cross loading with no deration
- Highly flexible – for lifting, pulling or as a semi-permanent anchor point
- Evenly distributed loads achieved through maximum jaw surface area
- Multidirectional adjusting screw spindle ensures a high clamping force to the various flange sizes within its capacity
- Beam width range 75mm to 457mm
- Operating temperature -40°C to +80°C (temperature range of -60°C to +80°C available as an option)
- Factor of safety: 5:1 for straight pulling and lifting, 4:1 at other angles stated above
- Optional locking device for 1t-10t (as standard on 15t-30t)

These units meet and exceed all the requirements within BS EN 13155:2003+A2:2009 and AS4991.

Certification:

Each unit comes fully certified with a test certificate or an EC Declaration of Conformity stating compliance with the essential health and safety requirements of the Machinery Directive 2006/42/EC.

We hold complete technical files for our products to provide full back-up and reassurance on our products' performance and to ensure that advice for our equipment is readily available.



Heavy duty fixings and markings

NO reduction in working load limits when side loads applied:

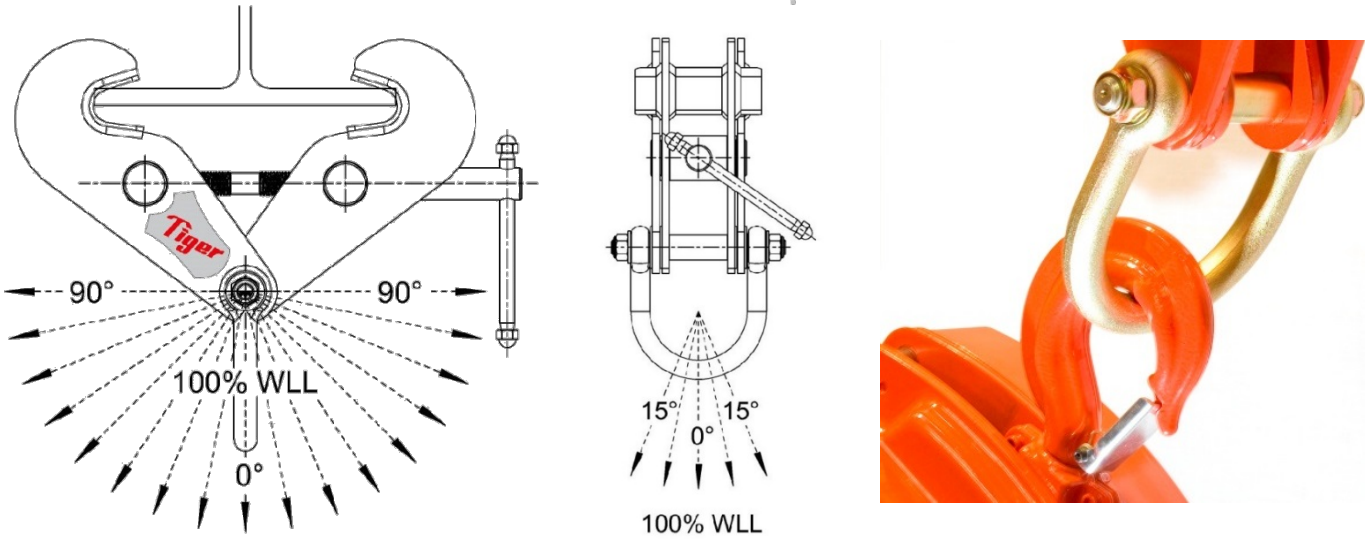

No deration up to 90° has been established for Tiger BCF model clamps and applies only for overhead beam attachments. It DOES NOT apply when used for lifting beams. Our Tiger BCU clamp has been specifically designed for this purpose.

We advise that structural calculations are carried out on all beams and supporting steel work by qualified engineering departments to ensure safe operation.

Technical Data

Product Code	Capacity (tonne)	Dimensions (mm)											Net Weight (kg)	
		A	B	C	D	E	F	H	J	K	L	M		T
BCF-0100	1.0	75-195	206-321	105	20	195	300-266	16	21	80	84		6	5.5
BCF-0200	2.0	75-195	206-321	105	20	195	311-276	18	21	88	95		8	6.5
BCF-0300	3.0	100-350	223-476	140	25	270	418-344	22	27	110	105		10	12.0
BCF-030S	3.0	75-190	216-325	140	20	195	310-271	22	27	110	105		10	9.5
BCF-0500	5.0	100-310	223-450	140	25	288	424-362	27	27	124	111		12	14.5
BCF-050S	5.0	75-190	216-325	140	20	195	315-276	27	27	124	111		12	11.0
BCF-0600	6.0	203-457	411-691	140	42	370	558-470	27	27	124	111		12	29.0
BCF-1000	10.0	120-350	282-527	210	30	316	460-382	32	37	83	120		16	28.0
BCF-100W	10.0	203-457	415-694	210	42	370	572-485	32	37	83	120		16	44.5
BCF-1500	15.0	203-457	463-742	250	36	416	644-558	38	44	99	146	400	20	76.0
BCF-2000	20.0	203-457	471-768	300	50	416	697-608	45	49	126	179	408	24	100.0
BCF-3000	30.0	203-457	483-800	385	63	416	742-648	50	57	138	197	416	38	152.0

T=beam clamp side plate thickness
D=maximum beam flange thickness

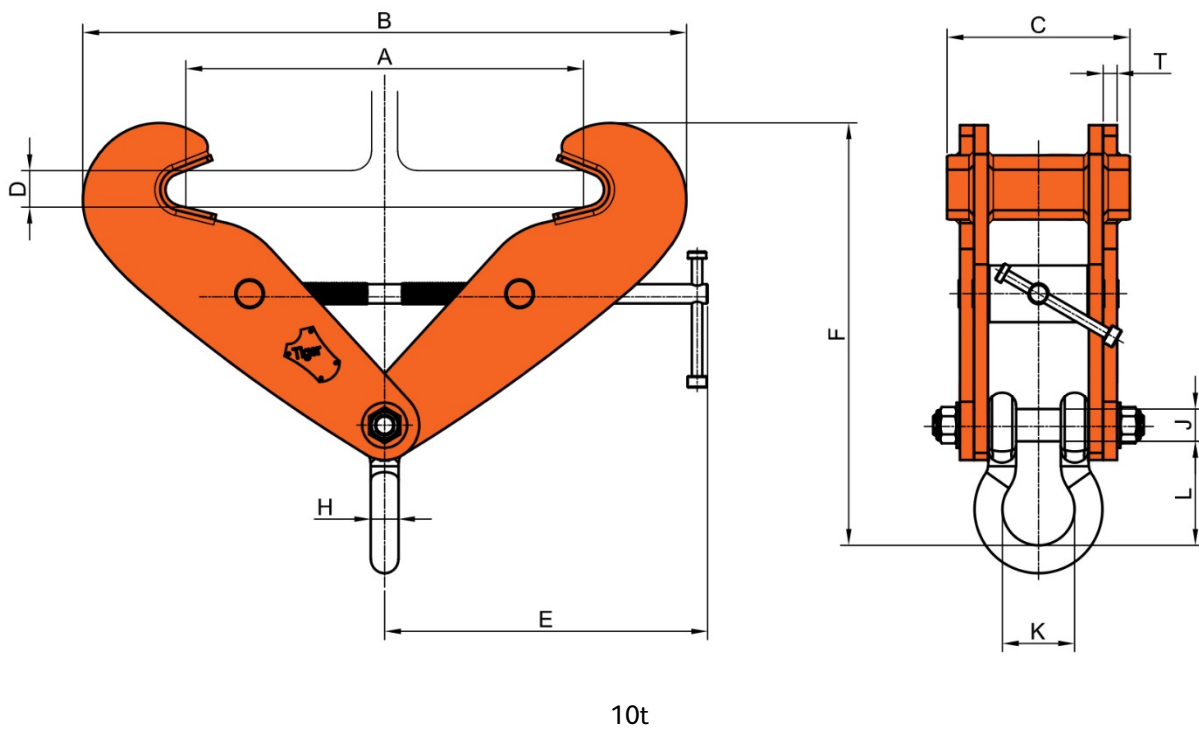
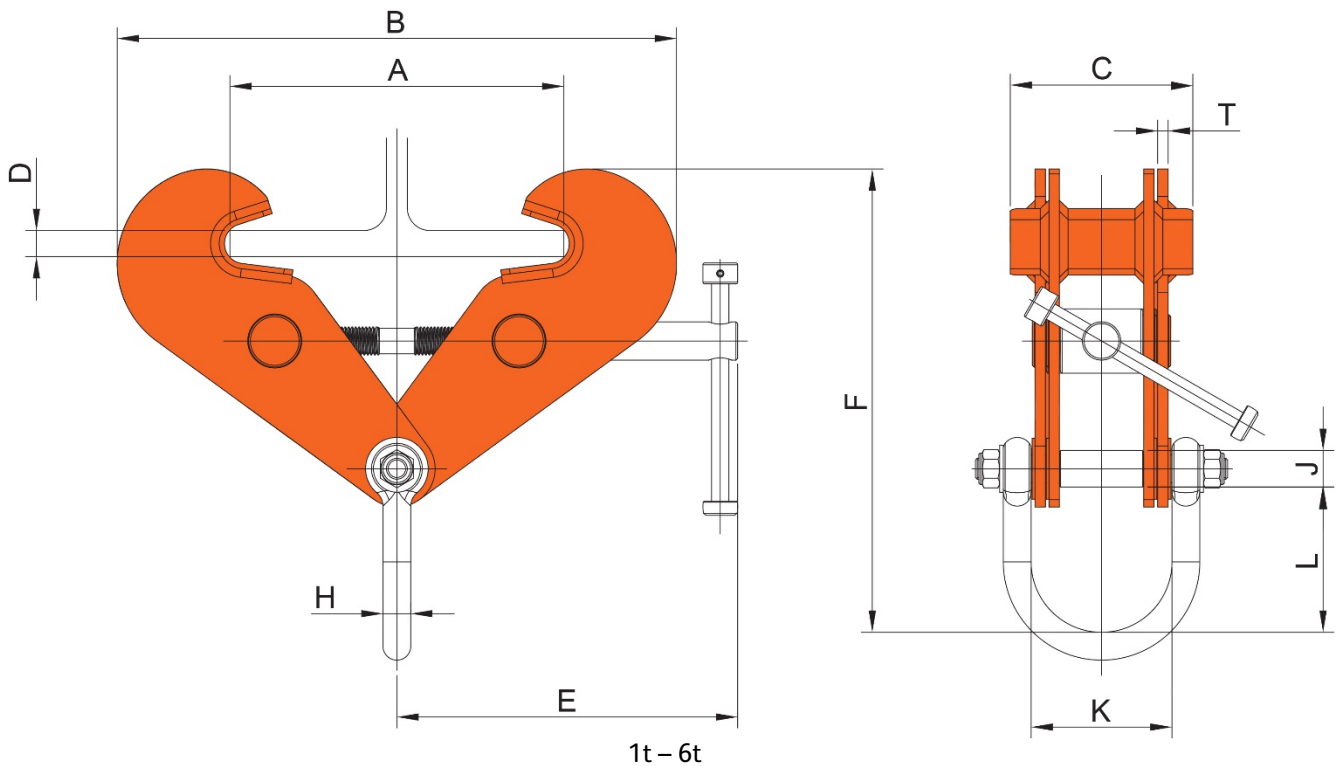

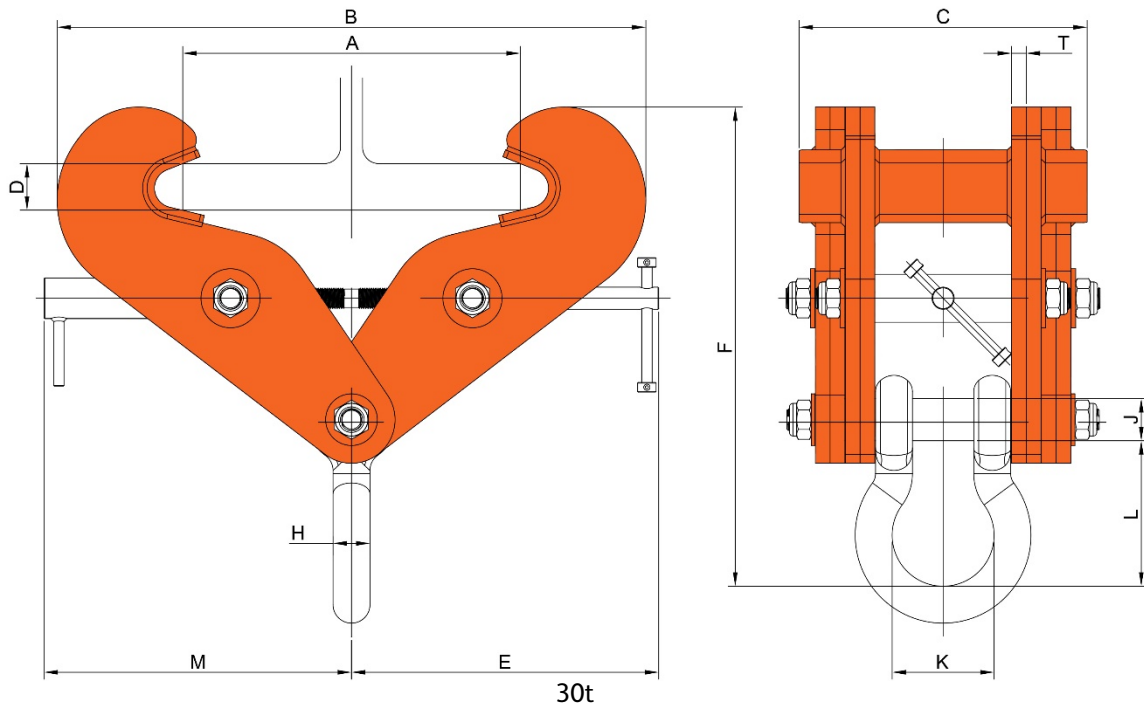
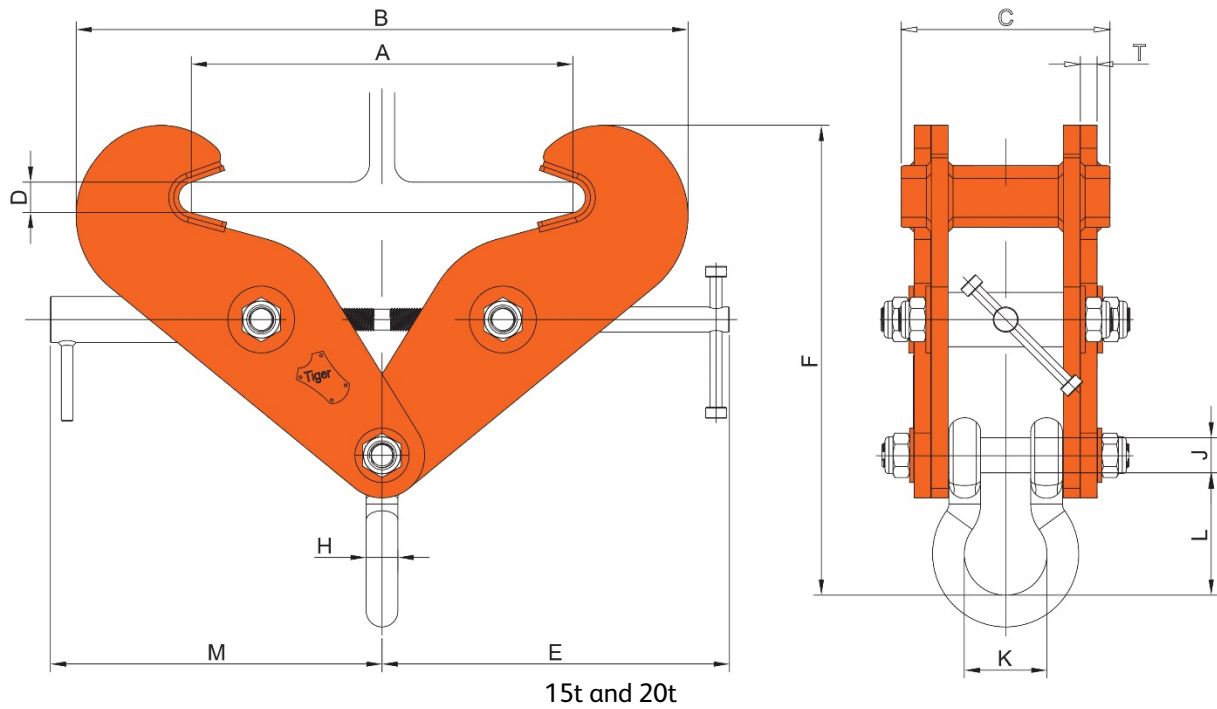

Due to our policy of continual product development, dimensions, weights and specifications may change without prior notice. Please check with your Tiger sales team when ordering.

Bespoke designs available on request – contact info@tigerlifting.com for more information.